

Wide Format Scanner

Technical Service Manual

COUGAR 25 and COUGAR 36
CHAMELEON 25 and CHAMELEON 36
CHAMELEON PREMIER 36
CHROMA Tx 40 and CRYSTAL Tx 40
COUGAR Tx 36, CHAMELEON Tx 36, and PREMIER Tx
COUGAR Sx 25 and CHAMELEON Sx 25
CHROMA XL 42 and CRYSTAL XL 42
MAGNUM XL 54

FSG/TSM/001 (2.4)

Part Number 6799D129

1

DOCUMENT REVISION RECORD

2

LIST OF DOCUMENTS

3

FSG MAINTENANCE MANUAL

COUGAR 25 and COUGAR 36
CHAMELEON 25 and CHAMELEON 36
CHAMELEON PREMIER 36
CHROMA Tx 40 and CRYSTAL Tx 40
MAGNUM XL 54
COUGAR Tx 36, CHAMELEON Tx 36, and PREMIER Tx 36

4

Addendum to FSG/MTM/001

CHROMA XL 42, CRYSTAL XL 42
COUGAR Sx 25, CHAMELEON Sx 2

5

6

7

8

9

SPARE PARTS AND SERVICE ACCESSORIES

COUGAR 25, COUGAR 36, CHAMELEON 25,
CHAMELEON 36, CHAMELEON PREMIER 36
CHROMA Tx 40, CRYSTAL Tx 40
COUGAR Tx 36, CHAMELEON Tx 36, PREMIER Tx 36
MAGNUM XL 54
COUGAR Sx 25, CHAMELEON Sx 25

10

TECHNICAL SERVICE BULLETINS

 Document Revision Record				DRR
REV.	DATE	CHANGED BY	PAGES AFFECTED	BRIEF DESCRIPTION OF CHANGE
1.0	010919	BN/LM	All	Original issue of document
1.0a	010927	LM	FSG/MTM/001	p.67, Fig. 4-8 corrected
2.0	020808	BN/LM	All	CHAMELEON PREMIER 36 CHROMA Tx 40, CRYSTAL Tx 40 added
2.0a	021030	LM	FSG/MTM/001	p.72, Fig. 4-10 updated
2.1	030507	BN/LM	All	COUGAR Tx 36, CHAMELEON Tx 36, PREMIER Tx 36 added
2.2	031031	BN/LM	All	MAGNUM XL 54 added
2.2a	040107	LM	p.4 FSG/MTM/001	List of Documents updated rev. 2.0 to 2.0a
2.2b	040427	LM	FSG/TSB/001 p.4 FSG/MTM/001	Added List of Documents updated rev. 2.0a to 2.0b
2.3	040706	LM	FSG/TSB/002 FSG/MTM/002 SOG/PLS/013	Added Added (Addendum with Sx 25 and XL 42) New spare part list (Sx 25 and XL 42 added)
2.3a	050614	LM	FSG/TSB/003	Added
2.4	060511	LM	All	FSG/MTM/001 (2.3) FSG/MTM/002 (1.1) SOG/PLS/013 (1.8) FSG/TSB/004 added

List of Documents:

FSG/MTM/001 (2.3)	FSG Maintenance Manual COUGAR 25 and COUGAR 36 CHAMELEON 25 and CHAMELEON 36 CHAMELEON PREMIER 36 CHROMA Tx 40 and CRYSTAL Tx 40 MAGNUM XL 54 COUGAR Tx 36, CHAMELEON Tx 36, and PREMIER Tx 36
FSG/MTM/002 (1.1)	Addendum to FSG/MTM/001 CHROMA XL 42, CRYSTAL XL 42 COUGAR Sx 25, CHAMELEON Sx 2
SOG/PLS/013 (1.8)	Spare Part and Service Accessories COUGAR 25, COUGAR 36, CHAMELEON 25, CHAMELEON 36, CHAMELEON PREMIER 36 CHROMA Tx 40, CRYSTAL Tx 40 COUGAR Tx 36, CHAMELEON Tx 36, PREMIER Tx 36 MAGNUM XL 54 COUGAR Sx 25, CHAMELEON Sx 25
FSG/TSB/001 (1.0)	Camera Alignment (Camera Motor Drive Belt)
FSG/TSB/002 (1.0)	Lamp Driver Adjustment
FSG/TSB/003 (1.0)	ATAC Calibration on XL 42
FSG/TSB/004 (1.0)	Camera Spare Part Board 6735D001R01

TITLE: FSG MAINTENANCE MANUAL
COUGAR 25 and COUGAR 36
CHAMELEON 25 and CHAMELEON 36
CHAMELEON PREMIER 36
CHROMA Tx 40 and CRYSTAL Tx 40
MAGNUM XL 54
COUGAR Tx 36, CHAMELEON Tx 36, and PREMIER Tx 36

DOC. NO.: FSG/MTM/001

PREPARED BY: BN/LM

AUTHORIZED: JR

DISTRIBUTION: Tegningsarkiv, Svendborg (1)
PT, Svendborg (1)
DD (1)

ISSUE REVISION: 2.3
DATE: 2006-05-11

This document is the property of Contex A/S. The data contained herein, in whole or in part, may not be duplicated, used or disclosed outside the Recipient for any purpose other than to conduct technical evaluation. This restriction does not limit the Recipients right to use information contained in the data if it is obtained from another source without restriction.

 Document Revision Record				DRR
REV.	DATE	CHANGED BY	PAGES AFFECTED	BRIEF DESCRIPTION OF CHANGE
1.0	010919 010927	BN/LM LM	All p. 67	Original issue of document Fig. 4-8 corrected
2.0	020808	BN/LM	All	CHAMELEON PREMIER 36 CHROMA Tx 40, CRYSTAL Tx 40 added Manual restructured.
2.1	030507	BN/LM	All	COUGAR Tx 36, CHAMELEON Tx 36, PREMIER Tx 36 added
2.2	031031	BN/LM	All	MAGNUM XL 54 added
2.2a	040107	LM	p.31 p.33	1st line: TP4/TP5 to TP7 and P1/P2 to P2 Fig. 3-3: Voltages for TP3/4/5 added
2.2b	040427	LM	p.29	Fig. 3.1, CN2, pin2: -12V til +12V Lamp Driver adjustment changed
2.3	060511	LM	p.30-32 All	Fig. 3-2, LME: J10 pin 5: Tolerances corrected 3.4.3: Added that LED3 might be off when lamp has been replaced Fig. 3-4, CBE: C32, right: Tolerances corrected Fig. 3-14, SKD: SW1 and SW8 interchanged 3.16, Adj. of Original Sensors: Description updated 54" Scan-Width (page 99) corrected New error codes added (70-219, 70-221, 08-220, 10-159 Replacing Guide Plate Gas Spring added Description of Test 30 added

Table of Contents

1.	Introduction.....	10
2.	General Description.....	11
2.1	COUGAR 25 AND CHAMELEON 25.....	11
2.2	COUGAR 36, CHAMELEON 36 AND CHAMELEON PREMIER 36.....	12
2.2.1	<i>COUGAR 36 and CHAMELEON 36.....</i>	<i>12</i>
2.2.2	<i>CHAMELEON PREMIER 36.....</i>	<i>13</i>
2.3	CHROMA Tx 40 AND CRYSTAL Tx 40.....	13
2.4	MAGNUM XL 54.....	15
2.5	COUGAR Tx 36, CHAMELEON Tx 36, PREMIER Tx 36.....	16
3.	Electrical Check and Adjustments.....	25
3.1	MARKING CODES FOR CIRCUIT BOARDS AND PROGRAMMED DEVICES.....	25
3.2	DOWNLOADING SCANNER FIRMWARE.....	26
3.2.1	<i>Erase and Restore Parameter Blocks.....</i>	<i>26</i>
3.3	CHECK AND ADJUSTMENT OF THE SWITCH MODE POWER SUPPLY, SMPS.....	27
3.3.1	<i>AC Voltages.....</i>	<i>27</i>
3.3.2	<i>DC Voltages.....</i>	<i>27</i>
3.3.3	<i>Adjustments.....</i>	<i>27</i>
3.3.4	<i>Fuses.....</i>	<i>27</i>
3.3.5	<i>Markings.....</i>	<i>27</i>
3.3.6	<i>Jumper Settings.....</i>	<i>27</i>
3.3.7	<i>Hints.....</i>	<i>28</i>
3.4	CHECK AND ADJUSTMENT OF LAMP AND MOTOR DRIVER BOARD, LME.....	30
3.4.1	<i>DC Voltages.....</i>	<i>30</i>
3.4.2	<i>Lamp-Driver Adjustment.....</i>	<i>30</i>
3.4.3	<i>Signal LEDs on the LME-Board.....</i>	<i>31</i>
3.4.4	<i>Stepper Motor Reference Voltages.....</i>	<i>31</i>
3.4.5	<i>Functional Test.....</i>	<i>31</i>
3.4.6	<i>Fuses.....</i>	<i>32</i>
3.4.7	<i>Markings.....</i>	<i>32</i>
3.4.8	<i>Jumper Settings.....</i>	<i>32</i>
3.4.9	<i>Hints.....</i>	<i>32</i>
3.5	CHECK AND ADJUSTMENT OF CAMERA BOARD, CBE (NON Tx AND XL MODELS).....	35
3.5.1	<i>DC Voltages.....</i>	<i>35</i>
3.5.2	<i>Adjustments.....</i>	<i>35</i>
3.5.3	<i>Functional Test.....</i>	<i>35</i>
3.5.4	<i>Markings.....</i>	<i>35</i>
3.5.5	<i>Jumper Settings.....</i>	<i>35</i>
3.5.6	<i>Hints.....</i>	<i>35</i>
3.6	CHECK AND ADJUSTMENT OF CAMERA BOARD, CBF (Tx AND XL MODELS).....	39
3.6.1	<i>DC Voltages.....</i>	<i>39</i>
3.6.2	<i>Adjustments.....</i>	<i>39</i>
3.6.3	<i>Functional Test.....</i>	<i>39</i>
3.6.4	<i>Markings.....</i>	<i>39</i>
3.6.5	<i>Jumper Settings.....</i>	<i>39</i>
3.6.6	<i>Hints.....</i>	<i>39</i>
3.7	CHECK OF CONTROLLER BOARD, SUC.....	43
3.7.1	<i>DC Voltages.....</i>	<i>43</i>
3.7.2	<i>Adjustments.....</i>	<i>43</i>
3.7.3	<i>Functional Test.....</i>	<i>43</i>
3.7.4	<i>Markings.....</i>	<i>43</i>
3.7.5	<i>Switch Settings (Download Control Switches).....</i>	<i>43</i>
3.7.6	<i>Jumper Settings.....</i>	<i>44</i>
3.7.7	<i>Signal LEDs on the SUC-Board.....</i>	<i>44</i>
3.7.8	<i>Hints.....</i>	<i>44</i>
3.8	CHECK OF INTERFACE MODULE, IMB (NON Tx AND XL MODELS).....	47

3.8.1	<i>DC Voltages</i>	47
3.8.2	<i>Adjustments</i>	47
3.8.3	<i>Functional Test</i>	47
3.8.4	<i>Markings</i>	47
3.8.5	<i>Jumper Settings</i>	47
3.8.6	<i>Hints</i>	48
3.9	CHECK OF INTERFACE MODULE, IMD (TX AND XL MODELS).....	51
3.9.1	<i>DC Voltages</i>	51
3.9.2	<i>Adjustments</i>	51
3.9.3	<i>Functional Test</i>	51
3.9.4	<i>Markings</i>	51
3.9.5	<i>Jumper Settings</i>	51
3.9.6	<i>Hints</i>	51
3.10	CHECK OF OPERATOR PANEL, SKD	54
3.10.1	<i>DC Voltages</i>	54
3.10.2	<i>Functional Test</i>	54
3.10.3	<i>Markings</i>	54
3.10.4	<i>Switch Setting (Scanner ID)</i>	54
3.11	CHECK OF SMART CARD READER, SCR	60
3.11.1	<i>DC Voltages</i>	60
3.11.2	<i>Functional Test</i>	60
3.11.3	<i>Markings</i>	60
3.11.4	<i>DIP Switch Setting</i>	60
3.11.5	<i>Signal LED on the SCR-Board</i>	61
3.12	CHECK OF LAMP SENSOR BOARD, OSB	64
3.12.1	<i>Functional Test</i>	64
3.12.2	<i>Markings</i>	64
3.13	CHECK OF OPTOINTERRUPTER BOARD, OIBA	64
3.13.1	<i>Functional Test</i>	64
3.13.2	<i>Markings</i>	64
3.14	CHECK OF ATAC MOTOR DRIVER BOARD, MDA	66
3.14.1	<i>DC Voltages</i>	66
3.14.2	<i>Adjustments</i>	66
3.14.3	<i>Functional Test</i>	66
3.14.4	<i>Markings</i>	66
3.14.5	<i>Jumper Settings</i>	66
3.14.6	<i>Hints</i>	66
3.15	CHECK AND ADJUSTMENT OF ORIGINAL GUIDE SENSORS (ATAC)	69
3.15.1	<i>Adjustment of Roller Sensor</i>	69
3.15.2	<i>Adjustment of Top Position Sensor</i>	69
3.15.3	<i>Check of ATAC Position Sensors</i>	70
3.16	ADJUSTMENT OF ORIGINAL SENSORS	76
3.16.1	<i>Adjustment of Switch Point</i>	76
3.16.2	<i>Functional Test</i>	76
3.16.3	<i>Hints</i>	76
3.17	CHECK OF MEDIA THICKNESS DETECTOR (NOT APPLICABLE TO MAGNUM XL 54).....	78
3.17.1	<i>Functional Test</i>	78
4.	CCD-Cameras	79
4.1	DESCRIPTION OF CCD-CAMERAS	79
4.2	CCD-CAMERA CHECK AND ADJUSTMENT	86
4.2.1	<i>Check of Light Profiles</i>	87
4.2.2	<i>Hints</i>	88
4.2.3	<i>Camera Adjustment Wizard</i>	94
4.2.4	<i>Check and Adjustment of Focus</i>	94
4.2.5	<i>Check and Adjustment of Scan-Width</i>	99
4.2.6	<i>Check and Adjustment of CCD-Centering</i>	109
4.2.7	<i>Check and Adjustment of Vertical Positioning</i>	110
4.2.8	<i>Final Check</i>	113

5.	Vertical Alignment and Horizontal Stitching.....	130
5.1	PRINCIPLE OF STITCHING	130
5.2	VERTICAL ALIGNMENT AND HORIZONTAL STITCHING PROCEDURE.....	133
6.	General Maintenance.....	141
6.1	STEP BY STEP PROCEDURE FOR GENERAL MAINTENANCE	141
6.1.1	<i>Remove Top Cover</i>	141
6.1.2	<i>Cleaning of the Scanning Area</i>	141
6.1.3	<i>Fluorescent Lamp</i>	141
6.1.4	<i>Check Lamp Driver Adjustment</i>	141
6.1.5	<i>Check CCD-Camera Adjustment</i>	142
6.1.6	<i>Replace Top Cover</i>	142
6.1.7	<i>Run Scanner Maintenance</i>	142
7.	Troubleshooting	146
7.1	POWER-ON SELF-TEST	146
7.2	LED INDICATORS ON OPERATOR PANEL.....	147
7.3	ERROR CODES.....	147
7.3.1	<i>Error Codes displayed on the Operator Panel</i>	147
7.3.2	<i>Error Codes displayed on the PC Screen</i>	148
7.4	TROUBLESHOOTING HINTS.....	152
8.	Disassembly and Assembly.....	156
8.1	TOP COVER WITH FRONT PROFILE	156
8.2	END COVERS.....	156
8.3	REAR COVER	156
8.4	BOTTOM PLATE.....	156
8.5	TOP PROFILE (LID).....	157
8.6	ORIGINAL GUIDE PLATE WITH ATAC.....	157
8.7	GLASS PLATE.....	157
8.8	ENTRY ROLLER SHIELD	157
8.9	EXIT ROLLER SHIELD.....	158
8.10	MIRROR CHASSIS	159
8.11	REFLECTOR ASSEMBLY.....	159
9.	Replacement of Parts.....	161
9.1	FEED ROLLER SHAFT	161
9.2	ORIGINAL SENSOR ACTUATORS.....	162
9.3	STITCHING WIRE.....	162
9.4	FLUORESCENT LAMP	162
9.5	STEPPER MOTOR	163
9.6	CAMERA MOTOR	163
9.7	CAMERA BOARD, CBE/CBF	164
9.8	LAMP SENSOR BOARD, OSB	164
9.9	INTERFACE BOARDS, IMB AND IMD	165
9.10	DUST FILTER ON FAN.....	165
9.11	WHITE BACKGROUND PLATE.....	165
9.12	SLIDER FOR MEDIA THICKNESS ADJUSTMENT	166
9.13	ELEVATION MOTOR (ATAC).....	166
9.14	ORIGINAL GUIDE SENSORS (ATAC).....	166
9.15	GAS SPRING FOR GUIDE PLATE.....	167
10.	SCANtest 6.....	171
10.1	DESCRIPTION OF SCANTEST 6.....	172
10.1.1	<i>Test 1, Scanner Information</i>	172
10.1.2	<i>Test 2, LED Test</i>	172
10.1.3	<i>Test 3, Key Test</i>	172
10.1.4	<i>Test 4, Original-Sensor Test</i>	172
10.1.5	<i>Test 5, Lamp Test</i>	173
10.1.6	<i>Test 6, Motor Test</i>	173
10.1.7	<i>Test 7, Complete Hardware Test</i>	173
10.1.8	<i>Test 9, Camera Adjustment</i>	173

- 10.1.9 Test 11, *Stitching and Vertical Alignment*..... 173
- 10.1.10 Test 12, *Adjustment of Y-Axis Scaling*..... 174
- 10.1.11 Test 13, *Switch Scanner to Test Mode*..... 174
- 10.1.12 Test 20, *Noise Test* 174
- 10.1.13 Test 21, *SCANdump* 177
- 10.1.14 Test 27, *Camera Adjustment Wizard*..... 177
- 10.1.15 Test 28, *Original Guide Sensor Test* 177
- 10.1.16 Test 30, *Calibrate ATAC* 177

- 11. Wiring Diagrams**..... **178**

- 12. Special Service Tools**..... **193**

List of Figures

Fig. 2-1	COUGAR 25 Block Diagram.....	18
Fig. 2-2	CHAMELEON 25 Block Diagram.....	19
Fig. 2-3	COUGAR 36 Block Diagram.....	20
Fig. 2-4	CHAMELEON 36 and CHAMELEON PREMIER 36 Block Diagram.....	21
Fig. 2-5	CHROMA Tx 40 and CRYSTAL Tx 40 Block Diagram.....	22
Fig. 2-6	MAGNUM XL 54 Block Diagram.....	23
Fig. 2-7	COUGAR Tx 36, CHAMELEON Tx 36 and PREMIER Tx 36 Block Diagram.....	24
Fig. 3-1	SMPS Test Points	29
Fig. 3-2	LME Component Layout.....	33
Fig. 3-3	LME Block Diagram	34
Fig. 3-4	CBE Component Layout.....	37
Fig. 3-5	CBE Block Diagram	38
Fig. 3-6	CBF Component Layout.....	41
Fig. 3-7	CBF Block Diagram	42
Fig. 3-8	SUC Component Layout.....	45
Fig. 3-9	SUC Block Diagram	46
Fig. 3-10	IMB Component Layout.....	49
Fig. 3-11	IMB Block Diagram	50
Fig. 3-12	IMD Component Layout.....	52
Fig. 3-13	IMD Block Diagram	53
Fig. 3-14	SKDA Component Layout	56
Fig. 3-15	SKDA Block Diagram.....	57
Fig. 3-16	SKDF Component Layout	58
Fig. 3-17	SKDF Block Diagram.....	59
Fig. 3-18	SCR Component Layout.....	62
Fig. 3-19	SCR Block Diagram	63
Fig. 3-20	OSB Component Layout.....	65
Fig. 3-21	OIBA Component Layout.....	65
Fig. 3-22	MDA Component Layout.....	67
Fig. 3-23	MDA Block Diagram	68
Fig. 3-24	Adjustment of Roller Sensor	72
Fig. 3-25	Adjustment of Top Position Sensor	73
Fig. 3-26	Elevation Motor and Spindle.....	74
Fig. 3-27	Adjustment Tool for Roller Sensor.....	75
Fig. 3-28	Adjustment Tool for Top Position Sensors	75
Fig. 3-29	Adjustment of Original-Sensors	77
Fig. 4-1	Focus Lock Mechanism.....	82
Fig. 4-2	CCD-Camera, Side View.....	83
Fig. 4-3	CCD-Camera, Top View	84
Fig. 4-4	Relations between Optical Adjustment Pattern and Screen Images	85
Fig. 4-5	COUGAR 25, CHAMELEON 25, Light Profiles Uncorrected.....	89
Fig. 4-6	COUGAR 25, CHAMELEON 25, Light Profiles Corrected.....	89
Fig. 4-7	COUGAR 36, CHAMELEON 36, PREMIER 36, Light Profiles Uncorrected	90
Fig. 4-8	COUGAR 36, CHAMELEON 36, PREMIER 36, Light Profiles Corrected	90
Fig. 4-9	CHROMA Tx 40, CRYSTAL Tx 40, Light Profiles Uncorrected.....	91
Fig. 4-10	CHROMA Tx 40, CRYSTAL Tx 40, Light Profiles Corrected.....	91
Fig. 4-11	MAGNUM XL 54, Light Profiles Uncorrected.....	92
Fig. 4-12	MAGNUM XL 54, Light Profiles Corrected.....	92
Fig. 4-13	COUGAR Tx 36, CHAMELEON Tx 36, PREMIER Tx 36, Light Profiles Uncorrected	93
Fig. 4-14	COUGAR Tx 36, CHAMELEON Tx 36, PREMIER Tx 36, Light Profiles Corrected	93
Fig. 4-15	COUGAR 25, CHAMELEON 25, Focus Signals	96
Fig. 4-16	COUGAR 36, CHAMELEON 36, PREMIER 36, Focus Signals.....	96
Fig. 4-17	CHROMA Tx 40, CRYSTAL Tx 40, Focus Signals	97
Fig. 4-18	MAGNUM XL 54, Focus Signals.....	97

Fig. 4-19	COUGAR Tx 36, CHAMELEON Tx 36, PREMIER Tx 36, Focus Signals.....	98
Fig. 4-20	COUGAR 25, CHAMELEON 25, Scan-Width	102
Fig. 4-21	COUGAR 36, CHAMELEON 36, PREMIER 36, Scan-Width (A).....	103
Fig. 4-22	COUGAR 36, CHAMELEON 36, PREMIER 36, Scan-Width (B).....	103
Fig. 4-23	CHROMA Tx 40, CRYSTAL Tx 40, Scan-Width (A)	104
Fig. 4-24	CHROMA Tx 40, CRYSTAL Tx 40, Scan-Width (B)	104
Fig. 4-25	CHROMA Tx 40, CRYSTAL Tx 40, Scan-Width (C)	105
Fig. 4-26	MAGNUM XL 54, Scan-Width (A).....	106
Fig. 4-27	MAGNUM XL 54, Scan-Width (B).....	106
Fig. 4-28	MAGNUM XL 54, Scan-Width (C).....	107
Fig. 4-29	MAGNUM XL 54, Scan-Width (D).....	107
Fig. 4-30	COUGAR Tx 36, CHAMELEON Tx 36, PREMIER Tx 36, Scan-Width (A)	108
Fig. 4-31	COUGAR Tx 36, CHAMELEON Tx 36, PREMIER Tx 36, Scan-Width (B)	108
Fig. 4-32	COUGAR 25, CHAMELEON 25, CCD-Centering and Vertical Positioning	114
Fig. 4-33	COUGAR 36, CHAMELEON 36, PREMIER 36, CCD-Centering and Vertical Positioning (A)....	115
Fig. 4-34	COUGAR 36, CHAMELEON 36, PREMIER 36, CCD-Centering and Vertical Positioning (B)....	115
Fig. 4-35	CHROMA Tx 40, CRYSTAL Tx 40, CCD-Centering and Vertical Positioning (A)	116
Fig. 4-36	CHROMA Tx 40, CRYSTAL Tx 40, CCD-Centering and Vertical Positioning (B)	116
Fig. 4-37	CHROMA Tx 40, CRYSTAL Tx 40, CCD-Centering and Vertical Positioning (C)	117
Fig. 4-38	MAGNUM XL 54, CCD-Centering and Vertical Positioning (A).....	118
Fig. 4-39	MAGNUM XL 54, CCD-Centering and Vertical Positioning (B)	118
Fig. 4-40	MAGNUM XL 54, CCD-Centering and Vertical Positioning (C).....	119
Fig. 4-41	MAGNUM XL 54, CCD-Centering and Vertical Positioning (D).....	119
Fig. 4-42	COUGAR Tx 36, CHAMELEON Tx 36, PREMIER Tx 36, CCD-Centering and Vertical Positioning (A).....	120
Fig. 4-43	COUGAR Tx 36, CHAMELEON Tx 36, PREMIER Tx 36, CCD-Centering and Vertical Positioning (B).....	120
Fig. 4-44	CCD-Camera Overview (Adjustments).....	121
Fig. 4-45	Optical Adjustment Pattern, 25"	122
Fig. 4-46	Optical Adjustment Pattern, 2 Cam., 36"	123
Fig. 4-47	Optical Adjustment Pattern, 2 Cam., 40"	124
Fig. 4-48	Optical Adjustment Pattern, 3 Cam., 40"	125
Fig. 4-49	Optical Adjustment Pattern, 4 Cam., 54"	126
Fig. 4-50	Focus Pattern, 25"	127
Fig. 4-51	Focus Pattern, 40"	128
Fig. 4-52	Focus Pattern, 54"	129
Fig. 5-1	Principle of Stitching	131
Fig. 5-2	Stitching Wire Mounting	132
Fig. 5-3	COUGAR 36, CHAMELEON 36, PREMIER 36, Stitching Images	134
Fig. 5-4	CHROMA Tx 40, CRYSTAL Tx 40, Stitching Images A/B	135
Fig. 5-5	CHROMA Tx 40, CRYSTAL Tx 40, Stitching Images B/C	136
Fig. 5-6	MAGNUM XL 54, Stitching Images A/B	137
Fig. 5-7	MAGNUM XL 54, Stitching Images B/C.....	138
Fig. 5-8	MAGNUM XL 54, Stitching Images C/D.....	139
Fig. 5-9	COUGAR Tx 36, CHAMELEON Tx 36, PREMIER Tx 36, Stitching Images	140
Fig. 6-1	SM Calibration Sheet, 25"	143
Fig. 6-2	SM Calibration Sheet, 40"	144
Fig. 6-3	SM Calibration Sheet, 54"	145
Fig. 9-1	Gas Sprin for Guide Plate	167
Fig. 9-2	Transmission.....	168
Fig. 9-3	Drive-Belt Tightener.....	169
Fig. 9-4	Scanner Cross Section	170
Fig. 10-1	Noise Test, Example	176
Fig. 11-1	COUGAR 25 Primary Wiring	179
Fig. 11-2	COUGAR 25, Secondary Wiring	180
Fig. 11-3	CHAMELEON 25, Primary Wiring	181
Fig. 11-4	CHAMELEON 25, Secondary Wiring	182
Fig. 11-5	COUGAR 36, Primary Wiring	183
Fig. 11-6	COUGAR 36, Secondary Wiring	184

Fig. 11-7 CHAMELEON 36, PREMIER 36, Primary Wiring..... 185
Fig. 11-8 CHAMELEON 36, PREMIER 36, Secondary Wiring..... 186
Fig. 11-9 CHROMA Tx 40, CRYSTAL Tx 40, Primary Wiring..... 187
Fig. 11-10 CHROMA Tx 40, CRYSTAL Tx 40, Secondary Wiring..... 188
Fig. 11-11 MAGNUM XL 54, Primary Wiring 189
Fig. 11-12 MAGNUM XL 54, Secondary Wiring 190
Fig. 11-13 COUGAR Tx 36, CHAMELEON Tx 36, PREMIER Tx 36, Primary Wiring..... 191
Fig. 11-14 COUGAR Tx 36, CHAMELEON Tx 36, PREMIER Tx 36, Secondary Wiring..... 192

1. Introduction

The purpose of this Maintenance Manual is to provide technical information to support board-level troubleshooting and maintenance of the Wide Format Scanners models:

GA67D (COUGAR 25, COUGAR 25 PLUS)
GB67D (COUGAR 36, COUGAR 36 PLUS)
GC67D (CHAMELEON 25, CHAMELEON 25 PLUS)
GD67D (CHAMELEON 36, CHAMELEON 36 PLUS)
GE67D (CHROMA Tx 40, CHROMA Tx 40 PLUS)
GF67D (CRYSTAL Tx 40, CRYSTAL Tx 40 PLUS)
GG67D (CHAMELEON PREMIER 36, CHAMELEON PREMIER 36 PLUS)
GH67D (MAGNUM XL 54)
GK67D (COUGAR Tx 36, COUGAR Tx 36 PLUS)
GL67D (CHAMELEON Tx 36, CHAMELEON Tx 36 PLUS)
GM67D (PREMIER Tx 36, PREMIER Tx 36 PLUS)

Chapter 2 contains a general technical description based on block diagrams.

Chapter 3 describes Electrical Check and Adjustments including jumper and switch settings.

Chapter 4 contains a general description of the Optical System and the CCD-Camera Adjustments.

Chapter 5 describes Stitching and Vertical Alignment.

Chapter 6 describes General Maintenance.

Chapter 7 contains a list of Error Codes and gives some hints on troubleshooting.

Chapter 8 describes Disassembly and Assembly procedures.

Chapter 9 provides a guide for replacement of parts for which the procedure is not obvious.

Chapter 10 describes the scanner test program, SCANtest 6.

Chapter 11 contains Wiring Diagrams.

Chapter 12 contains a list of Special Service Tools.

2. General Description

The Wide Format Scanners models:

- GA67D (COUGAR 25, COUGAR 25 PLUS)
- GB67D (COUGAR 36, COUGAR 36 PLUS)
- GC67D (CHAMELEON 25, CHAMELEON 25 PLUS)
- GD67D (CHAMELEON 36, CHAMELEON 36 PLUS)
- GE67D (CHROMA Tx 40)
- GF67D (CRYSTAL Tx 40)
- GG67D (CHAMELEON PREMIER 36)
- GH67D (MAGNUM XL 54)
- GK67D (COUGAR Tx 36)
- GL67D (CHAMELEON Tx 36)
- GM67D (PREMIER Tx 36)

are described at block-diagram level in Sections 2.1 through 2.5.

2.1 COUGAR 25 and CHAMELEON 25

The Block Diagrams are shown in:

Fig. 2-1 COUGAR 25 Block Diagram, page 18

Fig. 2-2 CHAMELEON 25 Block Diagram, page 19

The COUGAR 25 and CHAMELEON 25 scanner range consists of:

Model:	GA67D		GC67D	
Trade name:	COUGAR 25	COUGAR PLUS 25	CHAMELEON 25	CHAMELEON PLUS 25
No. of cameras:	1	1	1	1
Chassis:	25 inches	25 inches	25 inches	25 inches
Scan width:	25 inches	25 inches	25 inches	25 inches
Computer interface:	USB/SCSI (IMBA)	USB/SCSI (IMBA)	USB (IMBB)	USB (IMBB)
Scan mode:	Color Monochrome	Color Monochrome	Monochrome	Color Monochrome
Optical resolution:	424 dpi	424 dpi	424 dpi	424 dpi
SmartCard:	BASIC	PLUS	BASIC	PLUS

Each of the two models GA67D and GC67D are marketed with two different levels of functionality, such as image resolution, scanning speed, scanning modes, etc:

Model: GA67D (USB and SCSI interface)
 Trade names: COUGAR 25 (basic level of functionality)
 COUGAR 25 PLUS (enhanced level of functionality)

Model: GC67D (USB interface only)
 Trade names: CHAMELEON 25 (basic level of functionality)
 CHAMELEON 25 PLUS (enhanced level of functionality)

The basic versions of the scanners (COUGAR 25 and CHAMELEON 25) may be field upgraded to the enhanced versions (COUGAR 25 PLUS and CHAMELEON 25 PLUS) by replacing the BASIC Smart Card with a PLUS Smart Card.

The scan-area is illuminated by one white fluorescent lamp. The light output from the lamp is stabilized by feedback to the lamp power supply board (LME).

The CCD-Camera in the scanner contains one 10680 x 3 pixel color CCD. The output signals from the CCD are Light Profile Corrected at pixel level.

All scanning and image processing functions are contained on only two boards, the Camera Board (CBE) and the Controller Board (SUC).

The Interface Module (IMB) contains:

- USB Controller
- SCSI Controller (COUGAR only)

for USB interface respectively SCSI interface. If the computer is connected to both USB and SCSI interface, the scanner software presents a choice between the two modes to the user.

2.2 COUGAR 36, CHAMELEON 36 and CHAMELEON PREMIER 36

The Block Diagrams are shown in:

Fig. 2-3 COUGAR 36 Block Diagram, page 20

Fig. 2-4 CHAMELEON 36 and CHAMELEON PREMIER 36 Block Diagram, page 21

2.2.1 COUGAR 36 and CHAMELEON 36

The COUGAR 36 and CHAMELEON 36 scanner range consists of:

Model:	GB67D		GD67D	
Trade name:	COUGAR 36	COUGAR 36 PLUS	CHAMELEON 36	CHAMELEON 36 PLUS
No. of cameras:	2	2	2	2
Chassis:	40 inches	40 inches	40 inches	40 inches
Scan width:	36 inches	36 inches	36 inches	36 inches
Scanner Controller:	SUCA	SUCA	SUCA	SUCA
Computer interface:	USB/SCSI (IMBA)	USB/SCSI (IMBA)	USB (IMBB)	USB (IMBB)
Scan mode:	Color Monochrome	Color Monochrome	Monochrome	Color Monochrome
Optical resolution:	424 dpi	424 dpi	424 dpi	424 dpi
SmartCard:	BASIC	PLUS	BASIC	PLUS

Each of the two models GB67D and GD67D are marketed with two different levels of functionality, such as image resolution, scanning speed, scanning modes, etc:

- Model: GB67D (USB and SCSI interface)
- Trade names: COUGAR 36 (basic level of functionality)
- COUGAR 36 PLUS (enhanced level of functionality)

- Model: GD67D (USB interface only)

Trade names: CHAMELEON 36 (basic level of functionality)
 CHAMELEON 36 PLUS (enhanced level of functionality)

The basic versions of the scanners (COUGAR 36 and CHAMELEON 36) may be field upgraded to the enhanced versions (COUGAR 36 PLUS and CHAMELEON 36 PLUS) by replacing the BASIC Smart Card with a PLUS Smart Card.

The scan-area is illuminated by one white fluorescent lamp. The light output from the lamp is stabilized by feedback to the lamp power supply board (LME).

Each CCD-Camera in the scanner contains one 10680 x 3 pixel color CCD. The output signals from the CCDs are Light Profile Corrected at pixel level.

All scanning and image processing functions are contained on only two boards, the Camera Board (CBE) and the Controller Board (SUC).

The computer Interface Module (IMB) contains:

USB Controller
 SCSI Controller (COUGAR only)

for USB interface respectively SCSI interface. If the computer is connected to both USB and SCSI interface, the scanner software presents a choice between the two modes to the user.

In order to stitch (bring together) the scanlines from adjacent cameras, the fields of vision of the CCD-Cameras overlap slightly and a thin, black wire placed within the overlapped fields of vision marks the virtual end, respectively start, of adjacent scanlines.

The scanlines from the individual cameras are mechanically aligned (by means of a small electric motor) in the vertical direction. The Vertical Alignment and the Horizontal Stitching may be done automatically by means of either SCANtest 6, Test 11 or as part the Scanner Maintenance calibration procedure.

2.2.2 CHAMELEON PREMIER 36

The CHAMELEON PREMIER 36 is an all monochrome scanner and can not be upgraded to include color mode.

Model: GG67D (USB interface only)
 Trade names: CHAMELEON PREMIER 36 (basic level of functionality)
 CHAMELEON PREMIER 36 PLUS (enhanced level of functionality)

Except for the Scanner Controller Board (SUCD) and Scanner ID Switch setting, CHAMELEON PREMIER 36 is electrically and mechanically identical to CHAMELEON 36.

2.3 CHROMA Tx 40 and CRYSTAL Tx 40

The Block Diagram is shown in:

Fig. 2-5 CHROMA Tx 40 and CRYSTAL Tx 40 Block Diagram, page 22

The Tx 40 scanner range consists of:

Model:	GE67D		GF67D	
Trade name:	CHROMA Tx 40	CHROMA Tx 40 PLUS	CRYSTAL Tx 40	CRYSTAL Tx 40 PLUS
No. of cameras:	3	3	3	3
Chassis:	40 inches	40 inches	40 inches	40 inches
Scan width:	40 inches	40 inches	40 inches	40 inches
Scanner Controller:	SUCB	SUCB	SUCC	SUCC
Computer interface:	IEEE 1394/SCSI (IMDA)	IEEE 1394/SCSI (IMDA)	IEEE 1394/SCSI (IMDA)	IEEE 1394/SCSI (IMDA)
Scan mode:	Color Monochrome	Color Monochrome	Color Monochrome	Color Monochrome
Optical resolution:	508 dpi	508 dpi	508 dpi	508 dpi
SmartCard:	BASIC	PLUS	BASIC	PLUS

Each of the two models GE67D and GF67D are marketed with two different levels of functionality, such as image resolution, scanning speed, scanning modes, etc:

Model: GE67D (IEEE 1394 and SCSI interface)
 Trade names: CHROMA Tx 40 (basic level of functionality)
 CHROMA Tx 40 PLUS (enhanced level of functionality)

Model: GF67D (IEEE 1394 and SCSI interface)
 Trade names: CRYSTAL Tx 40 (basic level of functionality)
 CRYSTAL Tx 40 PLUS (enhanced level of functionality)

The basic versions of the scanners (CHROMA Tx 40 and CRYSTAL Tx 40) may be field upgraded to the enhanced versions (CHROMA Tx 40 PLUS and CRYSTAL Tx 40 PLUS) by replacing the BASIC Smart Card with a PLUS Smart Card.

The scan-area is illuminated by one white fluorescent lamp. The light output from the lamp is stabilized by feedback to the lamp power supply board (LME).

Each CCD-Camera in the scanner contains one 7500 x (3+1) pixel (RGB Triplets + Panchromatic B/W) CCD. The output signals from the CCDs are Light Profile Corrected at pixel level.

All scanning and image processing functions are contained on only two boards, the Camera Board (CBF) and the Controller Board (SUC).

The computer Interface Module (IMD) contains:

IEEE 1394 Controller (FireWire)
 SCSI Controller

for IEEE 1394 interface respectively SCSI interface.

In order to stitch (bring together) the scanlines from adjacent cameras, the fields of vision of the CCD-Cameras overlap slightly and a thin, black wire placed within the overlapped fields of vision marks the virtual end, respectively start, of adjacent scanlines.

The scanlines from the individual cameras are mechanically aligned (by means of a small electric motor) in the vertical direction. The Vertical Alignment and the Horizontal Stitching may be done automatically by means of either SCANtest 6, Test 11 or as part the Scanner Maintenance calibration procedure.

2.4 MAGNUM XL 54

The Block Diagram is shown in:

Fig. 2-6 MAGNUM XL 54 Block Diagram, page 23

The XL 54 scanner range consists of:

Model:	GH67D	
Trade name:	MAGNUM XL 54	MAGNUM XL 54 PLUS
No. of cameras:	4	4
Chassis:	54 inches	54 inches
Scan width:	54 inches	54 inches
Scanner Controller:	SUCH	SUCH
Computer interface:	IEEE 1394/SCSI (IMDA)	IEEE 1394/SCSI (IMDA)
Scan mode:	Color Monochrome	Color Monochrome
Optical resolution:	508 dpi	508 dpi
SmartCard:	BASIC	PLUS

Model GH67D is marketed with two different levels of functionality, such as image resolution, scanning speed, scanning modes, etc:

Model:	GH67D	(IEEE 1394 and SCSI interface)
Trade names:	MAGNUM XL 54	(basic level of functionality)
	MAGNUM XL 54 PLUS	(enhanced level of functionality)

The basic version of the scanner (MAGNUM XL 54) may be field upgraded to the enhanced version (MAGNUM XL 54 PLUS) by replacing the BASIC Smart Card with a PLUS Smart Card.

The Automatic Thickness Adjustment Control (ATAC) automatically adjusts for media thickness up to 0.6 inch (15 mm). The motor driver board (MDA) and the motor for the ATAC system are located in a non-removeable Original Guide Plate.

The scan-area is illuminated by one white fluorescent lamp. The light output from the lamp is stabilized by feedback to the lamp power supply board (LME).

Each CCD-Camera in the scanner contains one 7500 x (3+1) pixel (RGB Triplets + Panchromatic B/W) CCD. The output signals from the CCDs are Light Profile Corrected at pixel level.

All scanning and image processing functions are contained on only two boards, the Camera Board (CBF) and the Controller Board (SUC).

The computer Interface Module (IMD) contains:

IEEE 1394 Controller (FireWire)
SCSI Controller

for IEEE 1394 interface respectively SCSI interface.

In order to stitch (bring together) the scanlines from adjacent cameras, the fields of vision of the CCD-Cameras overlap slightly and a thin, black wire placed within the overlapped fields of vision marks the virtual end, respectively start, of adjacent scanlines.

The scanlines from the individual cameras are mechanically aligned (by means of a small electric motor) in the vertical direction. The Vertical Alignment and the Horizontal Stitching may be done automatically by means of either SCANtest 6, Test 11 or as part the Scanner Maintenance calibration procedure.

2.5 COUGAR Tx 36, CHAMELEON Tx 36, PREMIER Tx 36

The Block Diagram is shown in:

Fig. 2-7 COUGAR Tx 36, CHAMELEON Tx 36 and PREMIER Tx 36 Block Diagram, page 24

The Tx 36 scanner range consists of:

Model:	GK67D	GL67D	GM67D
Trade name:	COUGAR Tx 36	CHAMELEON Tx 36	PREMIER Tx 36
No. of cameras:	2	2	2
Chassis:	40 inches	40 inches	40 inches
Scan width:	36 inches	36 inches	36 inches
Scanner Controller:	SUCB	SUCC	SUCG
Computer interface:	IEEE 1394/SCSI (IMDA)	IEEE 1394/SCSI (IMDA)	IEEE 1394/SCSI (IMDA)
Scan mode:	Color Monochrome	Color Monochrome	Monochrome
Optical resolution:	400 dpi	400 dpi	400 dpi

Each of the three models GK67D, GL67D, and GM67D are marketed with two different levels of functionality, such as image resolution, scanning speed, scanning modes, etc:

Model: GK67D (IEEE 1394 and SCSI interface)
Trade names: COUGAR Tx 36 (basic level of functionality)
COUGAR Tx 36 PLUS (enhanced level of functionality)

Model: GL67D (IEEE 1394 and SCSI interface)
Trade names: CHAMELEON Tx 36 (basic level of functionality)
CHAMELEON Tx 36 PLUS (enhanced level of functionality)

Model: GM67D (IEEE 1394 and SCSI interface)
Trade names: PREMIER Tx 36 (basic level of functionality)
PREMIER Tx 36 PLUS (enhanced level of functionality)

The basic versions of the scanners (COUGAR Tx 36, CHAMELEON Tx 36, and PREMIER Tx 36) may be field upgraded to the enhanced versions (COUGAR Tx 36 PLUS,

CHAMELEON Tx 36 PLUS, and PREMIER Tx 36 PLUS) by replacing the BASIC Smart Card with a PLUS Smart Card.

The scan-area is illuminated by one white fluorescent lamp. The light output from the lamp is stabilized by feedback to the lamp power supply board (LME).

Each CCD-Camera in the scanner contains one 7500 x (3+1) pixel (RGB Triplets + Panchromatic B/W) CCD. The output signals from the CCDs are Light Profile Corrected at pixel level.

All scanning and image processing functions are contained on only two boards, the Camera Board (CBF) and the Controller Board (SUC).

The computer Interface Module (IMD) contains:

IEEE 1394 Controller (FireWire)
SCSI Controller

for IEEE 1394 interface respectively SCSI interface.

In order to stitch (bring together) the scanlines from adjacent cameras, the fields of vision of the CCD-Cameras overlap slightly and a thin, black wire placed within the overlapped fields of vision marks the virtual end, respectively start, of adjacent scanlines.

The scanlines from the individual cameras are mechanically aligned (by means of a small electric motor) in the vertical direction. The Vertical Alignment and the Horizontal Stitching may be done automatically by means of either SCANtest 6, Test 11 or as part the Scanner Maintenance calibration procedure.

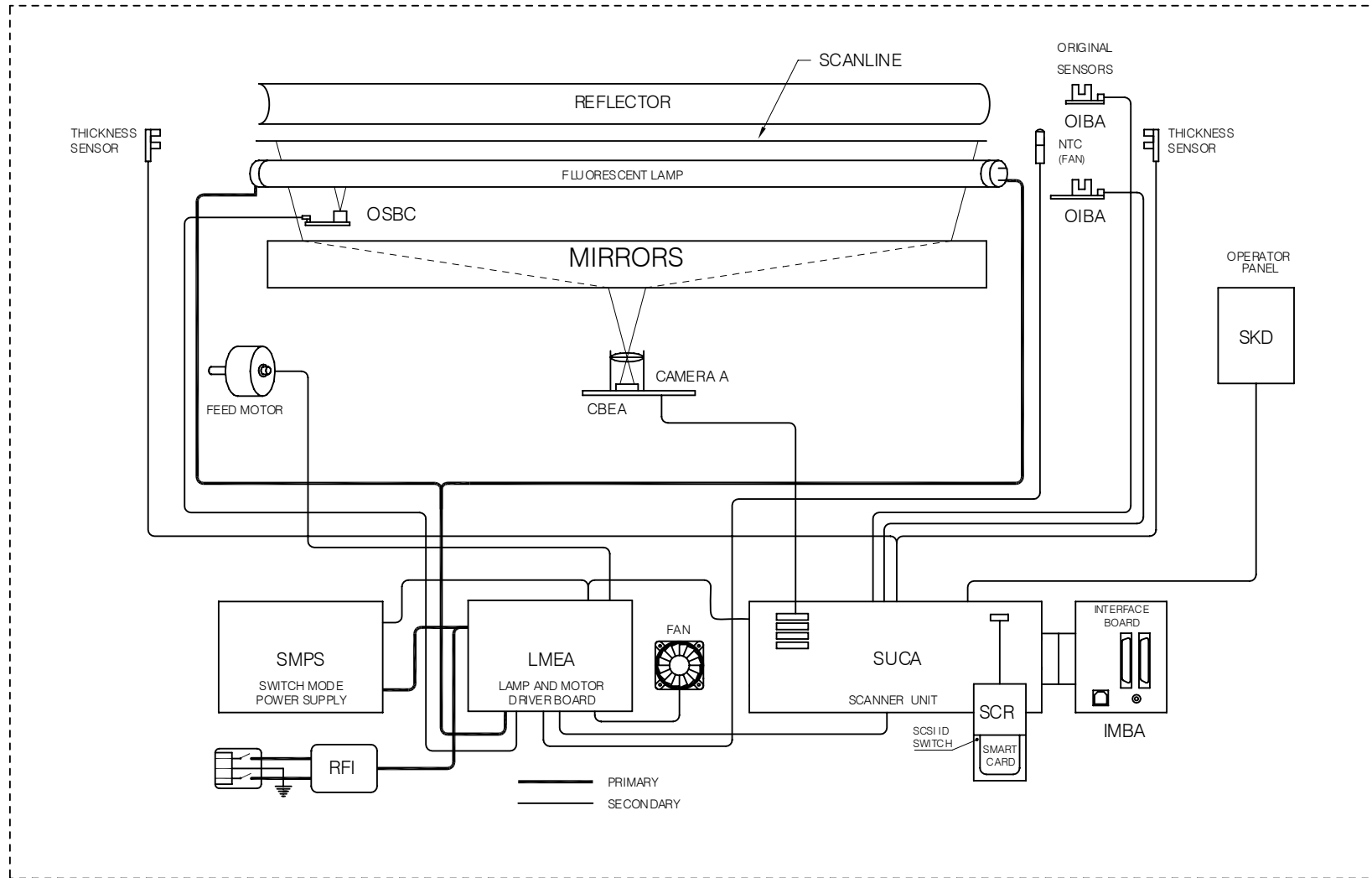

Fig. 2-1 COUGAR 25 Block Diagram

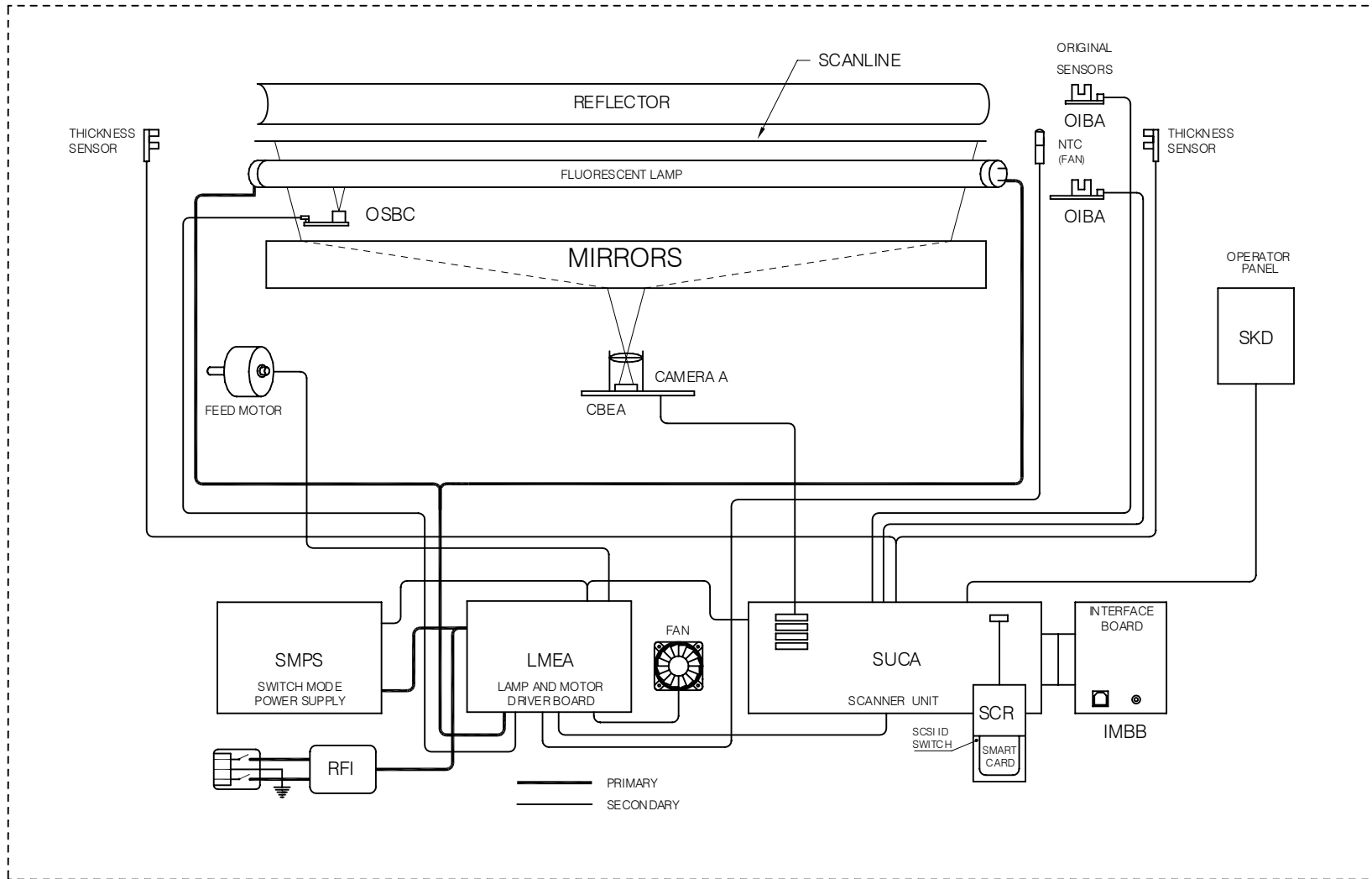

Fig. 2-2 CHAMELEON 25 Block Diagram

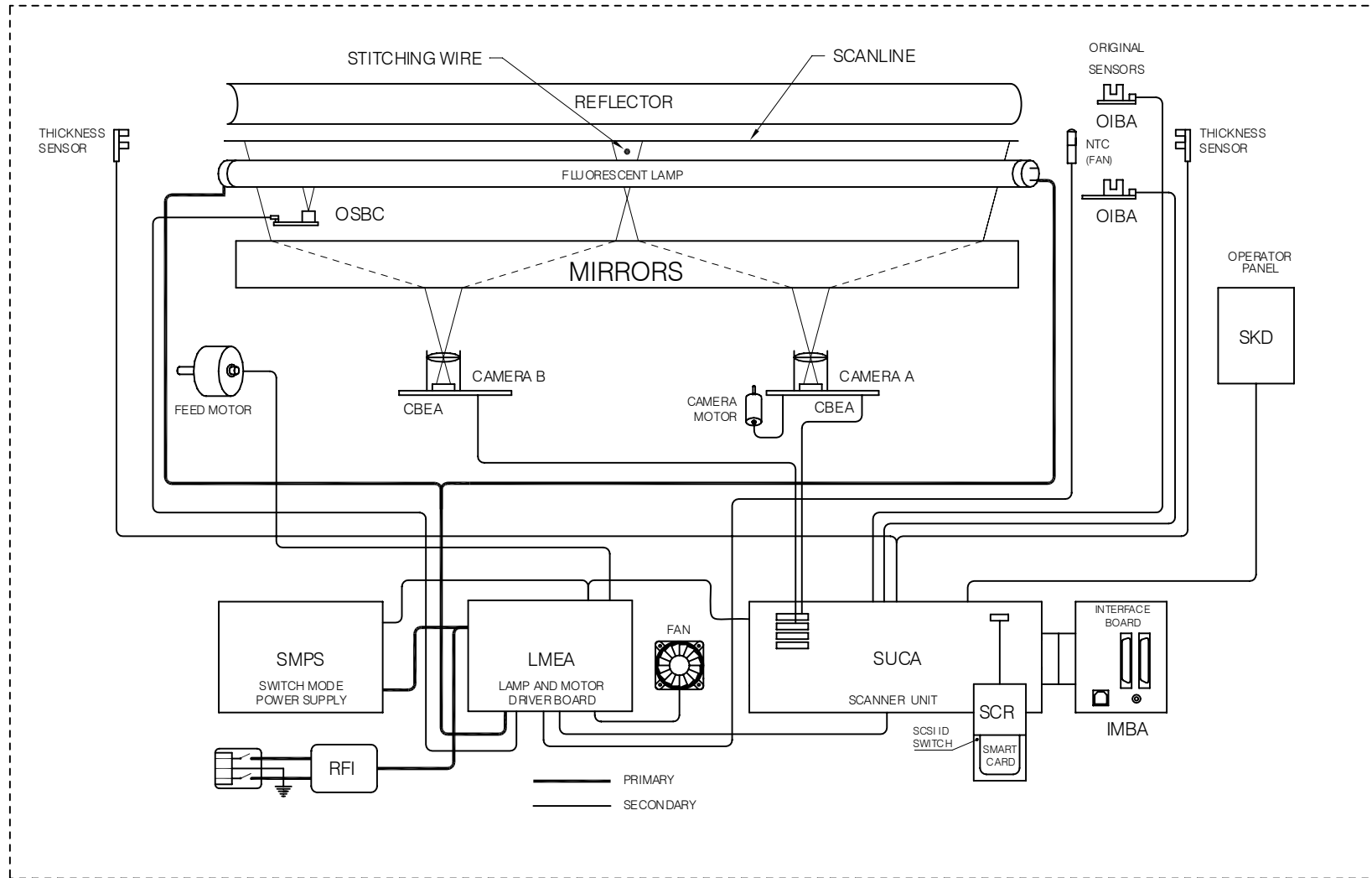

Fig. 2-3 COUGAR 36 Block Diagram

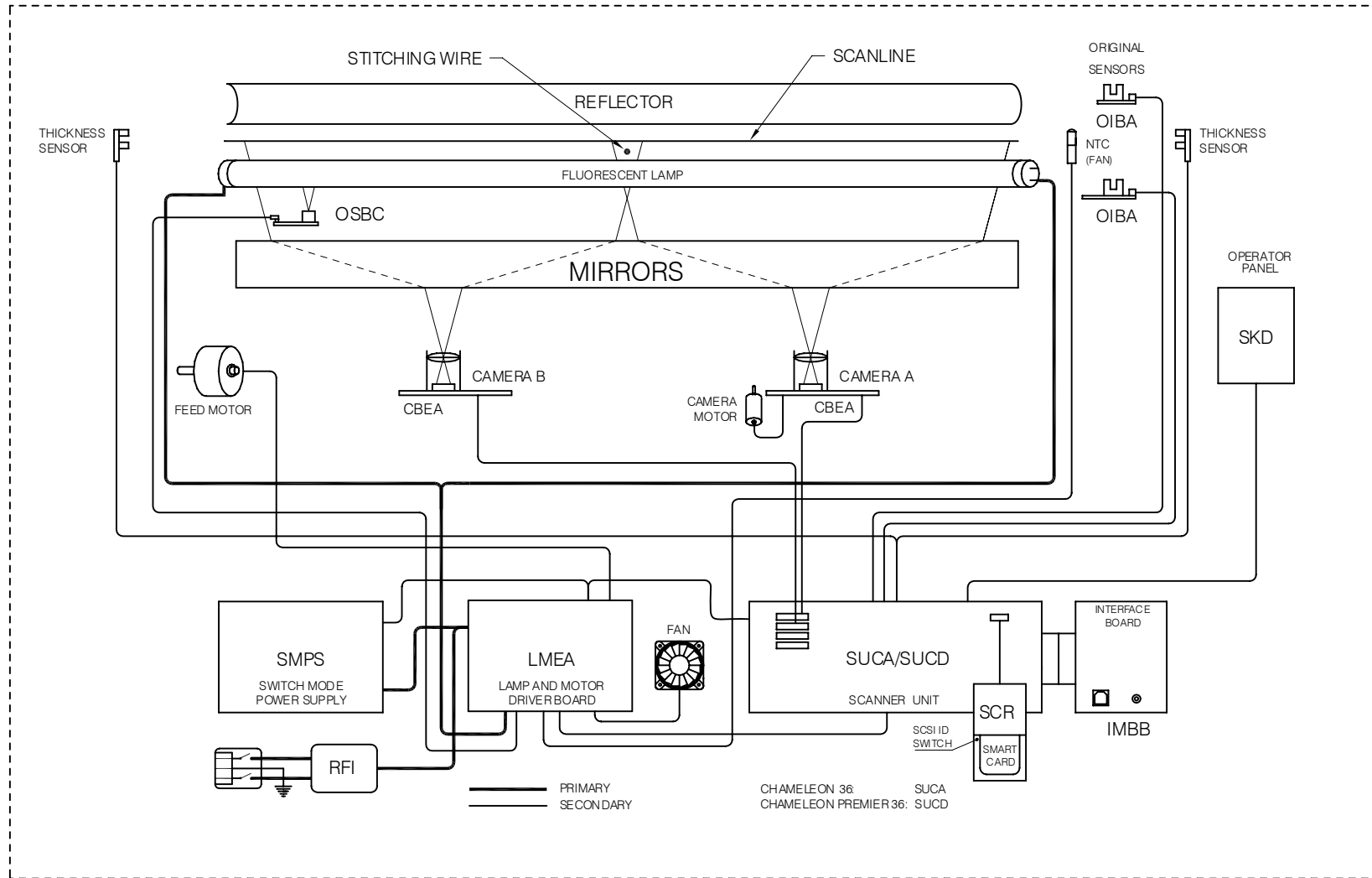

Fig. 2-4 CHAMELEON 36 and CHAMELEON PREMIER 36 Block Diagram

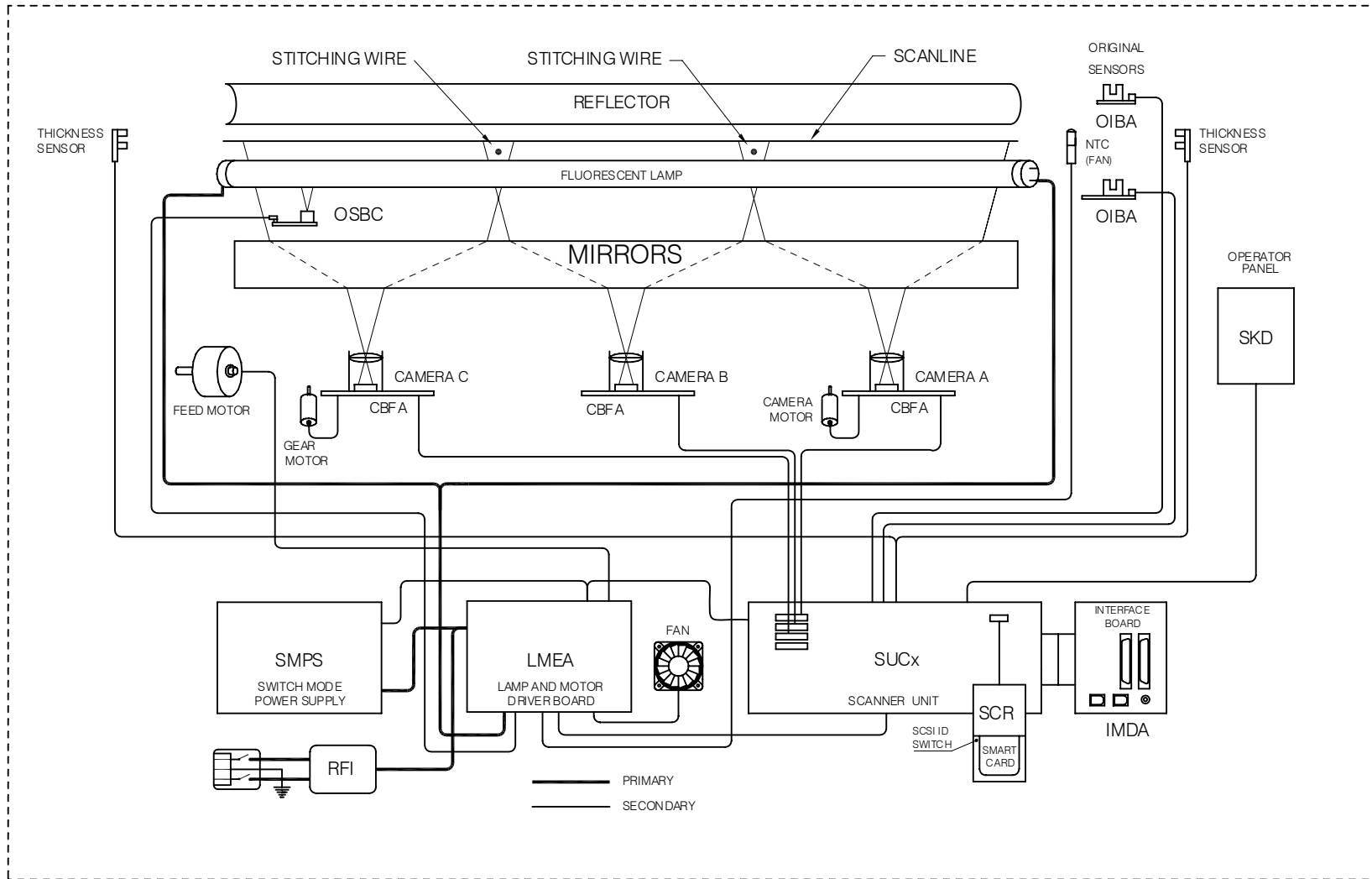

Fig. 2-5 CHROMA Tx 40 and CRYSTAL Tx 40 Block Diagram

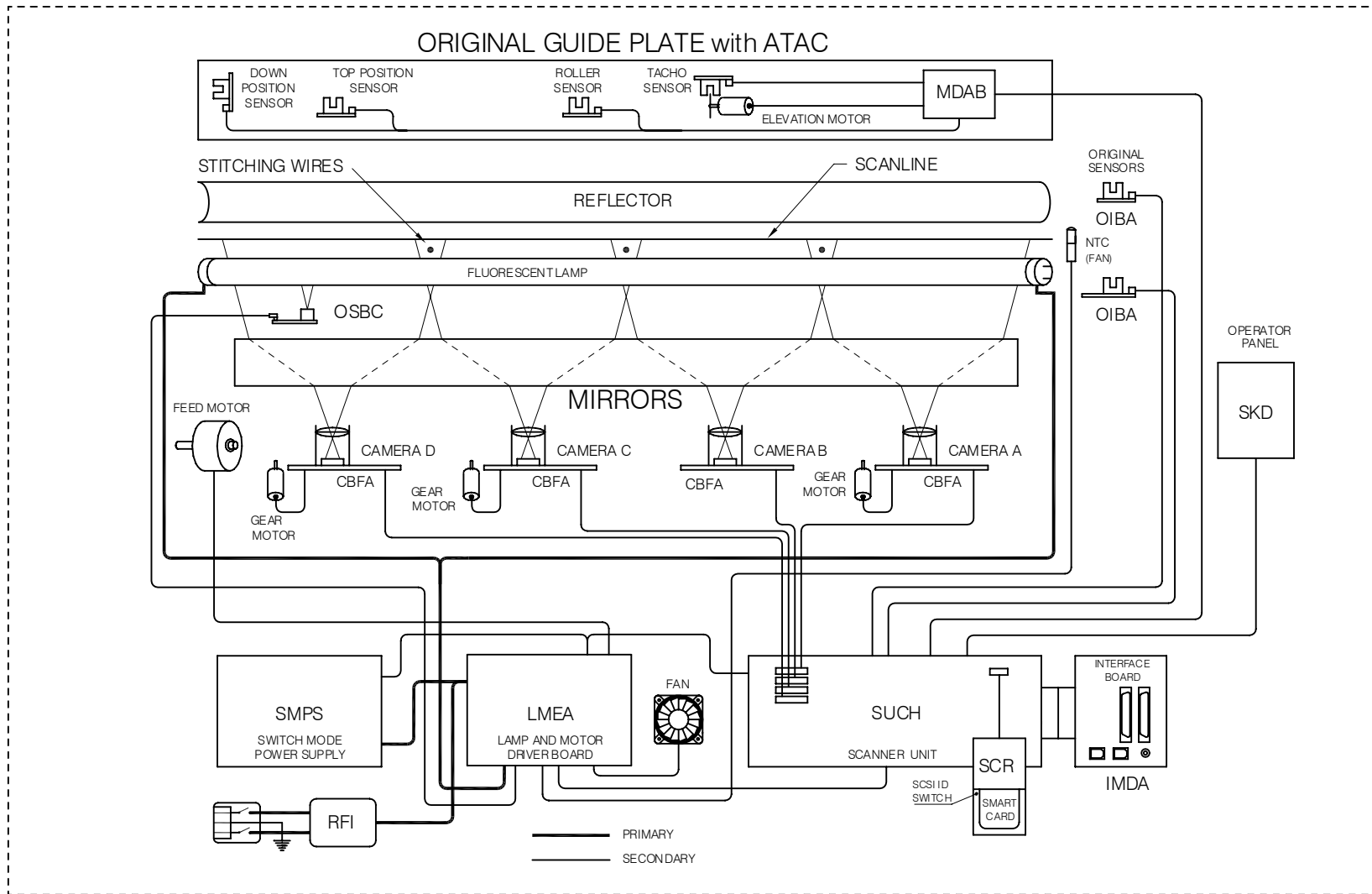

Fig. 2-6 MAGNUM XL 54 Block Diagram

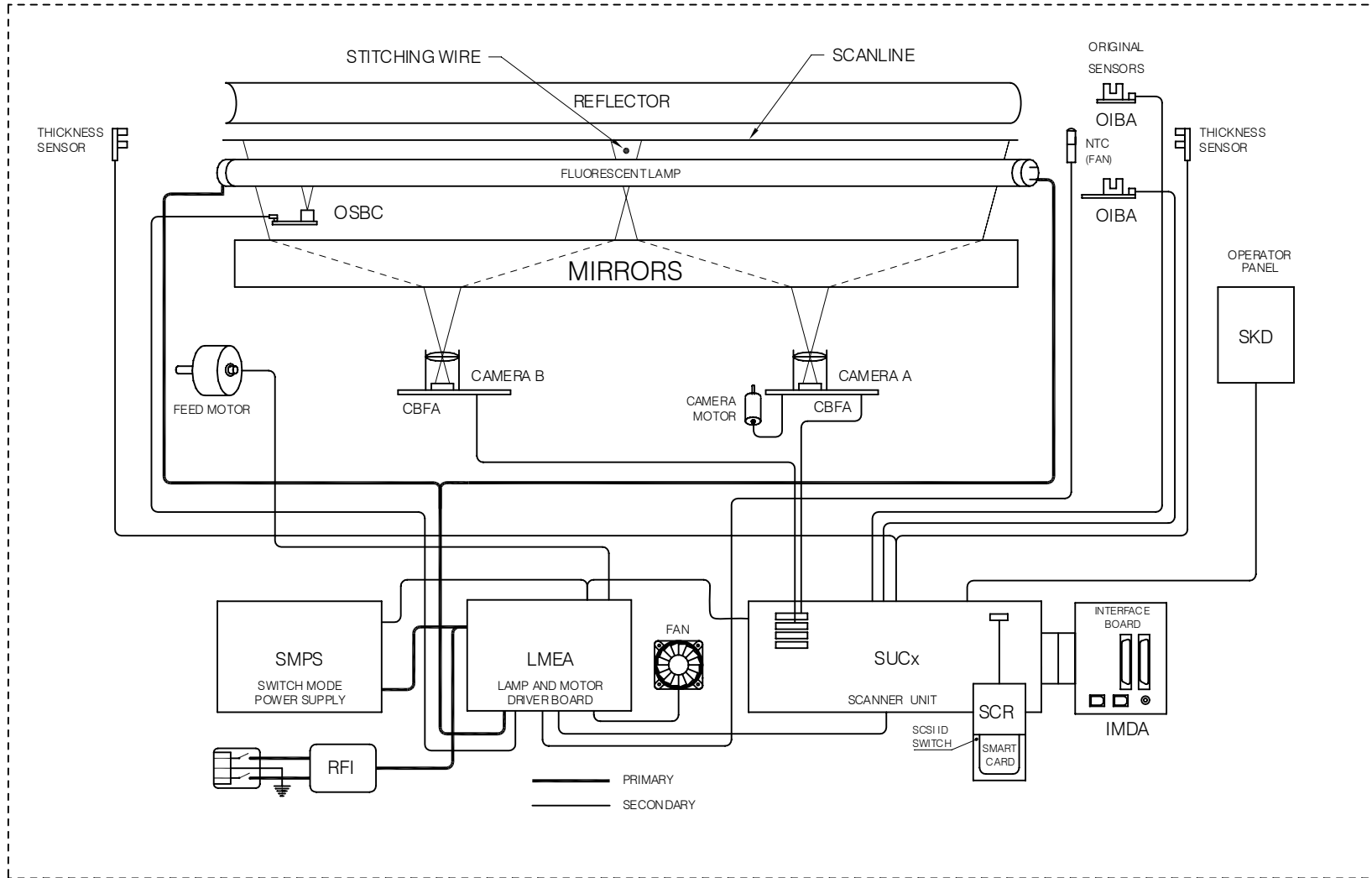

Fig. 2-7 COUGAR Tx 36, CHAMELEON Tx 36 and PREMIER Tx 36 Block Diagram

3. Electrical Check and Adjustments

Required Test Equipment:

Multimeter, $R_i > 10 \text{ MOhm}$

PC with SCANtest 6 and Scanner Maintenance installed, and

- USB and SCSI interface for COUGAR 25, 36
- USB interface for CHAMELEON 25, 36, PREMIER 36
- IEEE 1394 and SCSI for CHROMA Tx 40, CRYSTAL Tx 40
- IEEE 1394 and SCSI for MAGNUM XL 54
- IEEE 1394 and SCSI for COUGAR Tx 36, CHAMELEON Tx 36, and PREMIER Tx 36

SCANtest 6 is described in Chapter 10, page 171.

Scanner Maintenance is described in Section 6.1.7, page 142.

3.1 Marking Codes for Circuit Boards and Programmed Devices

All circuit boards are identified by a 4-letter code, where the fourth letter is designating a specific variant of the board. A board revision number follows the board identification code.

The marking of all newer printed circuit boards may be exemplified by the marking of the SUC-Board:

SUCA02

which designates SUC-Board, variant **A**, revision **2**.

The marking code of the older OIBA- and OSBC- Boards are a little different, for example:

OIBA-1.0

which designates OIB-Board, variant **A**, revision **1.0**.

The revision number is updated only if the functionality of the board has been changed.

Updated boards will always be backwards compatible.

Programmed components, like CPLDs, Flash Memory, etc., are marked with a 3- or 4-letter identification code, depending on whether the component is basic or variant specific. For example, the component marking:

SUC.003-2

identifies the Interface Controller used on all variants of the SUC-Board. **003** is a component specific number and **2** is the firmware revision number.

The variant designation (and part number) of the circuit boards used for a particular scanner model can be found in the Spare Part List included in the Technical Service Manual.

3.2 Downloading Scanner Firmware

The scanner firmware is stored in Flash Memory on the SUC-Board.

Scanner firmware is available on:

<http://www.contex.com/>

Firmware is downloaded to the scanner through the IEEE 1394, USB, or SCSI interface, please see *readme.txt* on the firmware disk for download instructions.

The download program:

CtxPrgm.exe

is started by double-clicking the self extracting *firmware.exe* file.

The download program reads the Download Control Switches, SW1 and SW2, on the SUC-Board to check if the actual firmware and the SUC hardware are compatible.

The Download Control Switches are factory set, and the setting must not be changed.

If the scanner does not go into Boot Mode when the download program is started, the scanner can be forced into Boot Mode by turning it OFF, setting SW7 on the SCSI ID-Switch to ON (see page 61), and turn the scanner back ON. The scanner will now be in Boot Mode and new firmware can be downloaded as described above. When the new firmware has been successfully downloaded, turn the scanner OFF, set SW7 back to OFF, and turn the scanner ON for normal operation.

3.2.1 Erase and Restore Parameter Blocks

The following two options may be found on the pull-down menu by right-clicking at the CtxPrgm icon in the title bar of the CtxPrgm window:

- Erase Parameter Blocks
- Restore Parameter Blocks

‘Erase Parameter Blocks’ erases the Parameter Blocks (Stitching, Basic Calibration, Color Calibration, etc.) in Flash Memory on the SUC-Board and save these in the file ‘backup.pmb’ located in the directory pointed to by the SET TEMP environment variable.

The file, backup.pmb, may be useful for diagnostic purposes.

‘Restore Parameter Blocks’ restores the Parameter Blocks from backup.pmb.

Note:

Always run Scanner Maintenance after Erase Parameter Blocks.

3.3 Check and Adjustment of the Switch Mode Power Supply, SMPS

All test points referred to below are shown in Fig. 3-1, page 29.

All DC voltages are measured relative to CN3, pin 1, 2, 3, 4, 5 (GND).

3.3.1 AC Voltages

CAUTION:

The connector CN1 is connected directly to the line voltage and constitute a risk of electric shock, or injury to persons.

3.3.2 DC Voltages

Ref. on Fig. 3-1	Ref. on SMPS	DC Voltage
CN3, pin 6,7,8	3.3V	+3.3 V \pm 0.1 V
CN3, pin 1,2,3,4,5	G	GND
CN2, pin 3,4,5	5V	+5.3 V +0/-0.1 V
CN2, pin 2	V3	+12 V + 1/-0 V
CN2, pin 1	V4	+24 V \pm 1 V

3.3.3 Adjustments

CAUTION:

The output voltages of the SMPS are all factory set and should normally not be adjusted.

The (5V) output voltage should be no more than 5.3 V measured between GND and CN2, pin 3,4,5 (5V) on the SMPS, and no less than 5.1 V measured between GND and C46, bottom on the CBE-Board respectively C918, bottom on the CBF-Board.

If the voltage is not within these limits, it may be adjusted by potentiometer SVR1 on the SMPS, see Fig. 3-1, page 29.

3.3.4 Fuses

The type and rating of the fuse on the SMPS is:

F1: F4A type IEC 127-2/2, UL R/C

CAUTION:

For continued protection against risk of fire, replace only with same type and rating of fuse.

3.3.5 Markings

No marking.

3.3.6 Jumper Settings

No jumpers.

3.3.7 Hints

+3.3 V is used as supply for the SUC-, CBE/CBF-, IMB/IMD-, and SKD-Boards.

+5.3 V is used as supply for LME-, CBE/CBF-, SUC-, IMB/IMD-Boards, and MDA-Board.

+12 V is used as supply for the LME- and CBE/CBF-Board, for the Camera Motor on the Camera Board and for the fan, and via the MDA-Board for the Elevation Motor (ATAC).

+24 V is used on the LME-Board for the Stepper Motor driver.

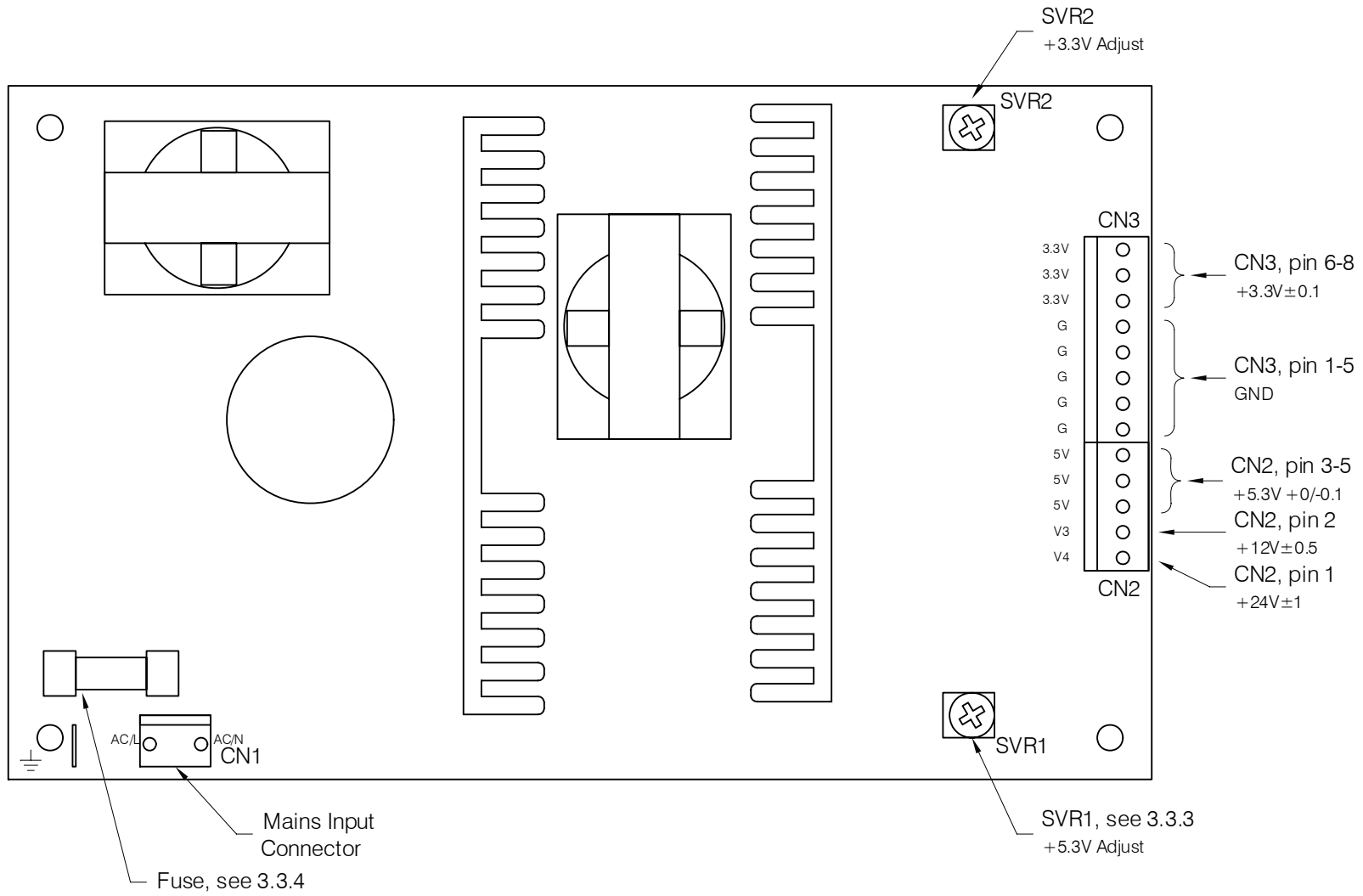

Fig. 3-1 SMPS Test Points

3.4 Check and Adjustment of Lamp and Motor Driver Board, LME

All test points referred to below are shown in Fig. 3-2, page 33.

All DC voltages are measured relative to test point GND.

LME Block Diagram is shown in Fig. 3-3, page 34.

CAUTION:

The connectors J1, J2, J4 and all the components on the left half of the board are connected to the line voltage and constitute a risk of electric shock, or injury to persons.

3.4.1 DC Voltages

Ref. on Fig. 3-2	DC Voltage
Test point GND	GND
J10, pin4 - GND	+5.3 V +0/-0.2 V
J10, pin5 - GND	+12.0 V + 1/-0 V
J10, pin6 - GND	+24.0 V \pm 1 V
TP9 - GND	-5.0 V \pm 0.5 V
TP3 – TP4 *	+200 V \pm 20 V
TP5 – TP4 *	-200 V \pm 20 V

* Caution: These test points are at high voltage level and constitute a risk of electric shock, or injury to persons.

3.4.2 Lamp-Driver Adjustment

Because of higher demands to the light level in later scanners, the general specification for the lamp driver adjustment has been changed. This change applies to all scanner models covered by this TSM.

The former specification where the voltage on TP7 from time to time was readjusted to a certain level gradually lowered the light level in the scanner. This is because the voltage on TP7 increases with lamp aging to compensate for drop in lamp efficiency. Or in other words, the older the lamp, the higher the voltage on TP7 for the same light level. The voltage on TP7 will therefore slowly increase over time and if readjusted the light level is lowered.

To ensure a constant predefined light level in the scanners throughout the lifetime of the lamp, the lamp driver should therefore **ONLY** be adjusted when the lamp is new. In this way the light level is kept at a known predefined level.

This means that the lamp driver is **ONLY** adjusted when changing either:

- the Lamp
- the Lamp Driver Board, LME
- the Lamp Sensor Board, OSB

and in order to do so the lamp **MUST** be new

Always replace the lamp before replacing the Lamp Driver Board

Adjustment Procedure:

Note: The voltage on TP7 is clamped to approximately 3.9 V. It may be necessary to turn P2 several turns CCW to bring the voltage below the clamp voltage.

1. Make sure that the lamp is new. If not it must be replaced
2. Remove the front cover of the scanner
3. Switch on the scanner
4. Wait for the lamp to switch on for the *second* time (after approx. 30 seconds)
5. Turn P2 CW until LED3 switches ON and then slowly CCW until LED3 switches OFF *
6. Leave the scanner on for 1 minute
7. Turn P2 CW until LED3 switches ON and then slowly CCW until LED3 switches OFF *
8. Replace the front cover
9. Reset the lamp counter:
 - Start SCANtest 6
 - Select Test 1 (Scanner Information)
 - Press the button “Reset Lamp Counter”
 - Type the password “xetnoc” and press “Reset Lamp Counter”
10. Run Scanner Maintenance to ensure correct Basic- and Color Calibration

* On early LME boards the LED’s are missing. In this case connect a voltmeter between TP7 and GND and adjust to –300mV. Note that the voltage will change slightly after adjustment, but this is normal and does not call for continued re-adjustments.

3.4.3 Signal LEDs on the LME-Board

The two indicators, LED3 and LED4, which are found on newer versions of the LME-Board, indicate the status of the stabilization circuit of the Lamp Driver. The two LEDs are controlled by the feedback voltage on TP7 and both LEDs will be ON as long as the feedback voltage is within the active range of the stabilization circuit. LED3 can however be OFF in a period of time right after a new lamp has been installed (and the lamp driver adjusted).

If LED4 is OFF it indicates that the stabilization circuit is close to or outside the active range and the lamp should be replaced.

3.4.4 Stepper Motor Reference Voltages

The stepper motor must be stopped for adjustment of the reference voltages.

Adjust P3 until the voltage on TP12 reads:

$$10 \text{ mV} \pm 10 \text{ mV}$$

Adjust P4 until the voltage on TP13 reads:

$$10 \text{ mV} \pm 10 \text{ mV}$$

3.4.5 Functional Test

SCANtest 6: Test 5, Lamp Test
Test 6, Motor Test

3.4.6 Fuses

The type and rating of the fuse on the LMEA-Board is:

F1: T2.0AH/250V, type IEC 127- 2/5, UL R/C

CAUTION:

For continued protection against risk of fire, replace only with same type and rating of fuse.

3.4.7 Markings

COUGAR 25	LMEAdd
COUGAR 36	LMEAdd
CHAMELEON 25	LMEAdd
CHAMELEON 36	LMEAdd
CHAMELEON PREMIER 36	LMEAdd
CHROMA Tx 40	LMEAdd
CRYSTAL Tx 40	LMEAdd
MAGNUM XL 54	LMEAdd
COUGAR Tx 36	LMEAdd
CHAMELEON Tx 36	LMEAdd
PREMIER Tx 36	LMEAdd
where dd = board revision number.	

3.4.8 Jumper Settings

Jumper:	SR1
pos:	A

3.4.9 Hints

Jumper on SR1: pos. A: Lamp controlled by SUC
 pos. B: Lamp constant ON
 No jumper: Lamp constant OFF

Control signals on J11:

pin 2: Lamp ON/OFF, LOW = ON
 pin 8: Feed-Motor Step Pulse
 pin 11: Feed-Motor Direction, LOW = FORWARD

Fan Speed Control:

A NTC Temperature Sensor located under the End Cover at the Operator Panel end of the scanner controls the speed of the fan connected to J7.

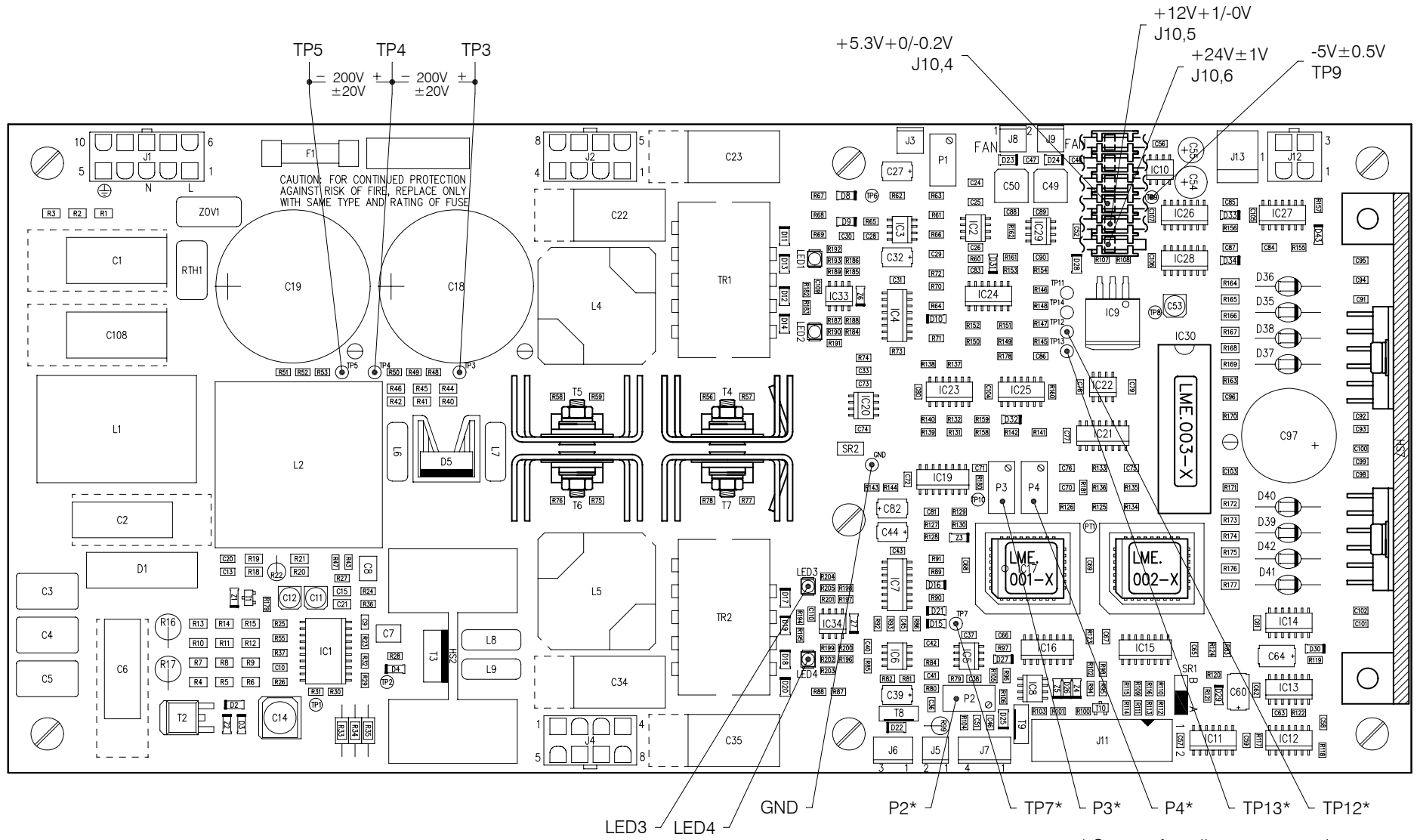

* See text for adjustment procedure

Fig. 3-2 LME Component Layout

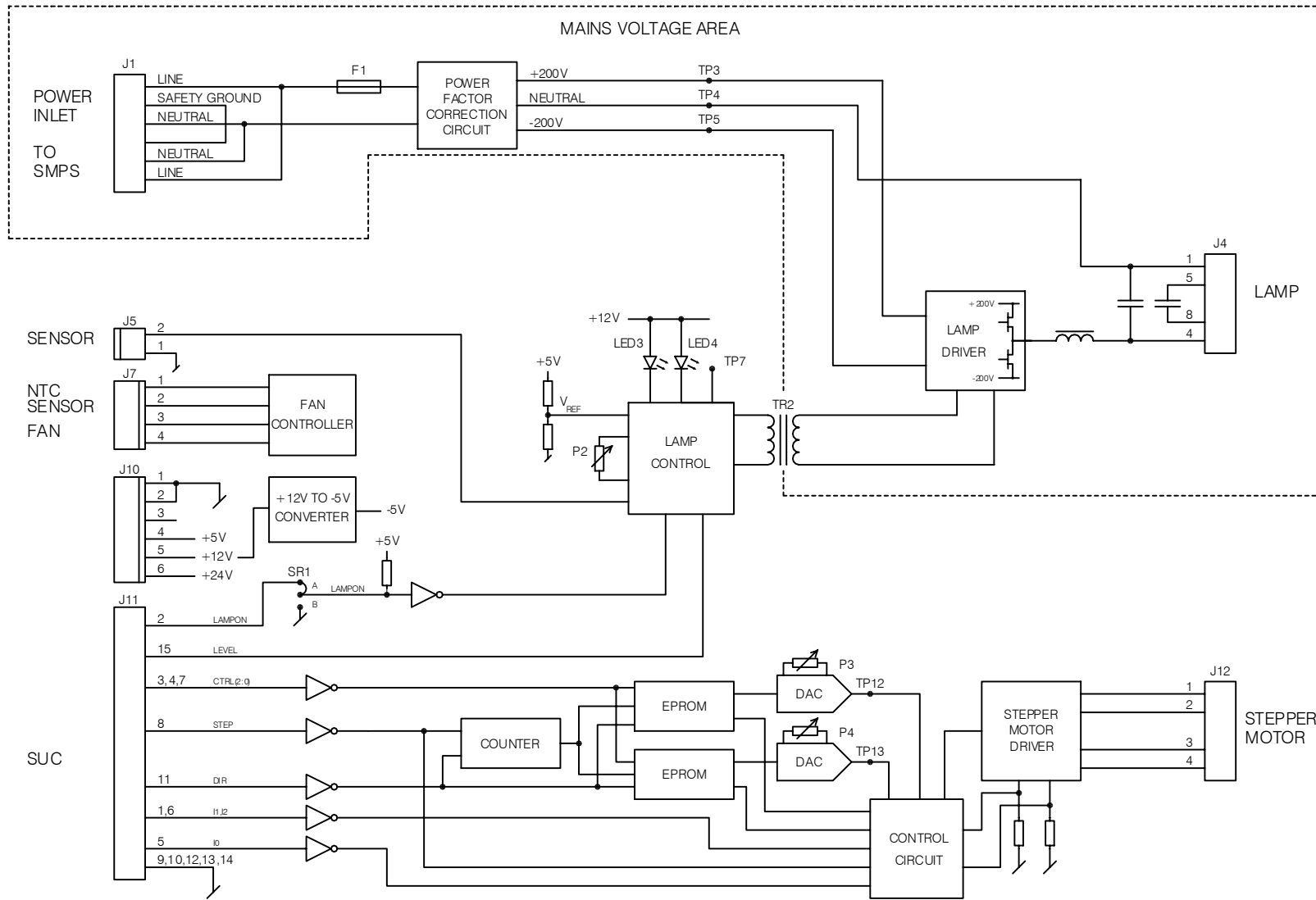

Fig. 3-3 LME Block Diagram

3.5 Check and Adjustment of Camera Board, CBE (non Tx and XL models)

All test points referred to are shown in Fig. 3-4, page 37.

All voltages are measured relative to test point GND.

CBE Block Diagram is shown in Fig. 3-5, page 38.

3.5.1 DC Voltages

Ref. on Fig. 3-4	DC Voltage	Remarks
C46, bottom	+5.3 V +0/-0.2 V	From SUC / SMPS
C125, top	+4.85 V +0.1/-0.2 V	Derived from +5.3V on CBE
C14, bottom	+12.0 V +1/-0 V	From SUC / SMPS, used for CCD and Camera Motor
C32, right	+3.3 V \pm 0.1 V	From SUC / SMPS

3.5.2 Adjustments

The gain and offset of the CBE-Board are adjusted automatically by running Scanner Maintenance.

3.5.3 Functional Test

SCANtest 6: Test 7, Complete Hardware Test

3.5.4 Markings

COUGAR 25	CBEAdd
COUGAR 36	CBEAdd
CHAMELEON 25	CBEAdd
CHAMELEON 36	CBEAdd
CHAMELEON PREMIER 36	CBEAdd
where dd = board revision number.	

3.5.5 Jumper Settings

No jumpers.

3.5.6 Hints

+3.3 V, +5.3 V, and +12 V is supplied from the SMPS via the SUC-Board.

CCD

The lines of pixels on the CCD are covered by color filters and arranged as follows:

Upper line on the CCD:	Blue
Center line on the CCD:	Green
Lower line on the CCD:	Red

As the image is mirrored an even number of times (mirror chassis and lens), the Blue line remains upper line when referred to the original.

Control of Camera Motor

The Camera Motor for Vertical Alignment is driven from a controller IC on the CBE-Board. The supply voltage for the motor is +12 V.

After replacement of CBE-Board, do:

- CCD-Centering, Section 4.2.6, page 109.
- Vertical Positioning, Section 4.2.7, page 110.
- Check Scan-Width, if it is within the limits given in Section 4.2.5, page 99, Focus will also be OK, and no further adjustments are required.
- Run Scanner Maintenance, Section 6.1.7, page 142.

These adjustments can be made without loosening the Camera Fixing Screws and without loosening the Focus Lock Ring / Lock Screw.

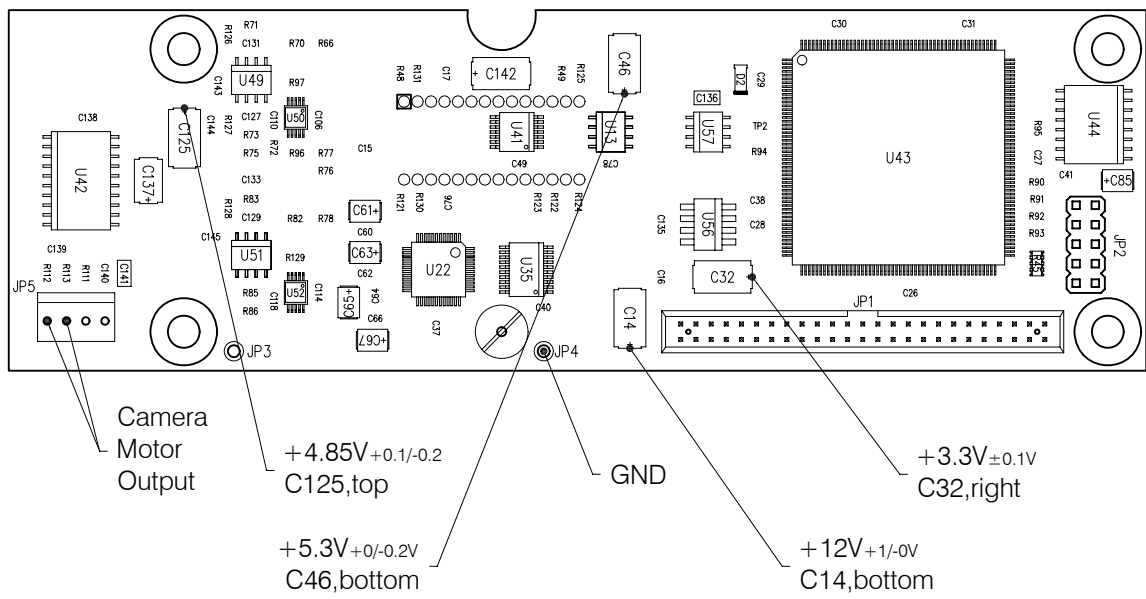

Fig. 3-4 CBE Component Layout

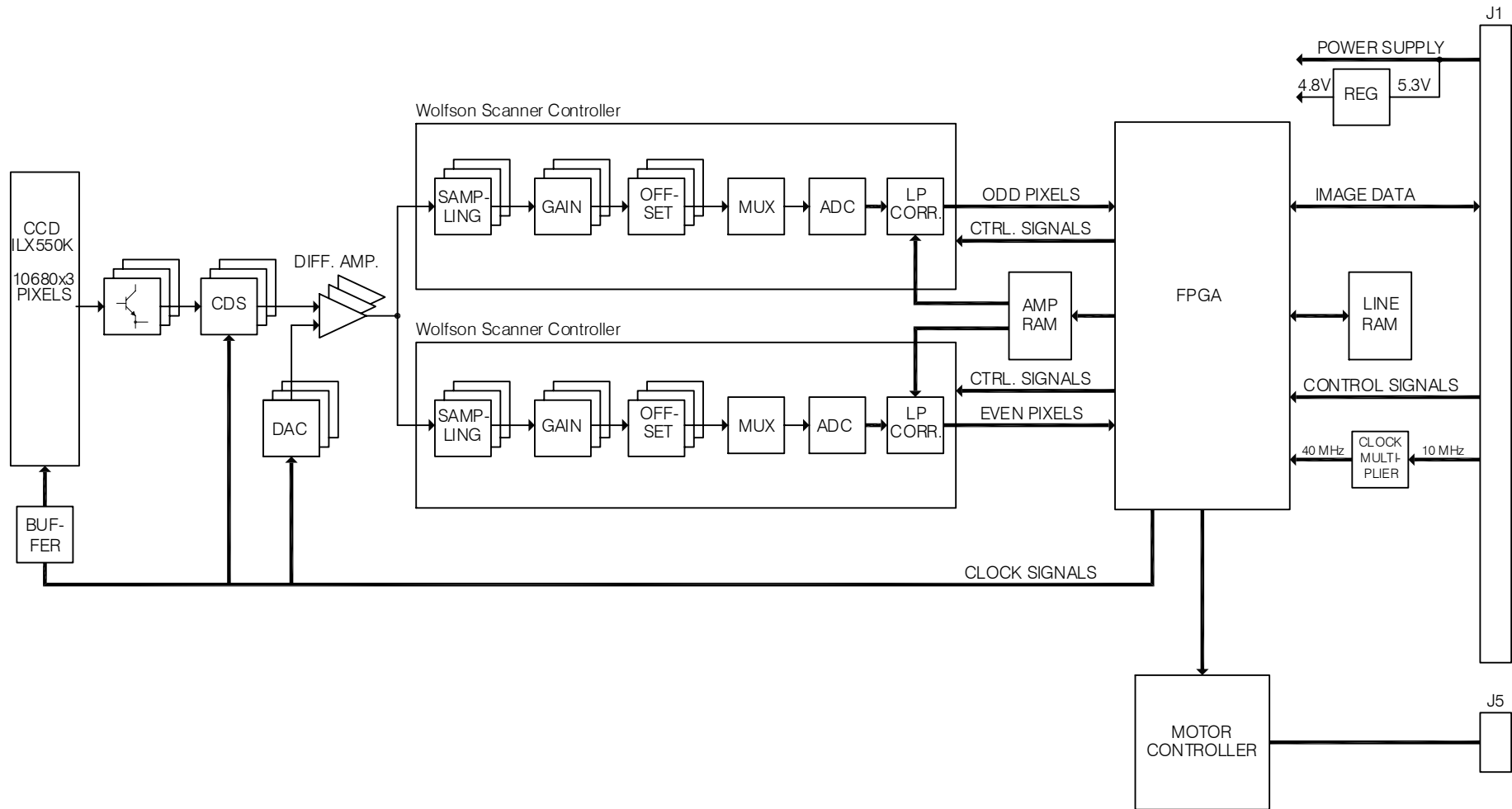

Fig. 3-5 CBE Block Diagram

3.6 Check and Adjustment of Camera Board, CBF (Tx and XL models)

All test points referred to are shown in Fig. 3-6, page 41.

All voltages are measured relative to test point GND.

CBF Block Diagram is shown in Fig. 3-7, page 42.

3.6.1 DC Voltages

Ref. on Fig. 3-6	DC Voltage	Remarks
C918, bottom	+5.3 V +0/-0.2 V	From SUC / SMPS
C901, bottom	+3.3 V \pm 0.1 V	From SUC / SMPS
IC1101, pin 19	+12.0 V +1/-0 V	From SUC / SMPS, used for CCD and Camera Motor
C921, bottom	+5 V \pm 0.2 V	From On-Board Regulators
C917, left	+5 V \pm 0.2 V	From On-Board Regulators
C913, bottom	+5 V \pm 0.2 V	From On-Board Regulators
C905, top	+2.5 V \pm 0.1 V	From On-Board Regulators
Q102, bottom	+11.6 V \pm 0.6 V	From On-Board Regulators

3.6.2 Adjustments

The gain and offset of the CBF-Board are adjusted automatically by running Scanner Maintenance.

3.6.3 Functional Test

SCANtest 6: Test 7, Complete Hardware Test

3.6.4 Markings

CHROMA Tx 40	CBFAdd
CRYSTAL Tx 40	CBFAdd
MAGNUM XL 54	CBFAdd
COUGAR Tx 36	CBFAdd
CHAMELEON Tx 36	CBFAdd
PREMIER Tx 36	CBFAdd
where dd = board revision number.	

3.6.5 Jumper Settings

No jumpers.

3.6.6 Hints

+3.3 V, +5.3 V, and +12 V is supplied from the SMPS via the SUC-Board.

On-Board Regulators are supplied from the SMPS via the SUC-Board.

CCD

The lines of pixels on the CCD are arranged as follows:

Upper line on the CCD:	Red
2nd line on the CCD:	Green

3rd line on the CCD: Blue
Lower line on the CCD: B/W

As the image is mirrored an even number of times (mirror chassis and lens), the Red line remains upper line when referred to the original.

Control of Camera Motor

The Camera Motor for Vertical Alignment is driven from a controller IC on the CBF-Board. The supply voltage for the motor is +12 V.

After replacement of CBF-Board, do:

- CCD-Centering, Section 4.2.6, page 109.
- Vertical Positioning, Section 4.2.7, page 110.
- Check Scan-Width, if it is within the limits given in Section 4.2.5, page 99, Focus will also be OK, and no further adjustments are required.
- Run Scanner Maintenance, Section 6.1.7, page 142.

These adjustments can be made without loosening the Camera Fixing Screws and without loosening the Focus Lock Ring / Lock Screw.

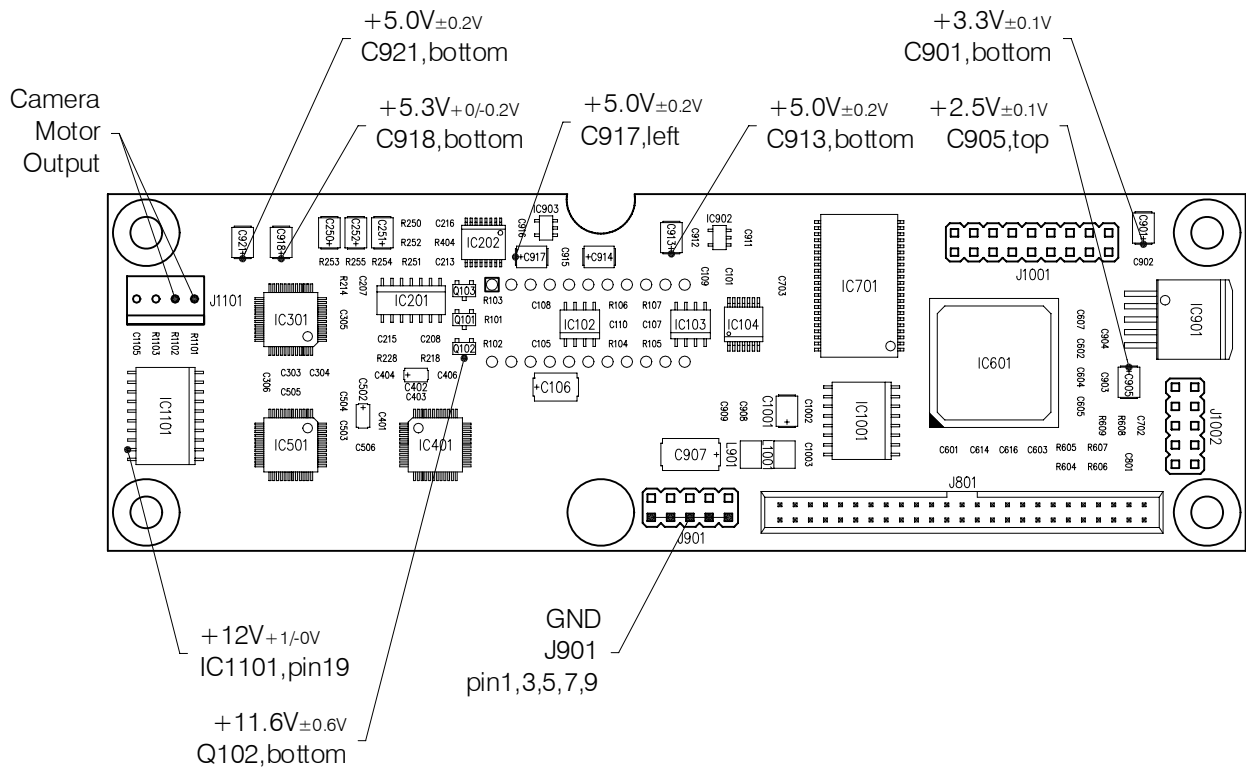

Fig. 3-6 CBF Component Layout

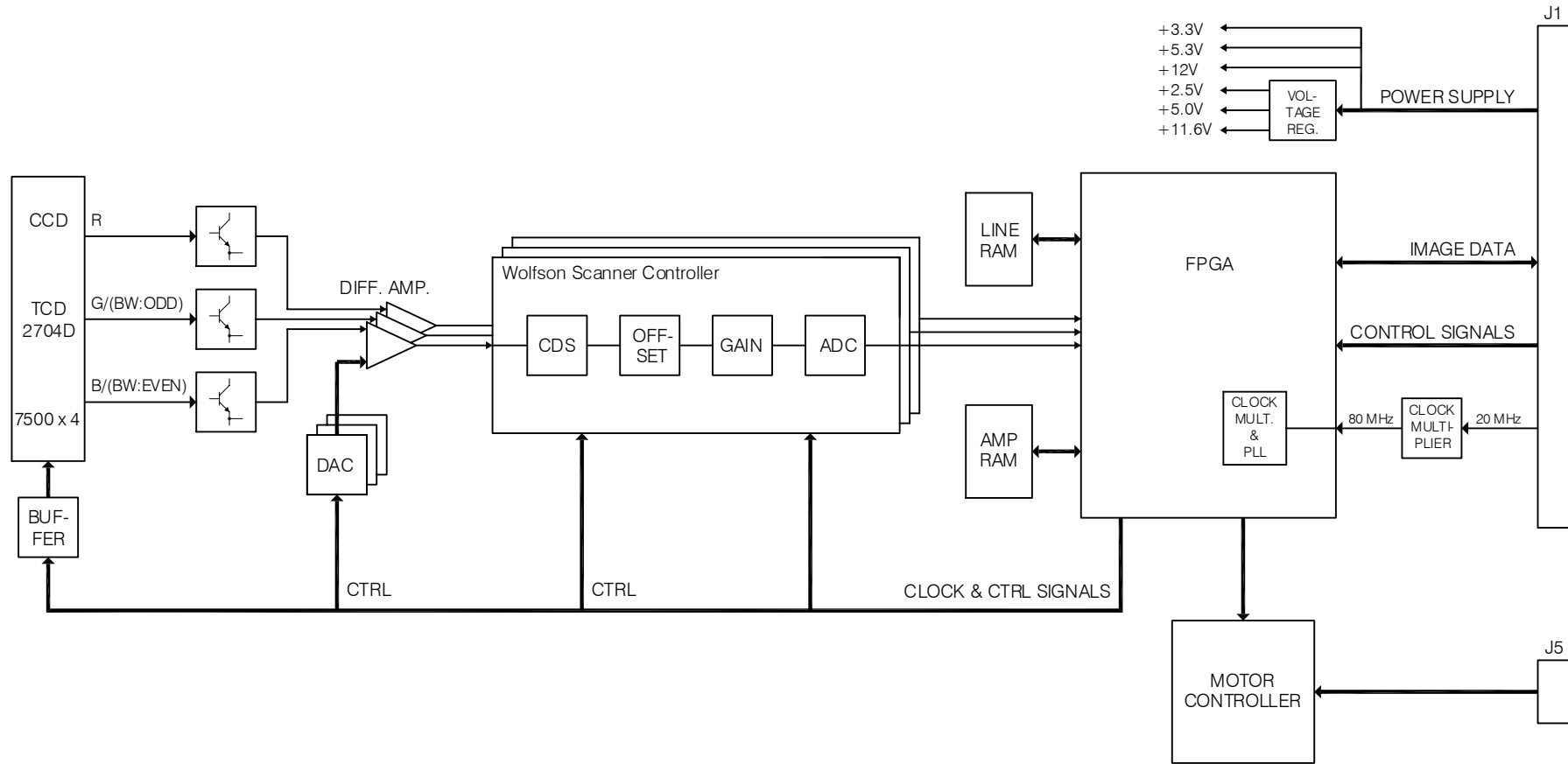

Fig. 3-7 CBF Block Diagram

3.7 Check of Controller Board, SUC

All test points referred to below are shown in Fig. 3-8, page 45.

All voltages are measured relative to test point GND2.

SUC Block Diagram is shown in Fig. 3-9, page 46.

3.7.1 DC Voltages

Ref. on Fig. 3-8	DC Voltage	Remarks
12V_CAM	+12 V + 1/-0V	Supply for Camera Board, Elevation Motor (ATAC)
5V_CAM	+5.3 V +0/-0.2 V	Supply for Camera Board, MDA Board (ATAC)
+3	+3.3 V \pm 0.1 V	
+5V	+5.1 V +0.1/-0.2 V	Derived from 5.3V on SUC
APEX_SUP	+1.8 V \pm 0.1 V	
APEX_PLL	+1.8 V \pm 0.05 V	

3.7.2 Adjustments

No adjustments.

3.7.3 Functional Test

SCANtest 6: Test 1 Scanner Information
Test 7, Complete Hardware Test

3.7.4 Markings

Note: SUC variant depends on scanner model.

COUGAR 25	SUCAdd
COUGAR 36	SUCAdd
CHAMELEON 25	SUCAdd
CHAMELEON 36	SUCAdd
CHAMELEON PREMIER 36	SUCDdd
CHROMA Tx 40	SUCBdd
CRYSTAL Tx 40	SUCCdd
MAGNUM XL 54	SUCHdd
COUGAR Tx 36	SUCBdd
CHAMELEON Tx 36	SUCCdd
PREMIER Tx 36	SUCGdd
where dd = board revision number.	

3.7.5 Switch Settings (Download Control Switches)

The download program reads the Download Control Switches, SW1 and SW2, on the SUC-Board to check if the actual firmware and the SUC hardware are compatible.

The Download Control Switches are factory set, and the setting must not be changed.

3.7.6 Jumper Settings

No jumpers.

3.7.7 Signal LEDs on the SUC-Board

The three signal LEDs on the SUC-Board are for debugging purposes only. The ON/OFF pattern displayed by these LEDs is not intended for general troubleshooting.

3.7.8 Hints

After replacement of SUC-Board:

As all scanner parameters are stored in the Flash Memory on the SUC-Board, the following steps should be carried out after replacement of the SUC-Board:

- Download Firmware
- Run Scanner Maintenance
- Enter Serial Number of scanner into Flash Memory (SCANtest 6, Test 1). The serial number of the scanner is found on the marking label on back of the scanner

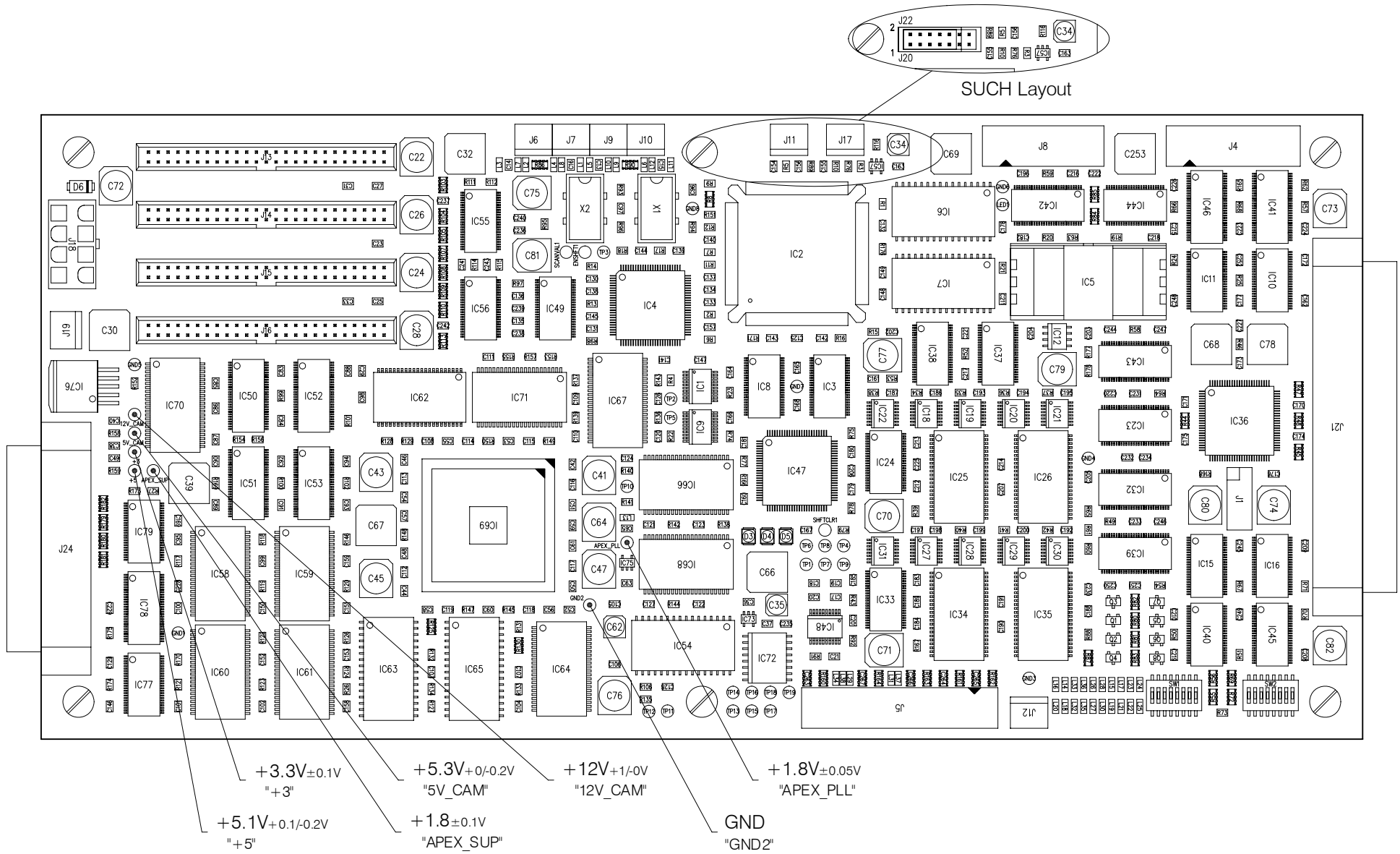

Fig. 3-8 SUC Component Layout

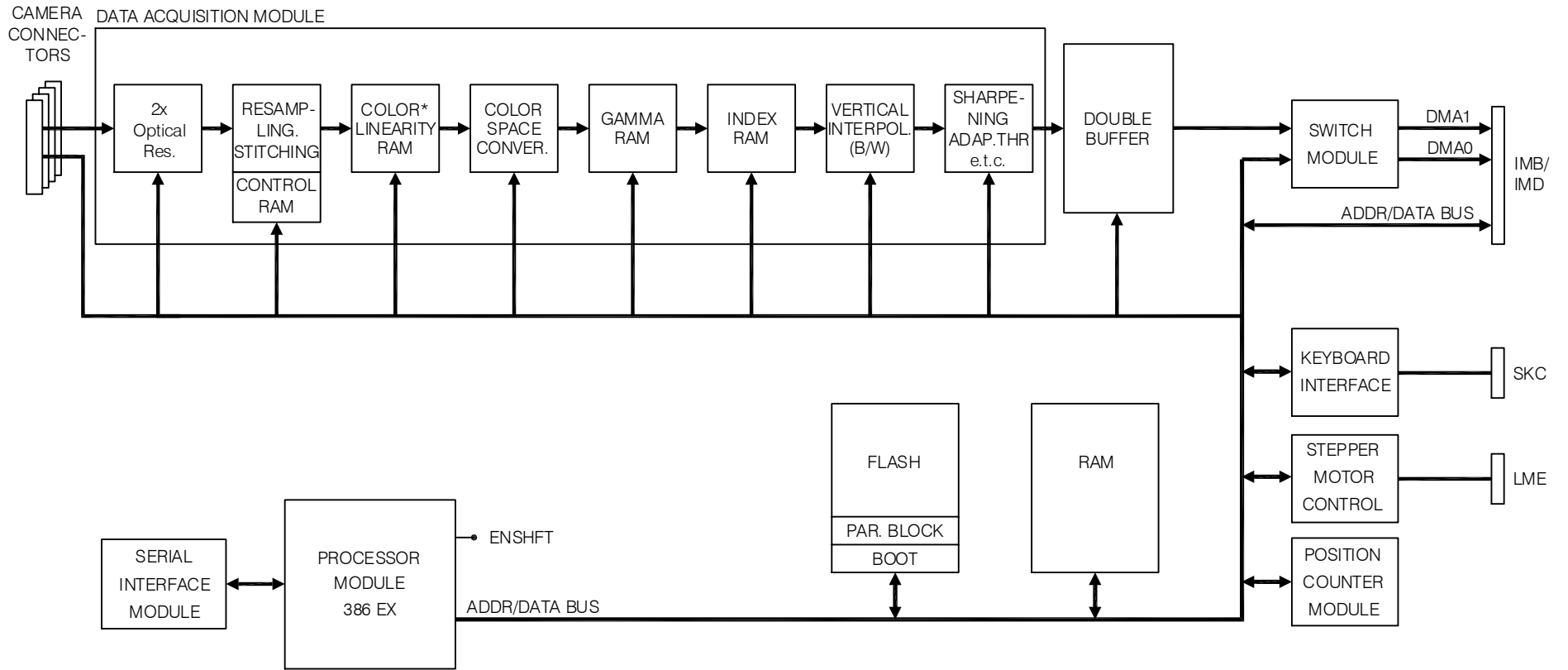

Fig. 3-9 SUC Block Diagram

3.8 Check of Interface Module, IMB (non Tx and XL models)

All test points referred to below are shown in Fig. 3-10, page 49.

All voltages are measured relative to test points GND_T1.

IMB Block Diagram is shown in Fig. 3-11, page 50.

3.8.1 DC Voltages

Ref. on Fig. 3-10	DC Voltage
R34,top	+5.3 V +0/-0.2 V
+5V_D1	+5.2 V +0/-0.2 V
+3.3V_D1	+3.3 V \pm 0.1 V
D2,top (cathode)*	+5.0 V +0.1/-0.2 V

*) SCSI Terminal Power, on IMBA only.

3.8.2 Adjustments

No adjustments.

3.8.3 Functional Test

Connect the computer to USB and SCSI (SCSI on COUGAR only) and start SCANtest 6 (or WIDEimage) to check if the scanner is connecting on all ports available:

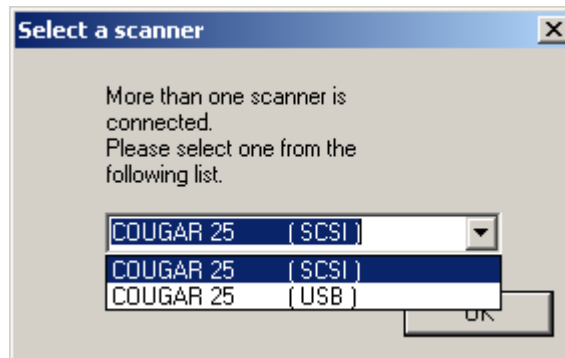

3.8.4 Markings

COUGAR 25	IMBAdd
COUGAR 36	IMBAdd
CHAMELEON 25	IMBBdd
CHAMELEON 36	IMBBdd
CHAMELEON PREMIER 36	IMBBdd
where dd = board revision number.	

3.8.5 Jumper Settings

No jumpers.

3.8.6 Hints

The SCSI ID is set on a DIP switch located on the Smart Card Reader.

The setting of the SCSI ID switch is shown in Section 3.11.4, page 60.

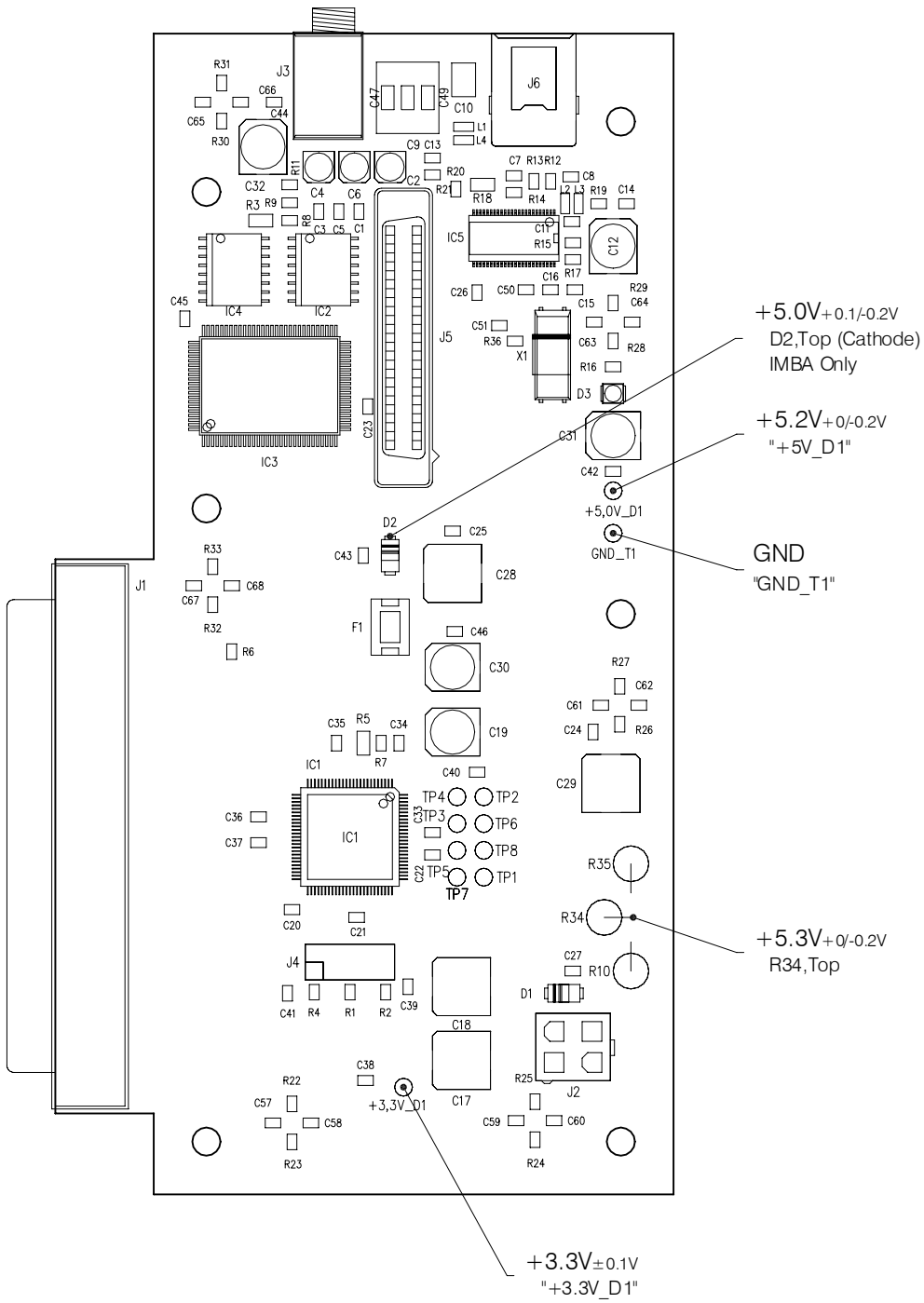

Fig. 3-10 IMB Component Layout

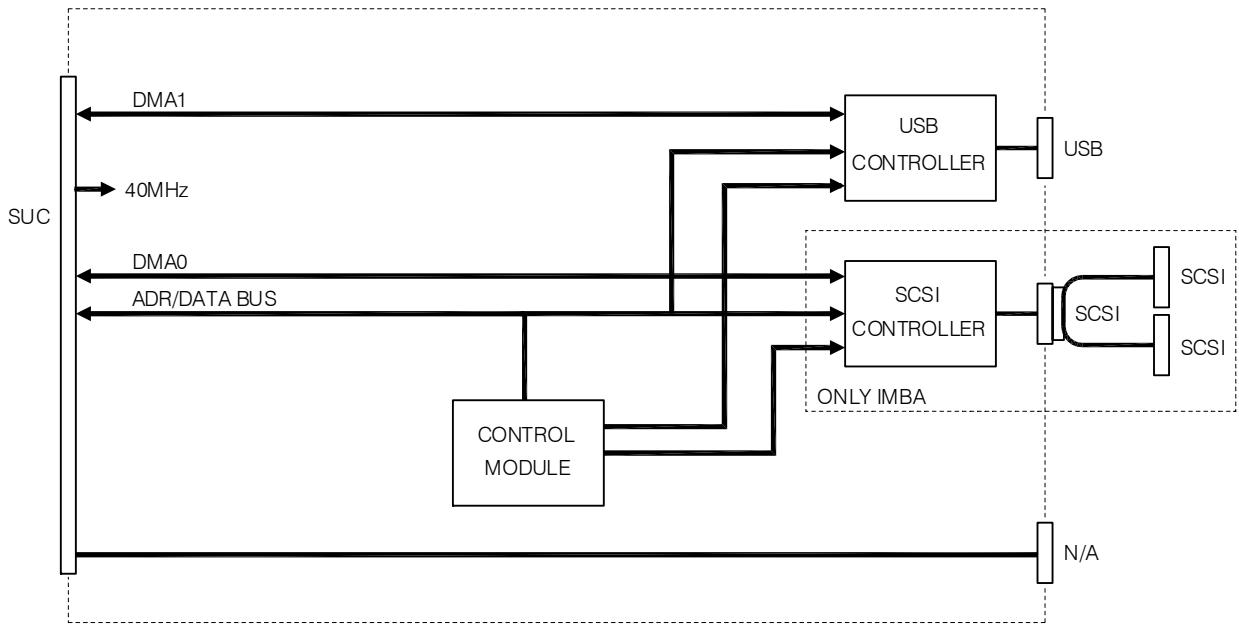

Fig. 3-11 IMB Block Diagram

3.9 Check of Interface Module, IMD (Tx and XL models)

All test points referred to below are shown in Fig. 3-12, page 52.

All voltages are measured relative to test points GND_T1.

IMD Block Diagram is shown in Fig. 3-12, page 53.

3.9.1 DC Voltages

Ref. on Fig. 3-12	DC Voltage
R34,top	+5.3 V +0/-0.2 V
+5V_D1	+5.2 V +0/-0.2 V
+3.3V_D1	+3.3 V \pm 0.1 V
D2,Cathode (bottom) *	+5.0 V +0.1/-0.2 V

*) SCSI Terminal Power

3.9.2 Adjustments

No adjustments.

3.9.3 Functional Test

Connect the computer to each separate port in turn and start SCANtest 6 or WIDEimage to check if the scanner is connecting on all ports available.

3.9.4 Markings

CHROMA Tx 40	IMDAdd
CRYSTAL Tx 40	IMDAdd
MAGNUM XL 54	IMDAdd
COUGAR Tx 36	IMDAdd
CHAMELEON Tx 36	IMDAdd
PREMIER Tx 36	IMDAdd
where dd = board revision number.	

3.9.5 Jumper Settings

No jumpers.

3.9.6 Hints

The SCSI ID is set on a DIP switch located on the Smart Card Reader.

The setting of the SCSI ID switch is shown in Section 3.11.4, page 60.

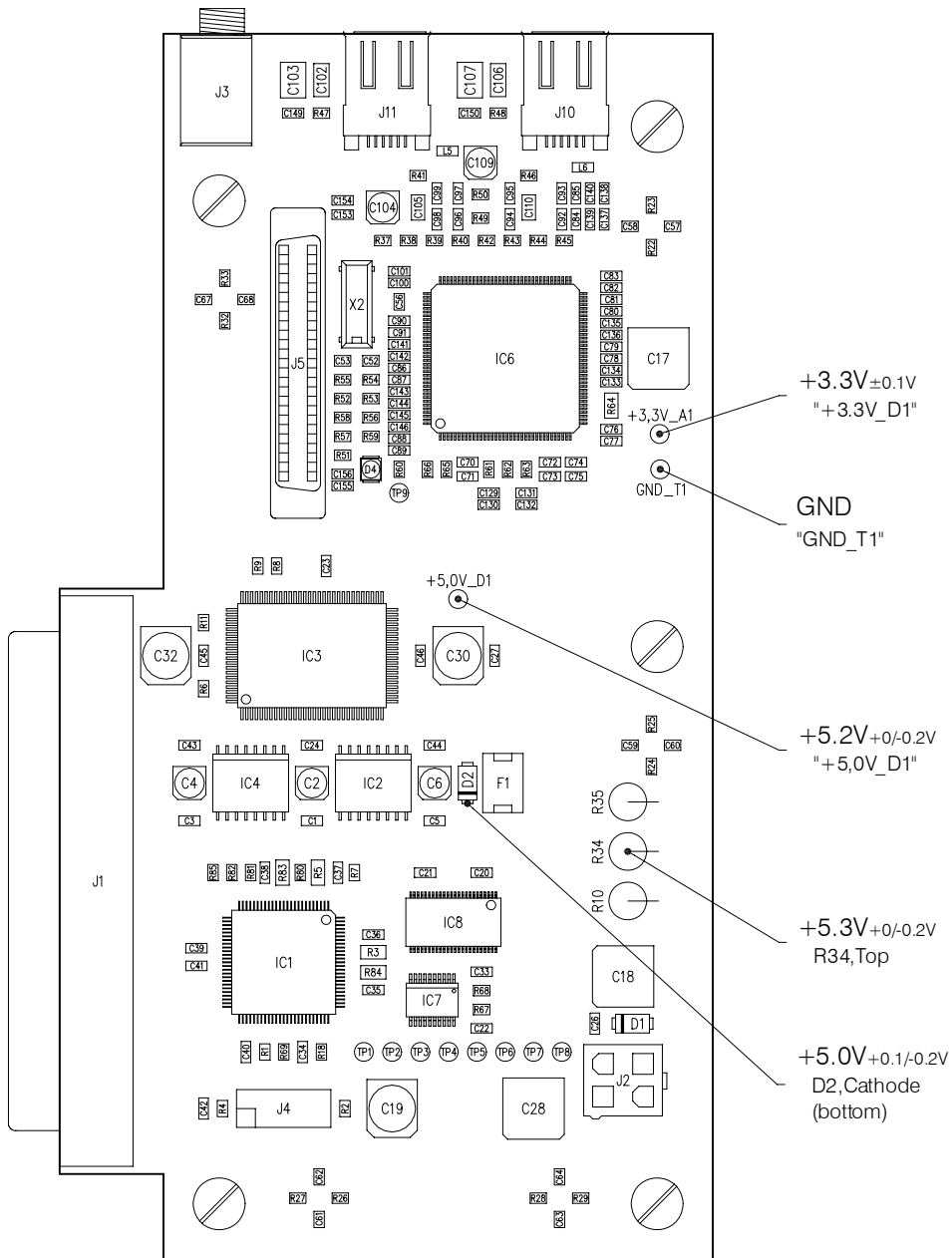

Fig. 3-12 IMD Component Layout

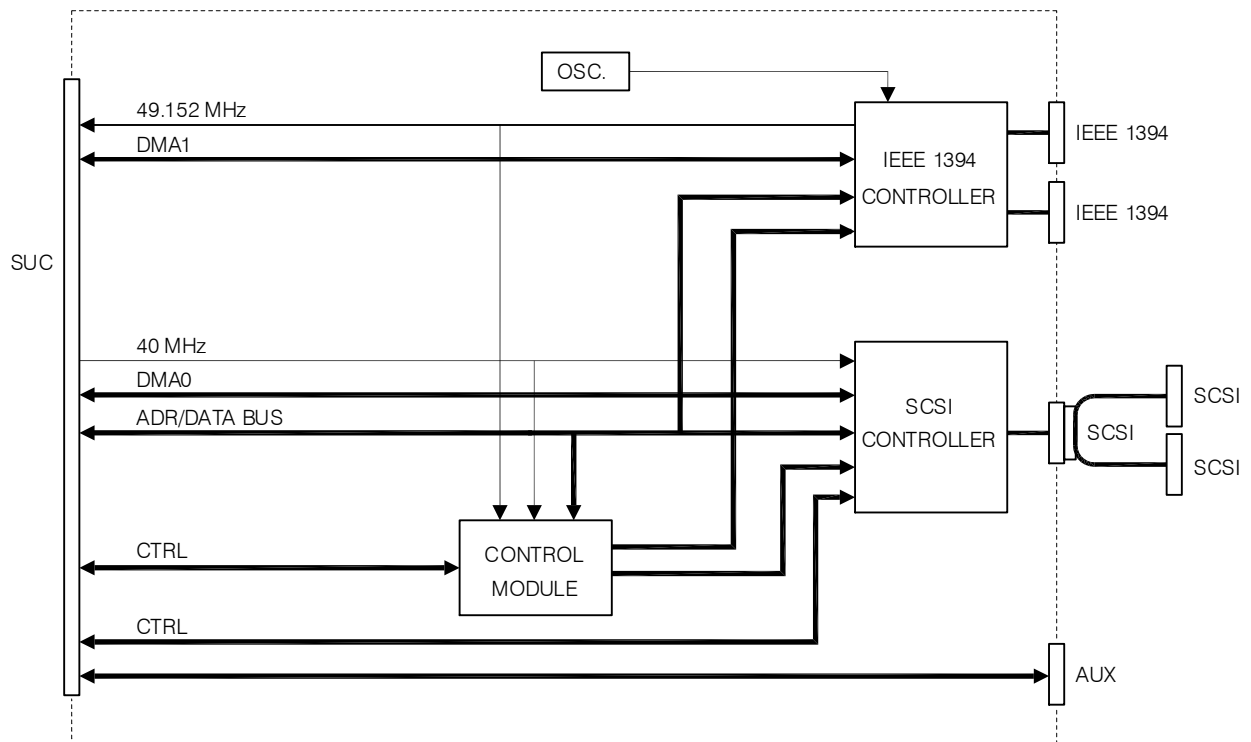

Fig. 3-13 IMD Block Diagram

3.10 Check of Operator Panel, SKD

All test points referred to are shown in Fig. 3-14, page 56 and Fig. 3-16, page 58.

All voltages are measured relative to PCB Ground Plane.

SKDA Block Diagram is shown in Fig. 3-15, page 57.

SKDF Block Diagram is shown in Fig. 3-16, page 58.

3.10.1 DC Voltages

Ref. on Fig. 3-14 and Fig. 3-18	DC Voltage
J2, pin 3	+3.3 V \pm 0.1 V
C1, top	+5.1 V +0.1/-0.2 V

3.10.2 Functional Test

SCANtest 6: Test 1, Scanner ID Switch

Test 2, LED test

Test 3, Key test

3.10.3 Markings

COUGAR 25	SKDAdd
COUGAR 36	SKDAdd
CHAMELEON 25	SKDAdd
CHAMELEON 36	SKDAdd
CHAMELEON PREMIER 36	SKDAdd
CHROMA Tx 40	SKDAdd
CRYSTAL Tx 40	SKDAdd
MAGNUM XL 54	SKDFdd
COUGAR Tx 36	SKDAdd
CHAMELEON Tx 36	SKDAdd
PREMIER Tx 36	SKDAdd
where dd = board revision number.	

3.10.4 Switch Setting (Scanner ID)

DIP Switch Setting:

	SW 1	SW 2	SW 3	SW 4	SW 5	SW 6	SW 7	SW 8	HE X
COUGAR 25	OFF	OFF	OFF	ON	OFF	OFF	OFF	OFF	0x10
COUGAR 36	OFF	OFF	OFF	ON	OFF	OFF	OFF	ON	0x11
CHAMELEON 25	OFF	OFF	OFF	ON	OFF	OFF	ON	OFF	0x12
CHAMELEON 36	OFF	OFF	OFF	ON	OFF	OFF	ON	ON	0x13
CHAMELEON PREMIER 36	OFF	OFF	OFF	ON	ON	OFF	OFF	ON	0x19
CHROMA Tx 40	OFF	OFF	ON	OFF	OFF	OFF	OFF	OFF	0x20
CRYSTAL Tx 40	OFF	OFF	ON	OFF	OFF	OFF	OFF	ON	0x21
MAGNUM XL 54	OFF	OFF	ON	OFF	OFF	OFF	ON	OFF	0x22

	SW 1	SW 2	SW 3	SW 4	SW 5	SW 6	SW 7	SW 8	HE X
COUGAR Tx 36	OFF	OFF	ON	OFF	OFF	OFF	ON	ON	0x23
CHAMELEON Tx 36	OFF	OFF	ON	OFF	OFF	ON	ON	OFF	0x26
PREMIER Tx 36	OFF	OFF	ON	OFF	OFF	ON	ON	ON	0x27

An undefined switch setting may cause the 'Invalid Scanner ID' Error Code to be displayed on the Operator Panel, see Section 7.4, page 152.

CAUTION:

The Scanner ID Switch setting is stored in the Flash Memory on the SUC-Board. Every time the scanner is switched ON, it reads the switch setting and if it is different from the stored value, the new setting will be stored and all other stored scanner parameters (including Stitching, Basic Calibration and Color Calibration) will be cleared to default values.

This means that the scanner must be calibrated using Scanner Maintenance afterwards to restore the actual values.

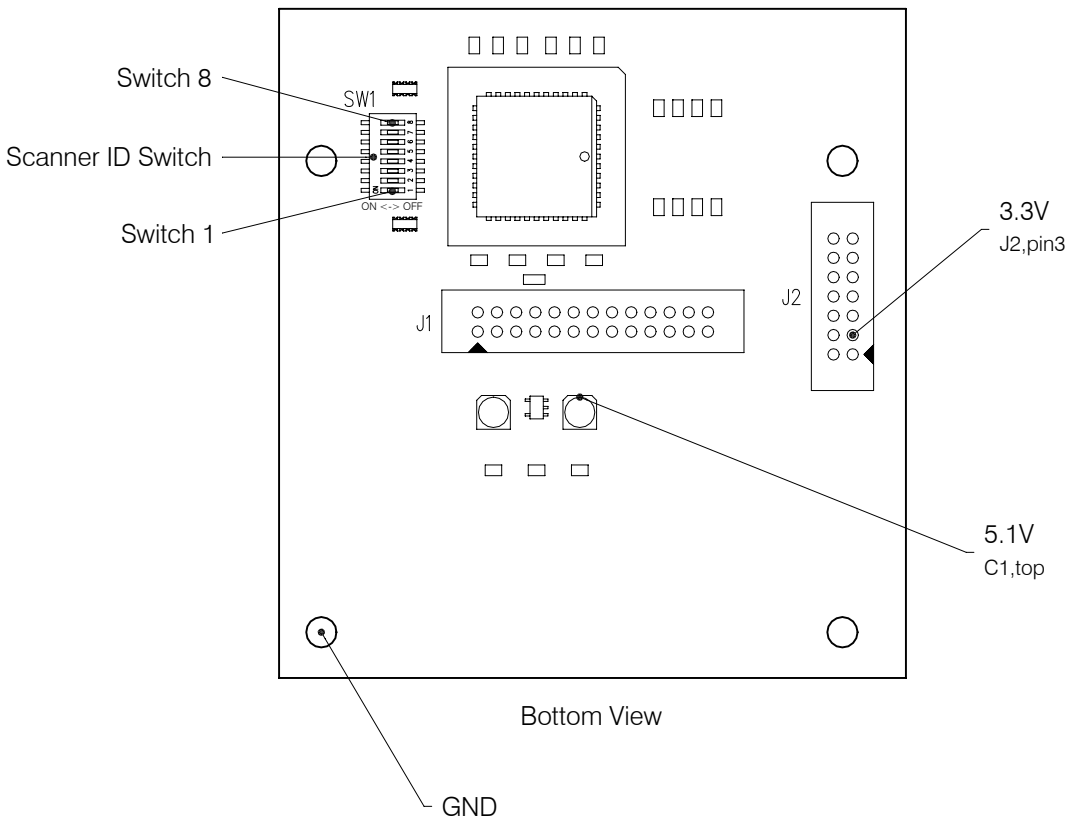
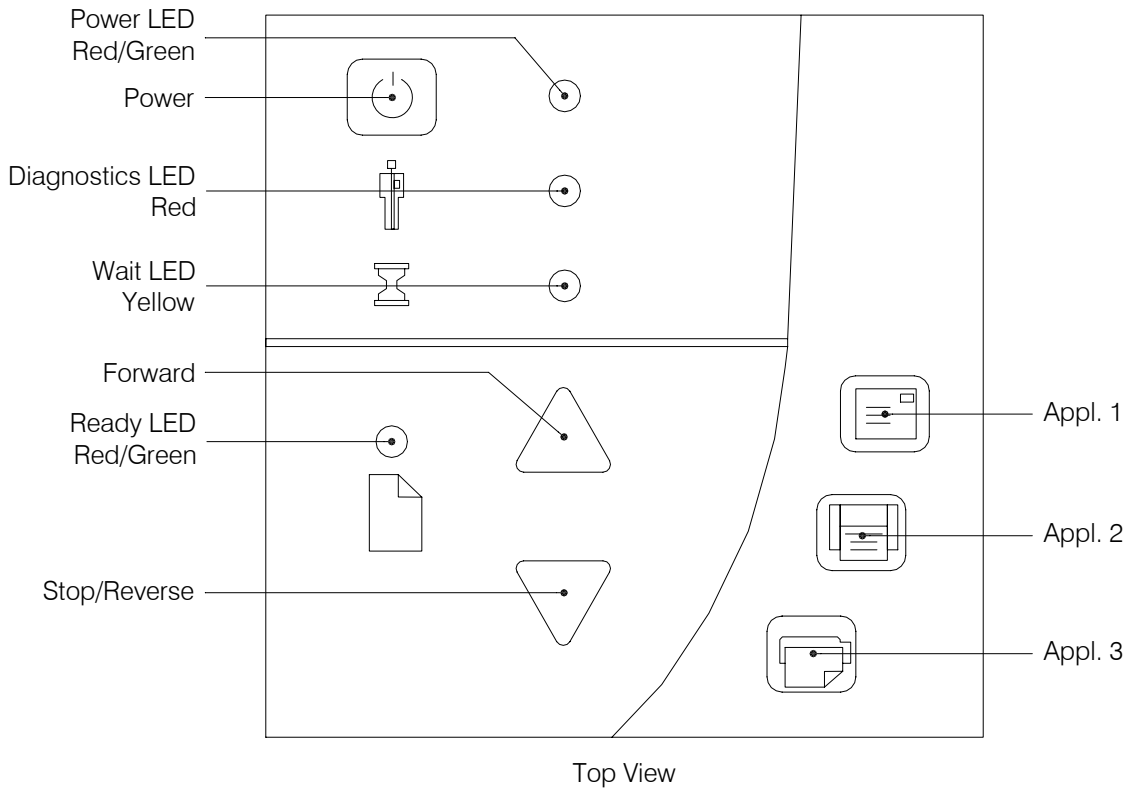

Fig. 3-14 SKDA Component Layout

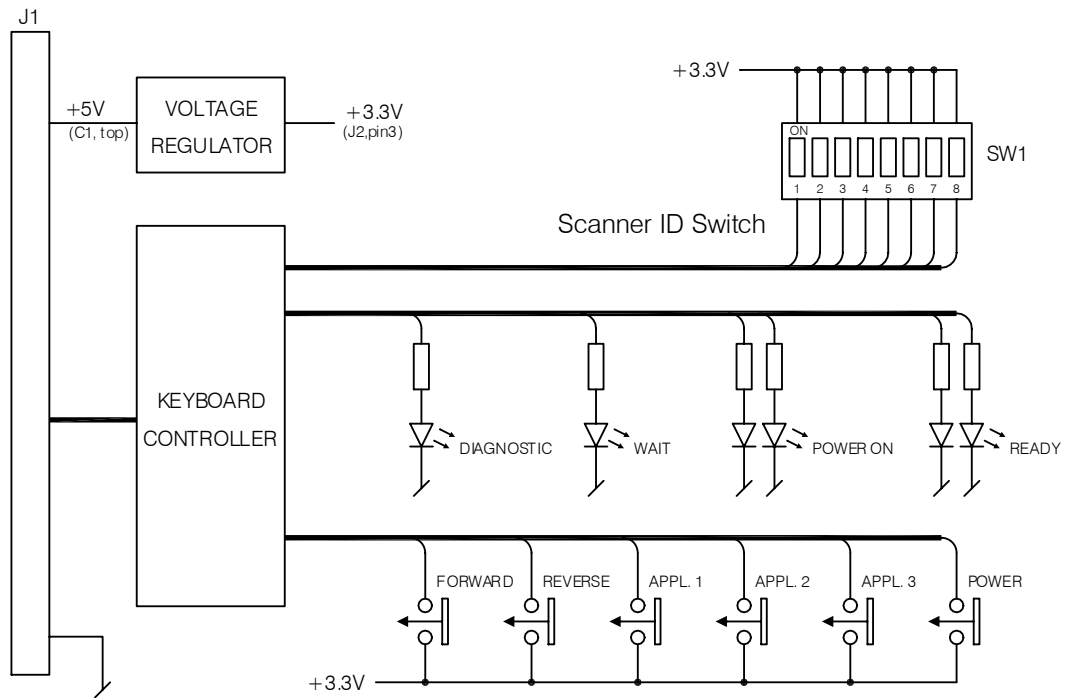
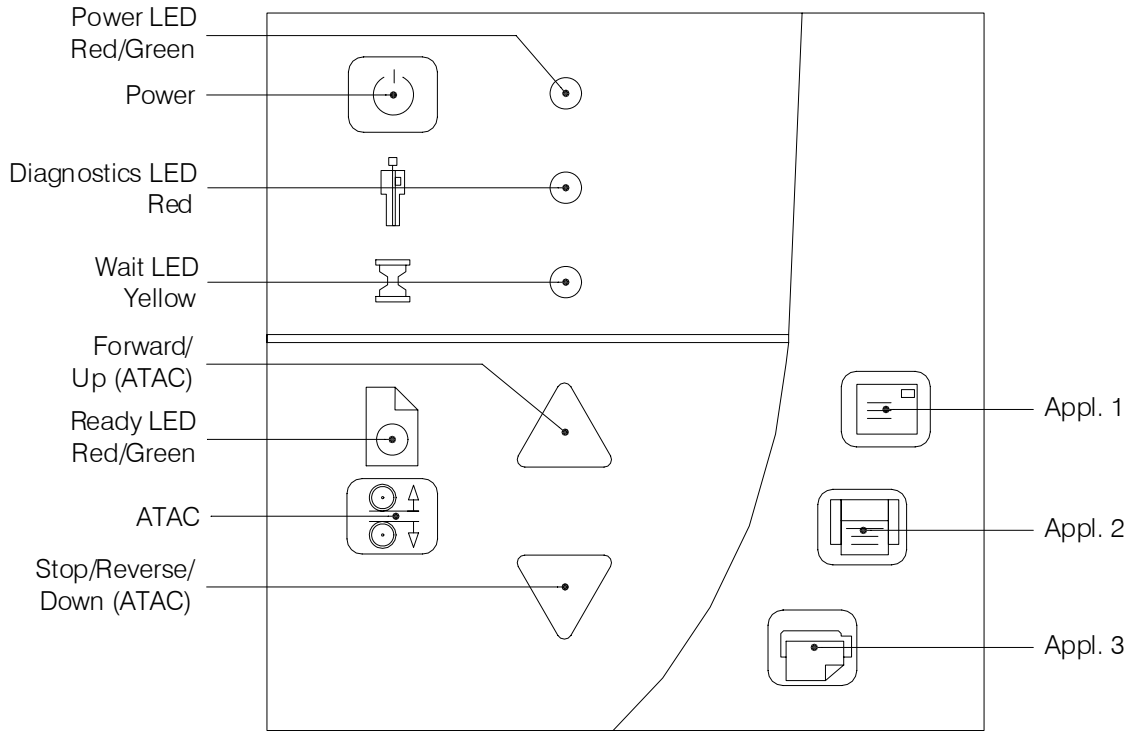
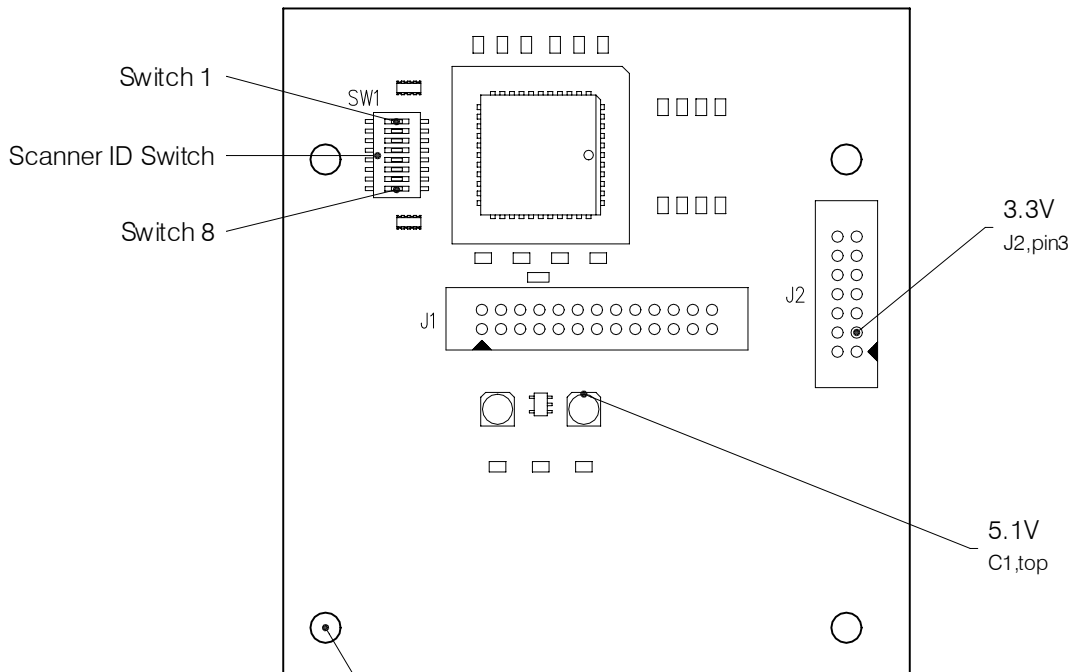

Fig. 3-15 SKDA Block Diagram



Top View



Bottom View

Fig. 3-16 SKDF Component Layout

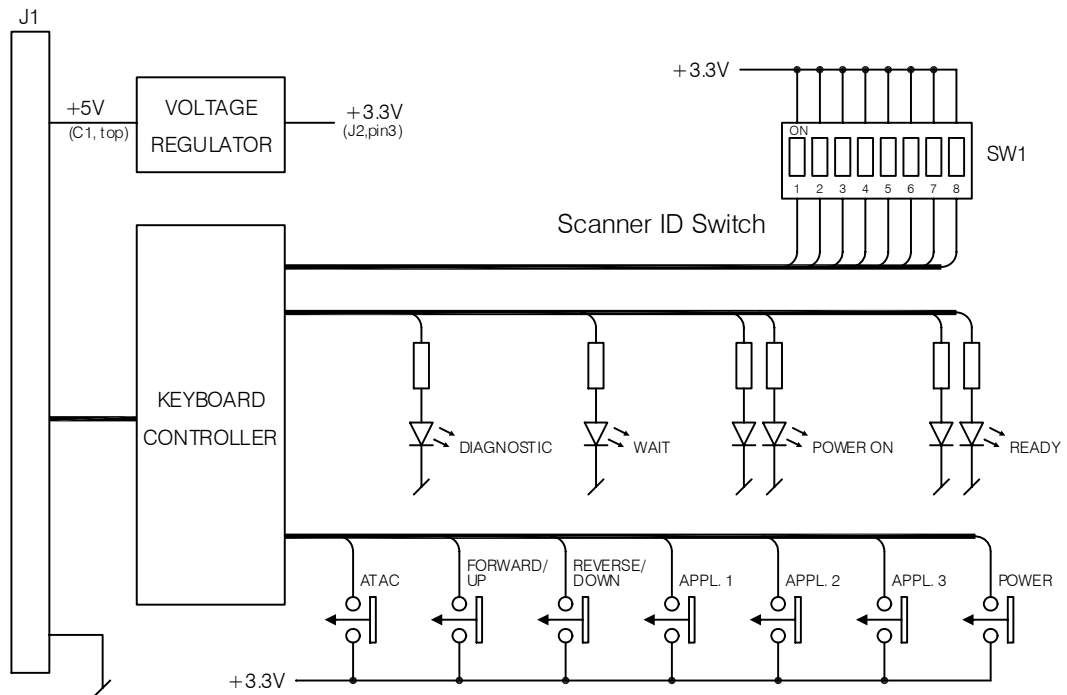

Fig. 3-17 SKDF Block Diagram

3.11 Check of Smart Card Reader, SCR

All test points referred to below are shown in Fig. 3-18, page 62.

All DC voltages are measured relative to test point GND (DIP Switch, right-side pins).

SCR Block Diagram is shown in Fig. 3-19, page 63.

3.11.1 DC Voltages

Ref. on Fig. 3-18	DC Voltage
R2, top	+5.1 V +0.1/-0.2 V

3.11.2 Functional Test

SCANtest 6: Test 1, Scanner Model (Smart Card)

SCSI ID (N.A. for CHAMELEON 25, 36, PREMIER 36)

3.11.3 Markings

COUGAR 25	SCRAdd
COUGAR 36	SCRAdd
CHAMELEON 25	SCRAdd
CHAMELEON 36	SCRAdd
CHAMELEON PREMIER 36	SCRAdd
CHROMA Tx 40	SCRAdd
CRYSTAL Tx 40	SCRAdd
MAGNUM XL 54	SCRAdd
COUGAR Tx 36	SCRAdd
CHAMELEON Tx 36	SCRAdd
PREMIER Tx 36	SCRAdd
where dd = board revision number.	

3.11.4 DIP Switch Setting

SCSI related switch settings (SW No. 1, 2, 3, 4, and 5) do not apply for CHAMELEON.

Default DIP Switch Setting:

Switch No:	1	2	3	4	5	6	7	8
SCSI ID 2	ON	OFF	ON	ON	OFF	OFF	OFF	OFF

SCSI ID, Terminator, and Communication Mode Selection:

Switch No:	1	2	3	4	5	6	7	8
SCSI ID 0	ON	ON	ON	X	X	X	X	X
SCSI ID 1	OFF	ON	ON	X	X	X	X	X
SCSI ID 2	ON	OFF	ON	X	X	X	X	X
SCSI ID 3	OFF	OFF	ON	X	X	X	X	X
SCSI ID 4	ON	ON	OFF	X	X	X	X	X
SCSI ID 5	OFF	ON	OFF	X	X	X	X	X
SCSI ID 6	ON	OFF	OFF	X	X	X	X	X
SCSI ID 7	OFF	OFF	OFF	X	X	X	X	X

Switch No:	1	2	3	4	5	6	7	8
<i>SCAN-SCSI Termination</i> Intern, active: Extern:				ON OFF				
<i>SCAN-SCSI Transfer mode</i> Asynchronous: Synchronous:					ON OFF			
<i>Not used</i> (Don't care)						(OFF)		

Troubleshooting and Test Switches:

Switch No:	1	2	3	4	5	6	7	8
<i>Boot start-up</i> Forced: Normal:							ON OFF	
<i>Factory testing</i> Self-test: Normal:								ON OFF

- SW1-3: SCSI ID
- SW4: Selects internal, active SCSI termination or external, passive SCSI termination, normally set to ON.
- SW5: If the SCSI communication fails try to run 'Asynchronous'. This mode is intended for debugging, and SW5 should normally be set to OFF.
- SW6: Not used.
- SW7: If download fails, try to set SW7 to ON. For normal operation SW7 must be set to OFF.
- SW8: Reserved for factory testing and **must** be set to OFF.

NB! The switches are read at power-on only, and the scanner must be switched OFF and back ON for a changed switch setting to become effective.

3.11.5 Signal LED on the SCR-Board

The signal LED on the SCR-Board turns ON when the Smart Card is inserted. It only signals, that a Smart Card has been inserted, it does not show whether the card is valid or not.

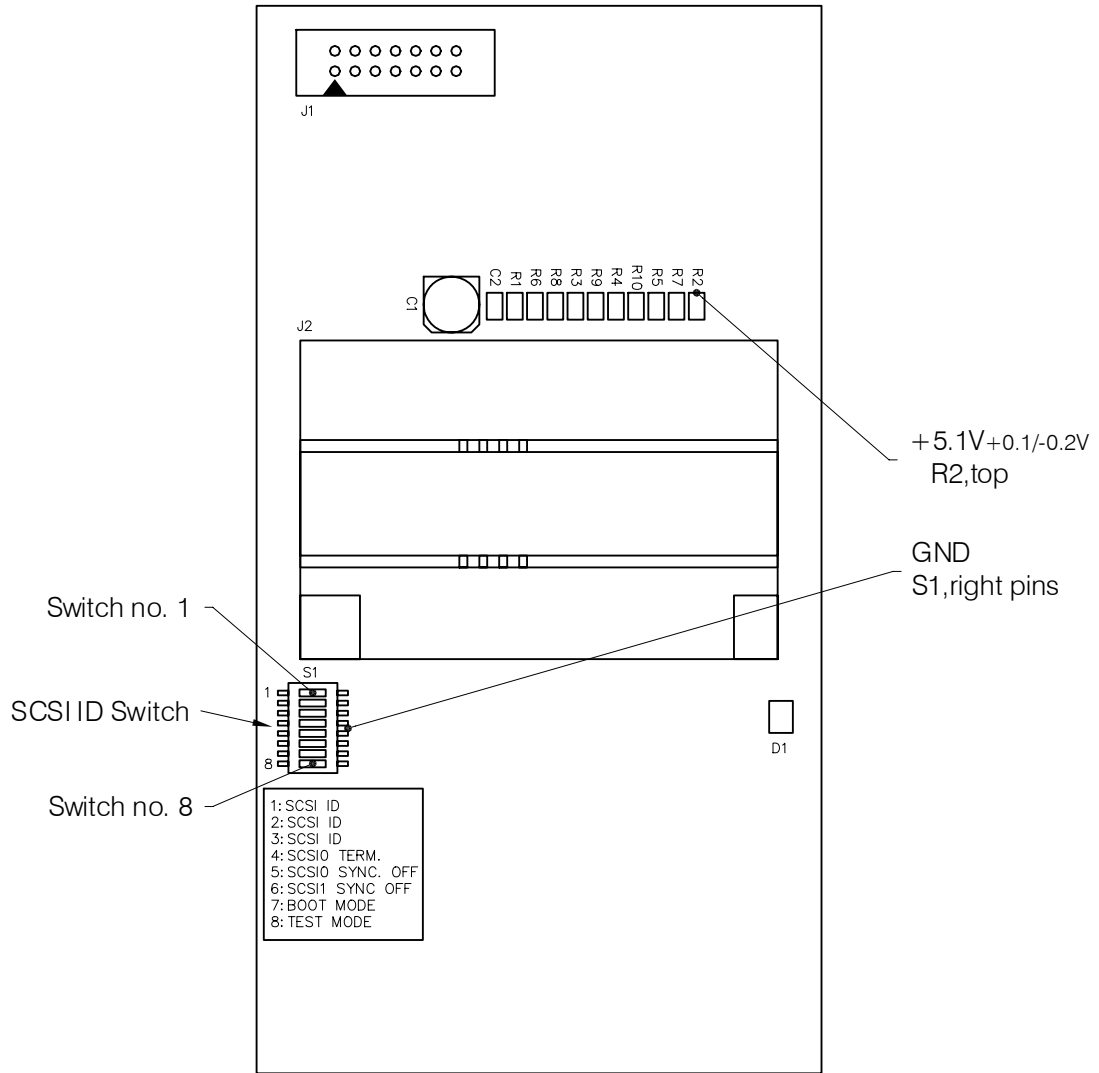

Fig. 3-18 SCR Component Layout

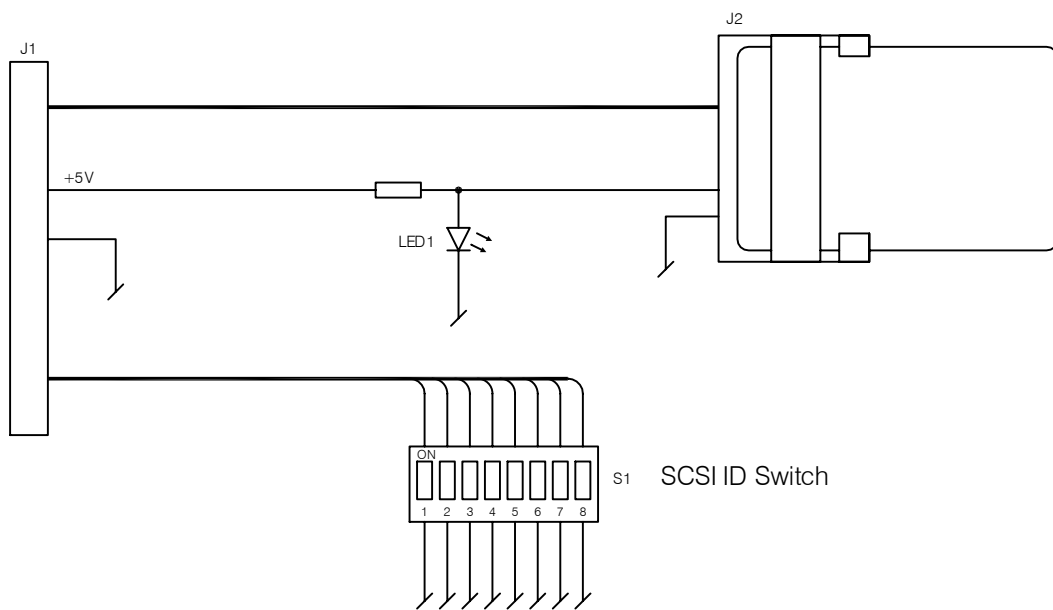

Fig. 3-19 SCR Block Diagram

3.12 Check of Lamp Sensor Board, OSB

The OSB Component Layout is shown in Fig. 3-20, page 65.

3.12.1 Functional Test

SCANtest 6: Test 5, Lamp Test

Connect a voltmeter to TP7 on the LME-Board

Turn Lamp OFF / ON

The voltage on TP7 should change to approx. 3.7 V to 4.0 V when the lamp is turned OFF. When the lamp is ON the voltage should be as described in Section 3.4.2, page 30.

3.12.2 Markings

COUGAR 25	OBSC-d.d
COUGAR 36	OBSC-d.d
CHAMELEON 25	OBSC-d.d
CHAMELEON 36	OBSC-d.d
CHAMELEON PREMIER 36	OBSC-d.d
CHROMA Tx 40	OBSC-d.d
CRYSTAL Tx 40	OBSC-d.d
MAGNUM XL 54	OSBC-d.d
COUGAR Tx 36	OBSC-d.d
CHAMELEON Tx 36	OBSC-d.d
PREMIER Tx 36	OBSC-d.d
where dd = board revision number.	

3.13 Check of Optointerrupter Board, OIBA

The OIB Component Layout is shown in Fig. 3-21, page 65.

3.13.1 Functional Test

SCANtest 6: Test 4, Original-Sensor Test

3.13.2 Markings

COUGAR 25	OIBA-d.d
COUGAR 36	OIBA-d.d
CHAMELEON 25	OIBA-d.d
CHAMELEON 36	OIBA-d.d
CHAMELEON PREMIER 36	OIBA-d.d
CHROMA Tx 40	OIBA-d.d
CRYSTAL Tx 40	OIBA-d.d
MAGNUM XL 54	OIBA-d.d
COUGAR Tx 36	OIBA-d.d
CHAMELEON Tx 36	OIBA-d.d
PREMIER Tx 36	OIBA-d.d
where dd = board revision number.	

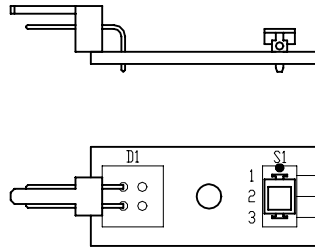

Fig. 3-20 OSB Component Layout

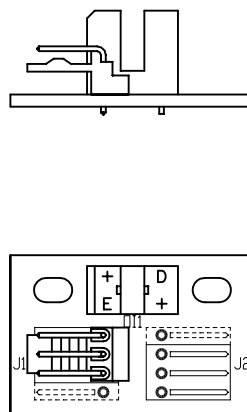

Fig. 3-21 OIBA Component Layout

3.14 Check of ATAC Motor Driver Board, MDA

All test points referred to below are shown in Fig. 3-22, page 67.

All voltages are measured relative to test points TP1 (GND).

MDA Block Diagram is shown in Fig. 3-23, page 68.

3.14.1 DC Voltages

Ref. on Fig. 3-12	DC Voltage	Remarks
C2, left	+12.0 V +1/-0 V	SUC, 12V_CAM
C4, top	+5.3 V +0/-0.2 V	SUC, 5V_CAM
TP2	+5.0 V \pm 0.15 V	Regulator on MDA
TP4	+3.3 V \pm 0.1 V	Regulator on MDA

3.14.2 Adjustments

No adjustments.

3.14.3 Functional Test

SCANtest 6, Test 28, Original Sensor Test

See Section 3.15.3, page 70

3.14.4 Markings

MAGNUM XL 54	MDABdd
where dd = board revision number.	

3.14.5 Jumper Settings

No jumpers.

3.14.6 Hints

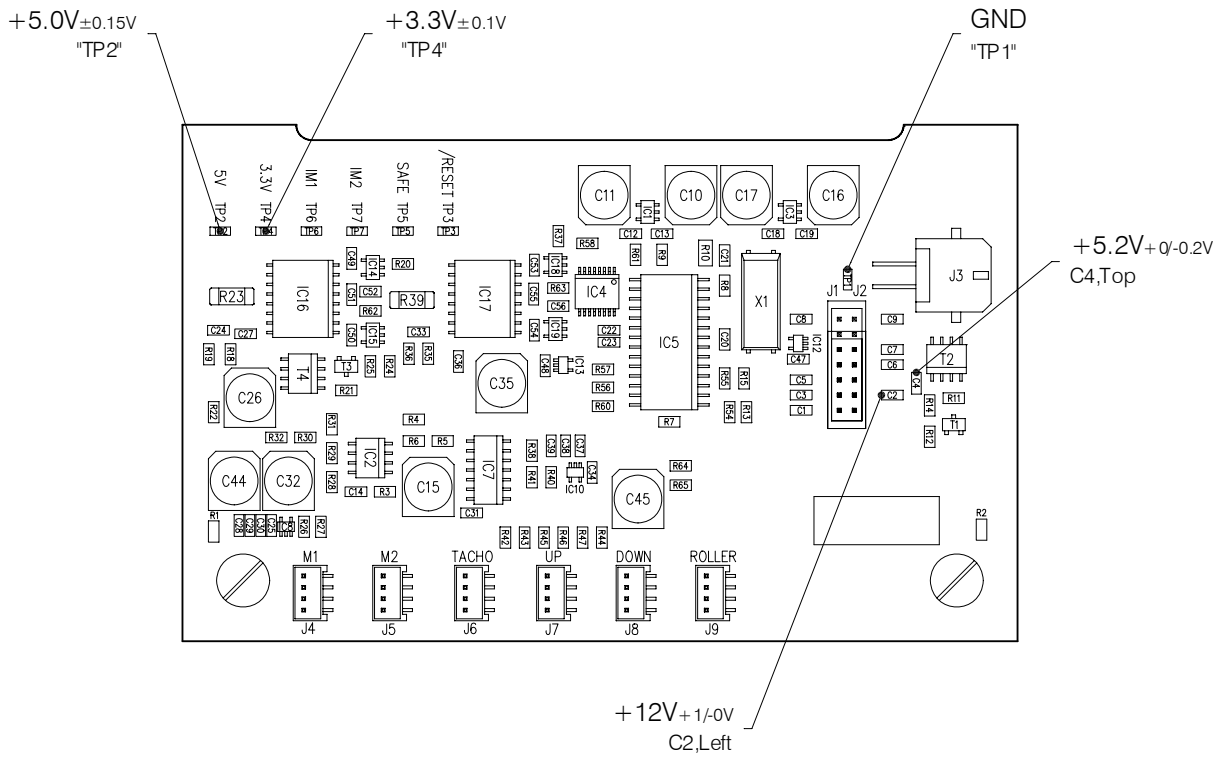

Fig. 3-22 MDA Component Layout

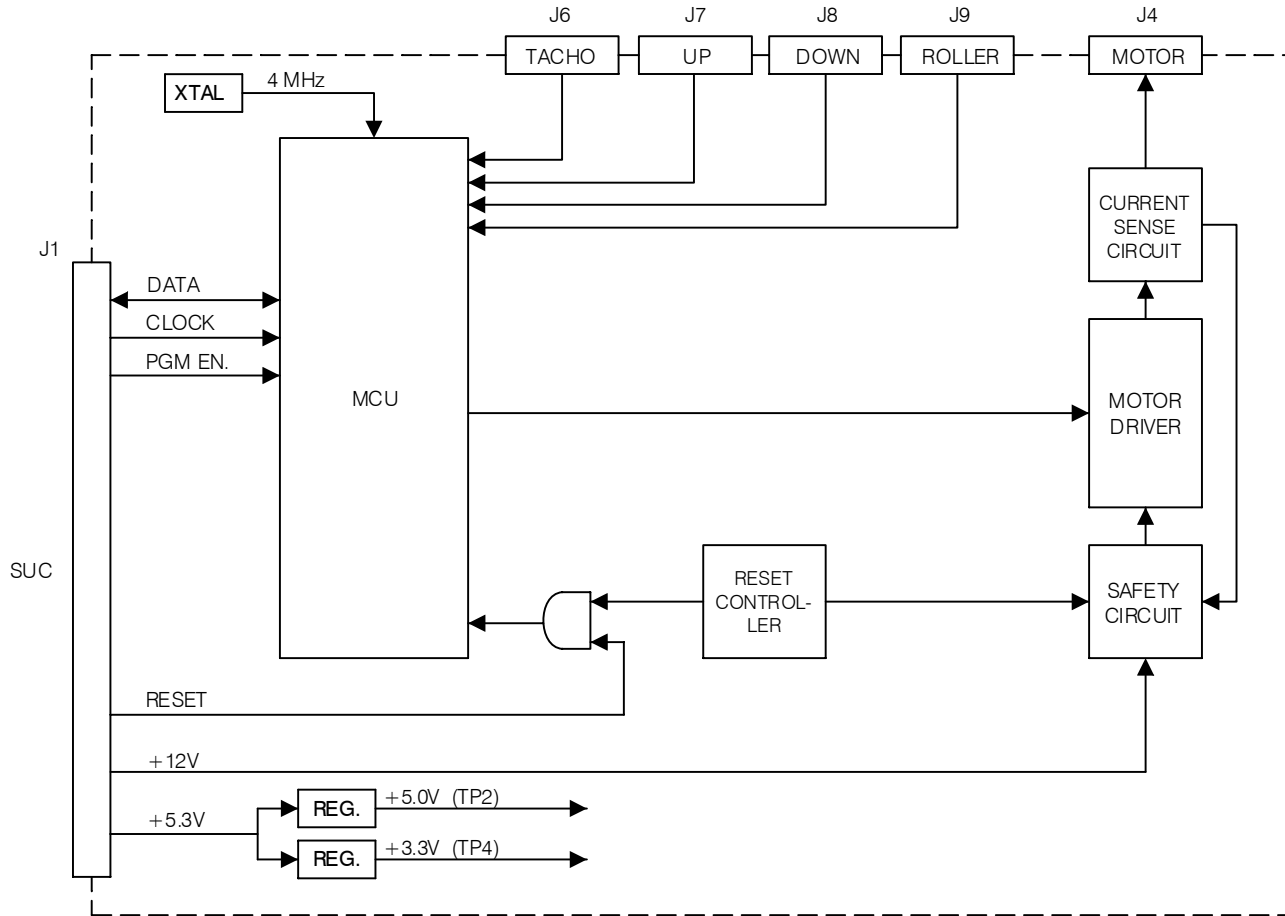

Fig. 3-23 MDA Block Diagram

3.15 Check and Adjustment of Original Guide Sensors (ATAC)

The Original Guide Sensors are located under the Top Profile of the Original Guide. To get access to the sensors:

- Remove the Ruler from the Original Guide.
- Remove the 4 fixing screws behind the Ruler.
- Remove the Top Profile from the Original Guide.

Notes:

1) All sensors are click-mounted on brackets, the position of the ATAC sensor bracket is secured by means of two fixing screws. To make the sensor adjustment easier, the left fixing screw goes through round hole and the right through an oblong hole.

The bracket for the motor (tacho) sensor is secured by only one fixing screw

2) For safety reasons, the current of the Elevation Motor is constantly monitored, and if the currents exceeds a predetermined value, the drive circuit will be switched OFF and the motor stops and can no longer be controlled from the Operator Panel.

To reset the OFF condition, the power must be removed from the MDA Board, either by disconnection of the power cable (connector J1 on MDA) or by switching the scanner OFF/ON.

3) When moving the Original Guide towards "top position", the motor should be stopped before the spindle-nut reach the left end of the spindle, allow for a spacing of about 1-2 mm as shown in Fig. 3-26, page 74. If the UP Key is pressed until the spindle-nut hits the end-stop of the spindle, the motor will be switched OFF by the current limit circuit and can no longer be controlled from the Operator Panel, see note 2).

3.15.1 Adjustment of Roller Sensor

See Fig. 3-24, page 72 and Fig. 3-27, page 75.

Start SCANtest 6

Select Test28, Original Guide Sensor Test

Press UP Key to move Original Guide up at the least until the Ready LED turns OFF.

Insert the 1.5 mm foot of the two Adjustment Tools under the roller shaft on both sides of the Roller Sensor, and adjust the position of the Roller Sensor just to turn the green Ready LED ON.

Insert the 1 mm foot of the two Adjustment Tools under the roller shaft on both sides of the Roller Sensor, and check that the green Ready LED is OFF.

3.15.2 Adjustment of Top Position Sensor

See Fig. 3-25, page 73 and Fig. 3-28, page 75.

Close and lock the Original Guide.

Start SCANtest 6

Select Test 28, Original Guide Sensor Test

Loosen the fixing screws of the sensor bracket, move the sensor to its uppermost position and fasten the fixing screws.

Press UP Key to move Original Guide to Top Position, observe note 3) above.

Open the Original Guide.

Orientate the two adjustment guides for 16 mm spacing and place the guides under the Original Guide at either end of the scan area.

The surface marked "16" must be facing the White Background Plate.

The cut out must be centered over the light aperture of the glass plate not to damage the White Background Plate when the Original Guide is moved down against the adjustment guide.

Close the Original Guide and make sure that both Release Handles lock.

Press the Down Key to move the Original Guide down until it automatically stops against the adjustment guides.

If the Down Key is pressed after the Original Guide has stopped, the MDA Board ends up in the OFF condition described in note 2) above.

Adjust the position of the Top Position sensor just to turn the green Power LED ON.

Open the Original Guide.

Orientate the two adjustment guides for 15.5 mm spacing and place the guides under the Original Guide at either end of the scan area.

The surface marked "15.5" must be facing the White Background Plate.

The cut out must be centered over the light aperture of the glass plate not to damage the White Background Plate when the Original Guide is moved down against the adjustment guide.

Close the Original Guide and make sure that both Release Handles lock.

Press the Down Key to move the Original Guide down until it automatically stops against the adjustment guides.

Check that the Power Led has now been turned OFF.

3.15.3 Check of ATAC Position Sensors

Start SCANtest 6

Select Test 28, Original Guide Sensor Test

Press the UP Key to move Original Guide to Top Position and observe that:

Power LED turns green (Top Position Sensor activated)
Wait LED is OFF
Ready LED is OFF

Move the Original Guide down by pressing the Down Key and observe that the LEDs go OFF/ON in following sequence:

Power LED turns OFF
Wait LED turns yellow (Down Position Sensor* activated)
Ready LED turns green (Roller sensor activated)

*) The Down Position Sensor cannot be adjusted.

Adjustment Tools

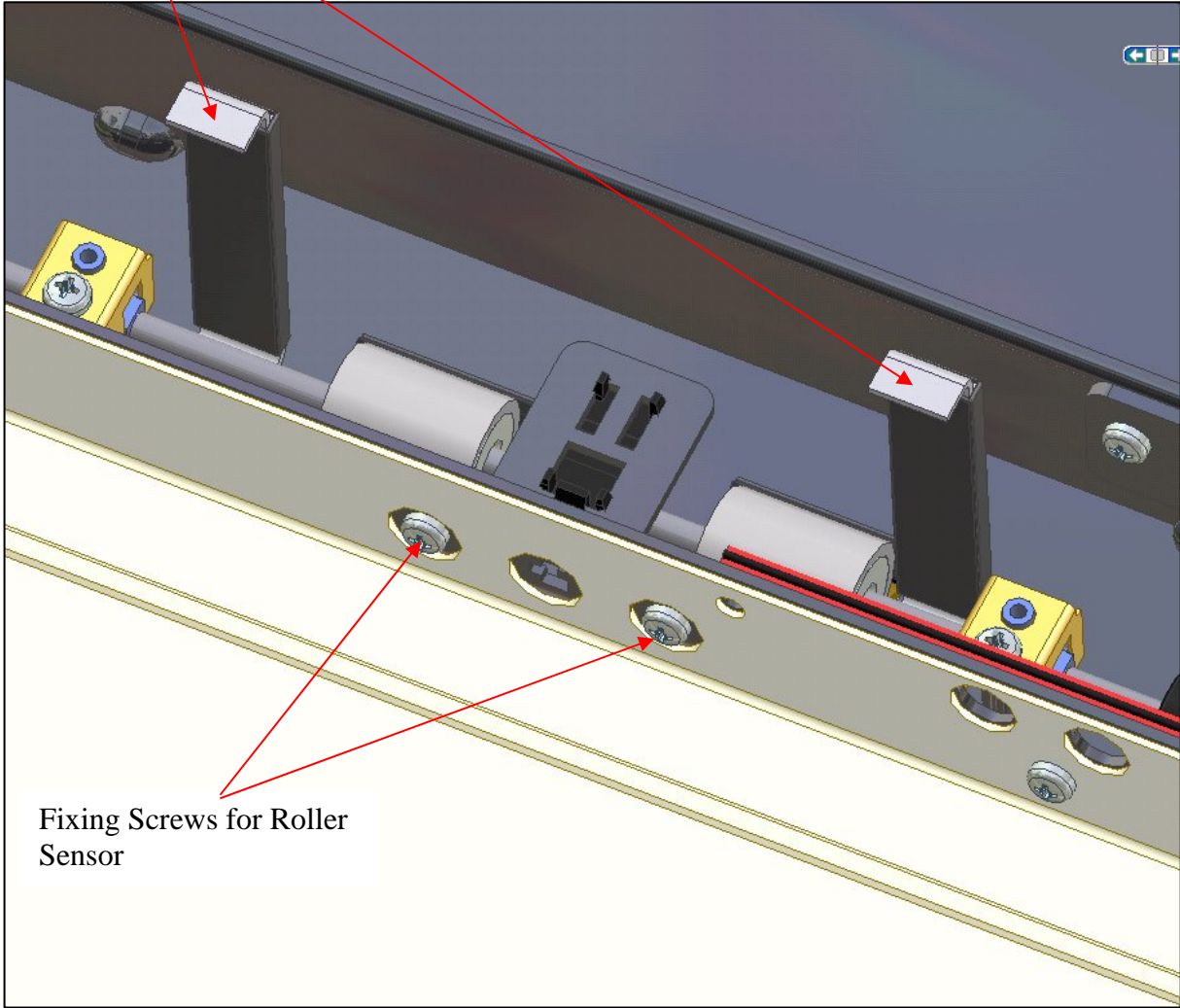

Fixing Screws for Roller Sensor

Fig. 3-24 Adjustment of Roller Sensor

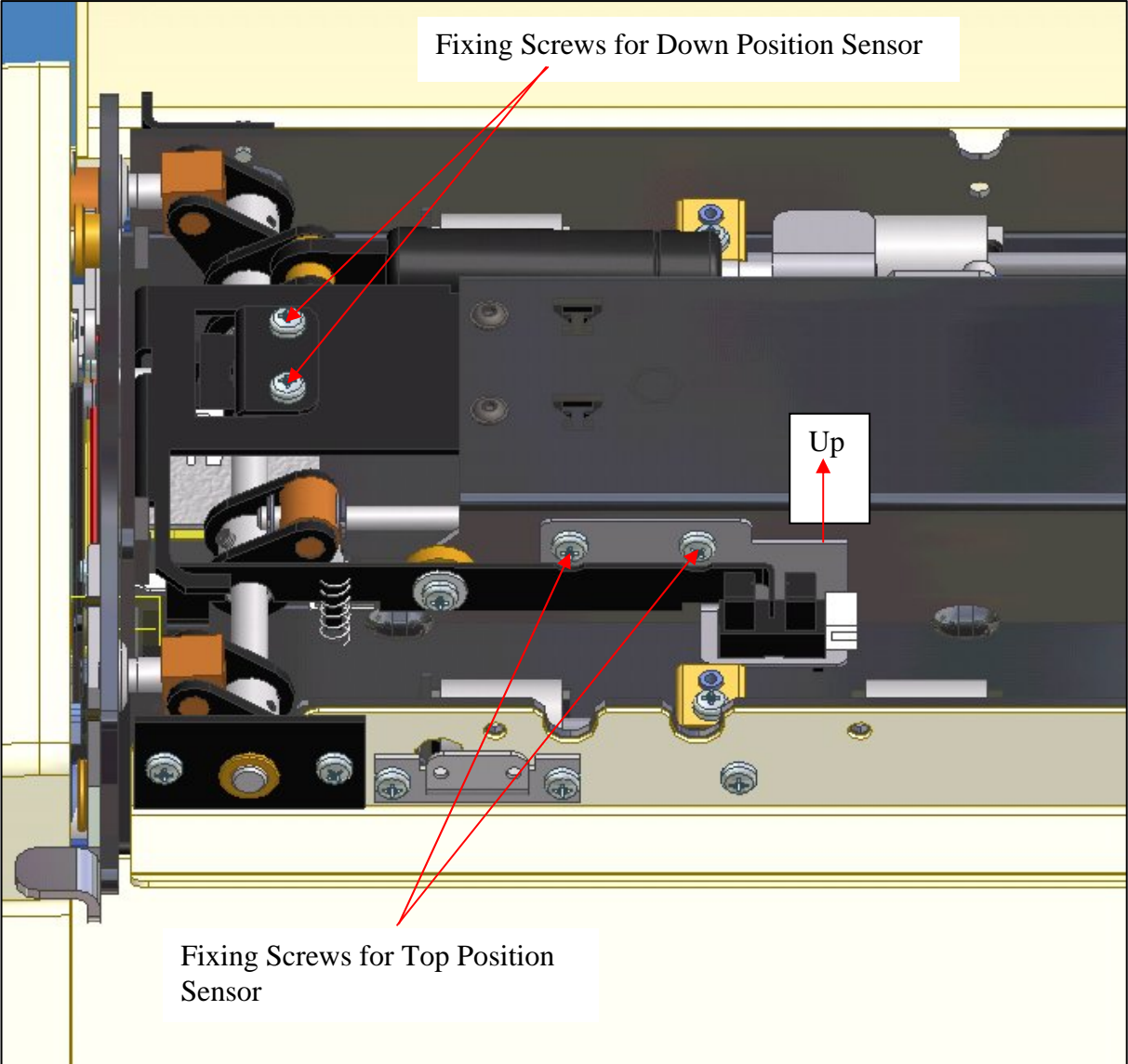

Fig. 3-25 Adjustment of Top Position Sensor

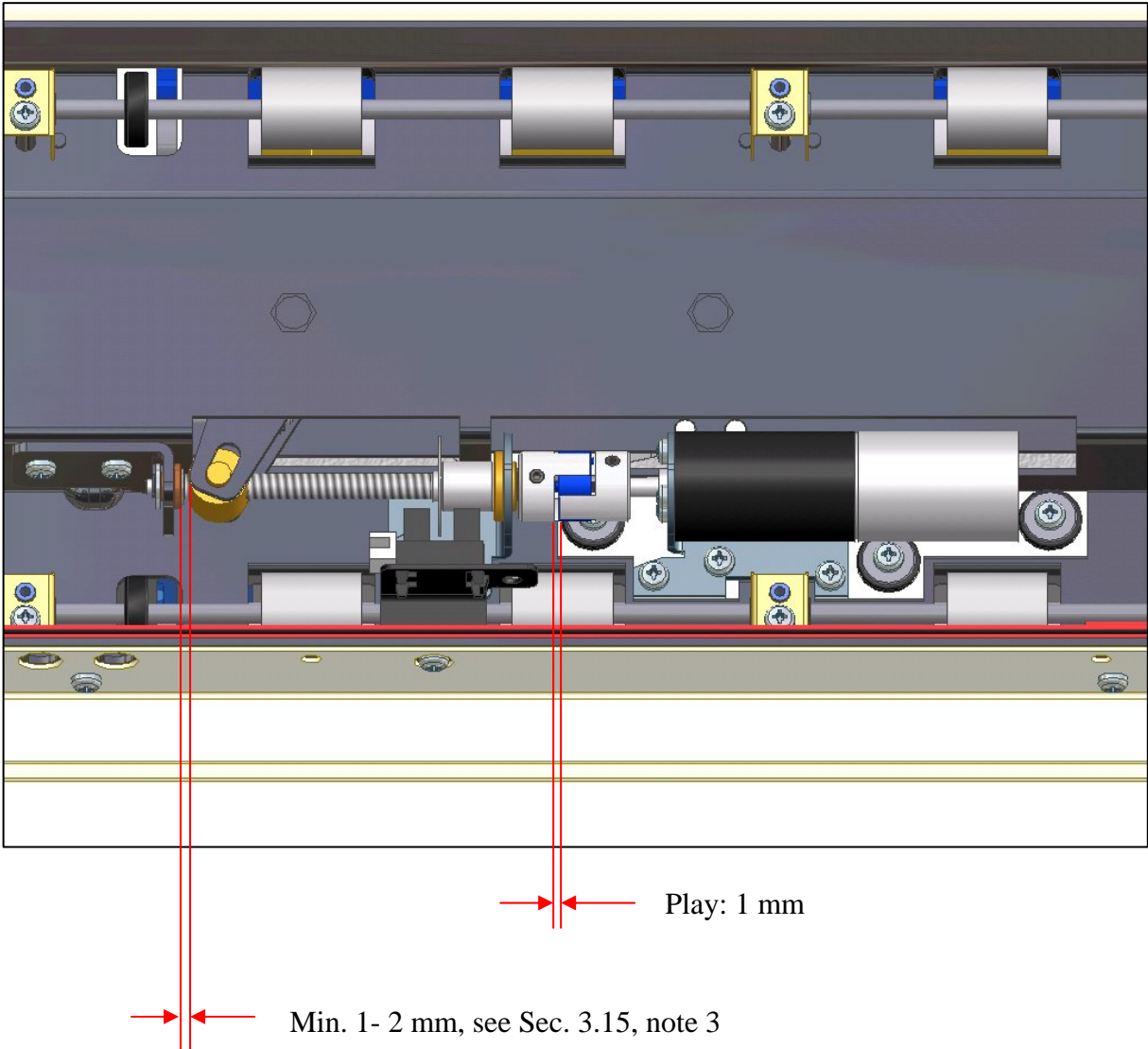

Fig. 3-26 Elevation Motor and Spindle

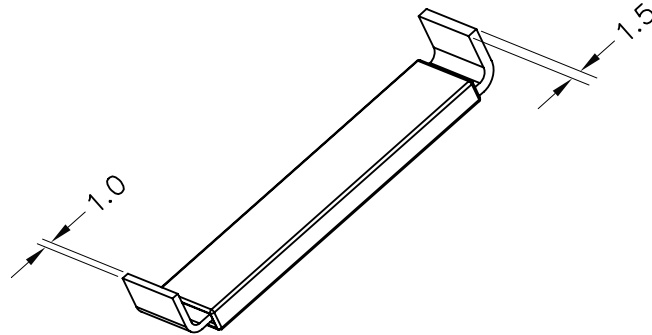

Fig. 3-27 Adjustment Tool for Roller Sensor

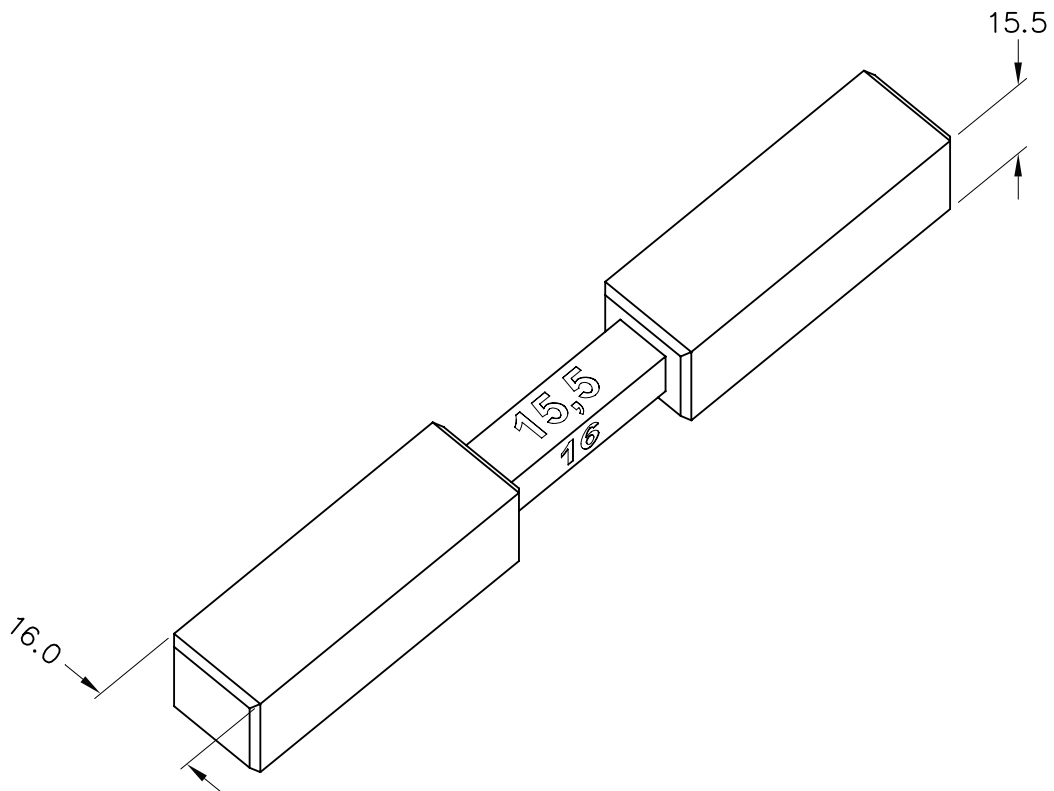

Fig. 3-28 Adjustment Tool for Top Position Sensor

3.16 Adjustment of Original Sensors

The Original Sensors are located under the End Cover at the Operator Panel end of the scanner.

3.16.1 Adjustment of Switch Point

See Fig. 3-29, page 77.

To adjust the Original Sensors:

- Remove the Guard Plate over the Optical Interrupter Board
- Loosen the screws that hold the bracket with the Optical Interrupter Board

Adjust the switch point by shifting the OIB-Board up/down until the peak of the curved Original Sensor Actuator is:

3.9 mm +/- 0.5 mm above the top of the Feed Rollers

Note that the Shutter must rest on top of the one leg of the Optical Interrupter.

All Original Sensor Actuators must be within the above tolerance.

Check:

- That the Original Sensor Shutter moves freely in the gap of the opto-interrupter, when the Sensor Actuator is activated.
- That the Entry Original Sensor Shutter does not touch the press nut for the Glass Plate bearing, when the Sensor Actuator is activated.
- That the Torsion Springs are correctly mounted.

3.16.2 Functional Test

SCANtest 6: Test 4, Original Sensor Test

3.16.3 Hints

The Exit Sensor determines the Start of Scan position of the original. The original is first moved forward to activate the Exit Sensor and after that moved a pre-defined distance backwards to the Start of Scan position.

End of Scan is determined by a pre-defined distance from the position where the original releases the Entry Sensor.

The points of Start of Scan and End of Scan may be offset from WIDEimage (Scanner Setup / Media Offset).

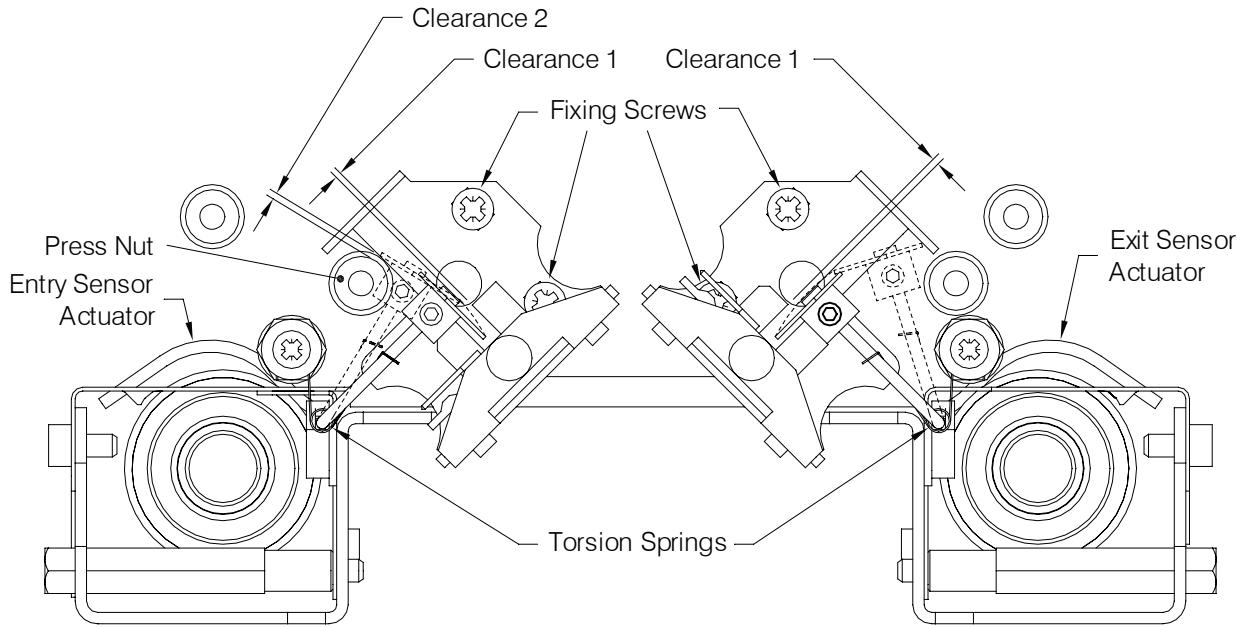

Clearance 1: Make sure that the shutter plates do not touch the legs of the optointerrupter when moving (clearance >0.5 mm)

Clearance 2: Make sure that the shutter plates do not touch the press-nut when moving (clearance > 0.5mm)

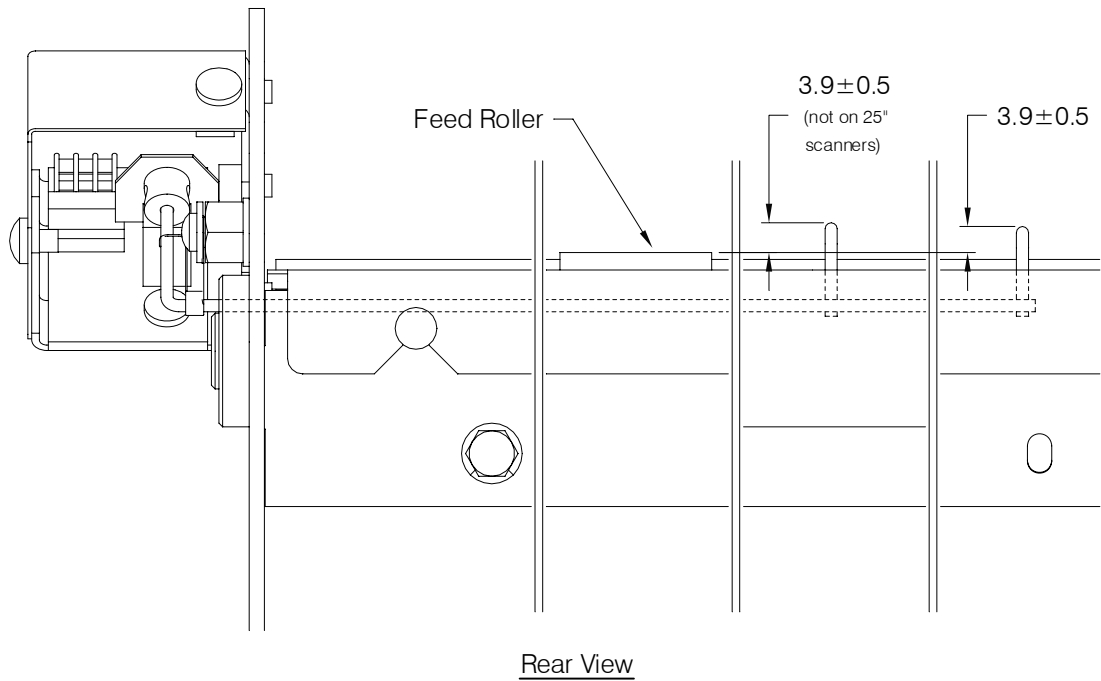

Fig. 3-29 Adjustment of Original-Sensors

3.17 Check of Media Thickness Detector (not applicable to MAGNUM XL 54)

The two Media Thickness Detectors are located under the End Covers and are activated by the left and right Media Thickness Adjustment Sliders when the Original Guide Plate is full down in the Normal position (original thickness less than 2 mm).

3.17.1 Functional Test

SCANtest 6: Test 4, Original Sensor and Media Thickness Detector

While Test 4 runs, slide the Media Thickness Adjustment Sliders, one at the time, out and in to turn the Wait LED on the Operator Panel ON/OFF.

4. CCD-Cameras

The adjustment procedures presented in this chapter cover all adjustments needed for replacing the complete CCD-camera.

It will hardly ever be necessary to replace mechanical parts such as Lens, Camera Housing, etc., and in most cases, the only adjustments necessary after replacement of the CBE/CBF-Board are:

- Check Scan-Width. If it is within the limits given in Section 4.2.5, page 99, then Focus will also be OK.
- CCD-Centering, Section 4.2.6 page 109
- Vertical Positioning, Section 4.2.7, page 110
- Run Scanner Maintenance, Section 6.1.7, page 142 to do
Vertical Alignment and Stitching
Basic and Color Calibration

These adjustments can be made without loosening the Camera Fixing Screws and without loosening the Focus Lock Ring / Lock Screw.

4.1 Description of CCD-Cameras

See:

- Fig. 4-1 Focus Lock Mechanism, page 82
- Fig. 4-2 CCD-Camera, Side View, page 83
- Fig. 4-3 CCD-Camera, Top View, page 84

The CCD-Camera basically consist of:

- Lens
- Lens Adapter
- Camera Housing
- Camera Back-Plate
- CCD Mounting Plate
- CBE/CBF-Camera Board
- Camera Base Plate
- Camera Motor, on Adjustable Cameras only

The parts of the CCD-Camera are mounted on a Camera Base Plate, and the complete CCD-Camera is mounted on a Mounting Platform, which is welded to the scanner chassis. The Camera is positioned with the optical axis perpendicular to the scan-area by means of two guide pins extending from the bottom of the Base Plate down into two slots in the Mounting Platform.

When the three Camera Fixing Screws are loosened for Camera Adjustment, two tension springs pull the Camera Base Plate down against the Mounting Platform. Another spring pulls the CCD-Camera in forward direction to keep the Scan Width Adjustment Screw in contact with the scanner chassis, and to the left to align the guide pins with the left edge of the slots in the Mounting Platform.

The Camera Housing can be tilted slightly up and down to position the scanline in the “vertical” direction by turning the Vertical Positioning Wheel. All cameras but one have a small Camera Motor, which via the Vertical Alignment Arm, may turn the Vertical Positioning Wheel.

The Camera Motor is controlled by Scanner Maintenance or SCANtest 6 software for automatic Vertical Alignment of the cameras.

Focus

The CCD-Camera is focused by loosening the Focus Lock Ring / Lock Screw and turning the Lens Adapter to get the maximal amplitude of the image of the Focus Pattern.

The Lens itself is mounted in the Lens Adapter, and three Allen screws secure its position in the adapter. When these screws are loosened, the lens can be rotated to have the dot on the lens pointing upwards. This is the “best position” as determined by the lens manufacturer.

This “best position” is not critical, and when doing field adjustments it will hardly ever be necessary to change the factory set position of the Lens.

On early models of COUGAR and CHAMELEON the Lens Adapter is secured by means of a Focus Lock Ring.

On later models, slots in the Camera Housing allow the tube of the Camera Housing to be tightened around the Lens Adapter by means of a Focus Lock Screw, see Fig. 4-1, page 82.

The slots are covered by a flexible Covering Tape to prevent stray light from entering the camera.

Scan-Width

The Scan-Width depends on the distance between the CCD-Camera and the scan-area. It can be adjusted by loosening the three Camera Fixing Screws and turning the Scan Width Adjustment Screw to slide the CCD-Camera back and forth to get the required number of Scan-Width Units within the field of vision, see Scan-Width Pattern, Fig. 4-45, page 122.

The scaling accuracy of the scanner depends directly on the accuracy of the Scan-Width adjustment.

Vertical Positioning of CCD-Cameras

To set the basic Vertical Position of all cameras, the lock screw of the Vertical Alignment Arm on the adjustable cameras are loosened and the Vertical Positioning Wheel adjusted to get 8 Black Lines of the Vertical Position Pattern, see Fig. 4-45, page 122.

The Vertical Alignment Arm should now be positioned in parallel with the Back Plate of the camera. The Vertical Alignment Arm may be turned by the Camera Motor using:

SCANtest 6, Test 9, Camera Motor	
Select	Camera
Press	Forward (1), to move the arm away from the Back Plate.
Press	Reverse (2), to move the arm towards the Back Plate.

Or, alternatively, the Vertical Alignment Arm may be turned by dismantling the Camera Motor and turning the pulley of the spindle by hand, see Fig. 4-44, page 121.

Tighten the lock screw when the Vertical Alignment Arm is parallel with the Back Plate.

The final positioning of the scanline within the scan-area is done by shifting the CCD Mounting Plate relative to the Camera Housing.

Fig. 4-4, page 85 shows the relation between the patterns on the Optical Adjustment Pattern and the waveforms seen on the screen of SCANtest 6, Test 9 during Camera Adjustment.

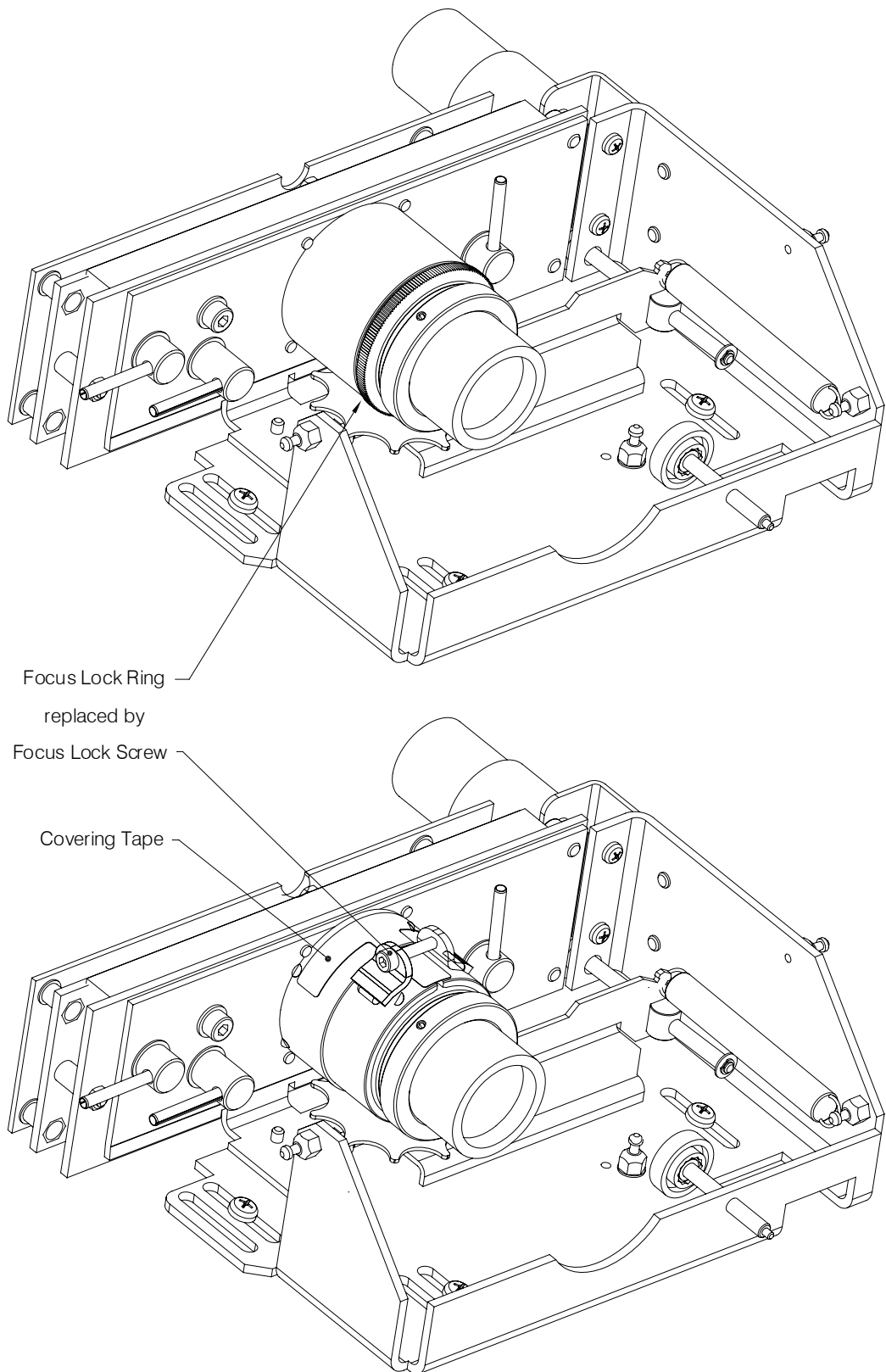

Fig. 4-1 Focus Lock Mechanism

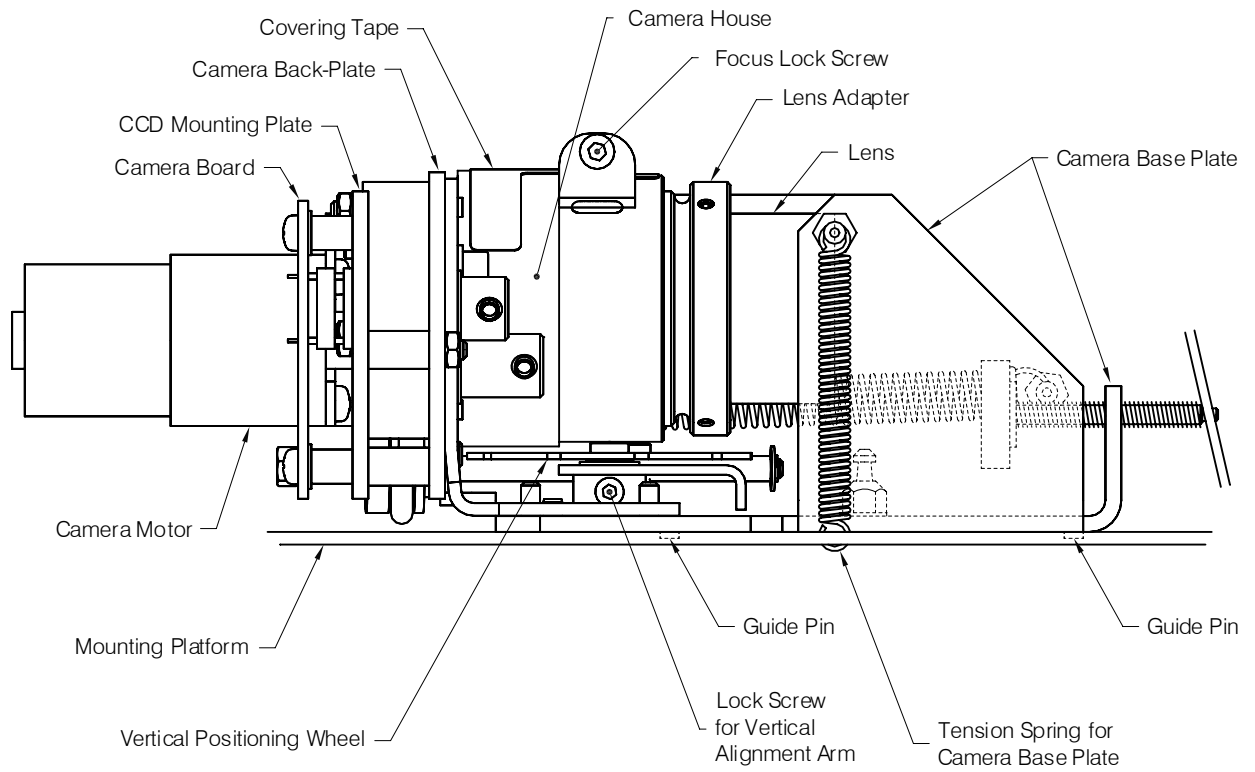

Fig. 4-2 CCD-Camera, Side View

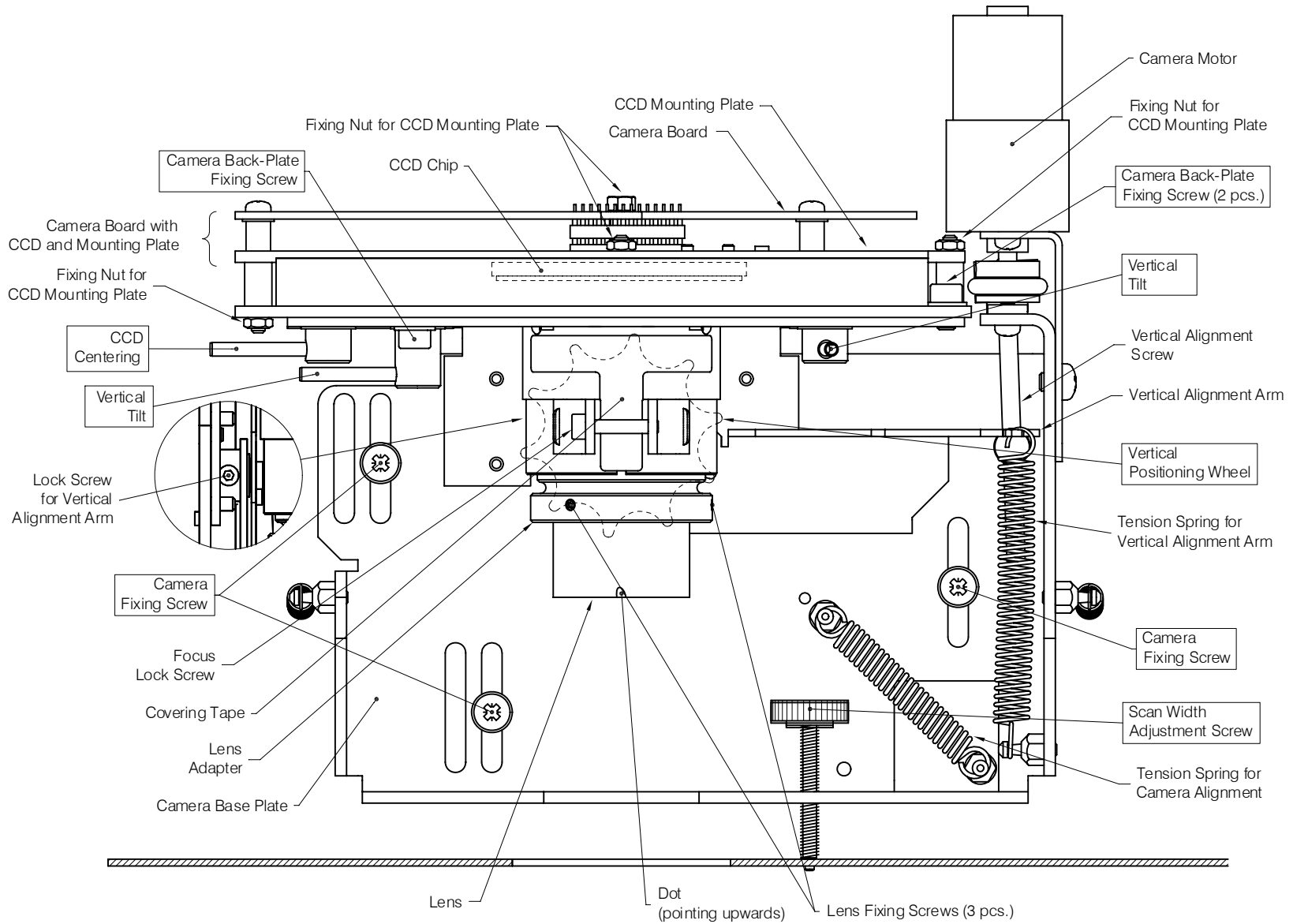

Fig. 4-3 CCD-Camera, Top View

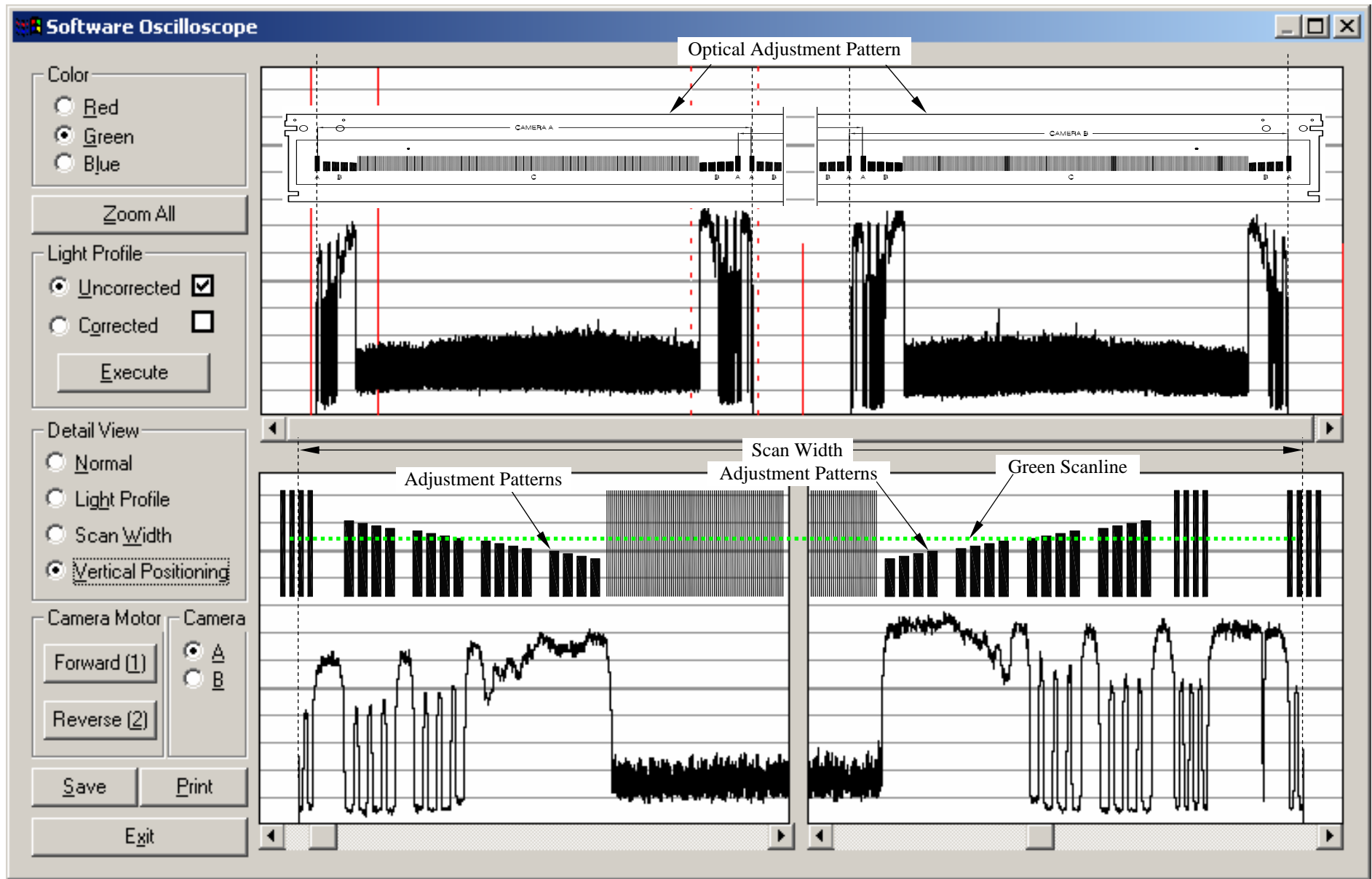

Fig. 4-4 Relations between Optical Adjustment Pattern and Screen Images

4.2 CCD-Camera Check and Adjustment

To get access to the CCD Cameras the Top Cover must be removed.

Equipment needed:

- PC with SCANtest 6 and Scanner Maintenance installed:

COUGAR 25, 36:	USB or SCSI interface
CHAMELEON 25, 36, PREMIER 36:	USB interface
CHROMA Tx 40, CRYSTAL Tx 40:	IEEE 1394 or SCSI interface
MAGNUM XL 54:	IEEE 1394 or SCSI interface
COUGAR Tx 36, CHAMELEON Tx 36:	IEEE 1394 or SCSI interface
PREMIER Tx 36:	IEEE 1394 or SCSI interface

- Optical Adjustment Pattern:

COUGAR 25, CHAMELEON 25:	6779D105
COUGAR 36, CHAMELEON 36, CHAMELEON PREMIER 36:	6779D107
CHROMA Tx 40, CRYSTAL Tx 40:	6779D102
MAGNUM XL 54:	6779D130
COUGAR Tx 36, CHAMELEON Tx 36 PREMIER Tx 36:	6779D127

- Focus Pattern:

COUGAR 25, CHAMELEON 25:	6779D215
COUGAR 36, CHAMELEON 36, CHAMELEON PREMIER 36, CHROMA Tx 40, CRYSTAL Tx 40 COUGAR Tx 36, CHAMELEON Tx 36 PREMIER Tx 36:	6779D216
MAGNUM XL 54:	6779D228

CCD-Camera and adjustment tools are shown in:

- Fig. 4-44 CCD-Camera Overview (Adjustments), page 121
- Fig. 4-45 Optical Adjustment Pattern, 25", page 122
- Fig. 4-46 Optical Adjustment Pattern, 2 Cam., 36", page 123
- Fig. 4-47 Optical Adjustment Pattern, 2 Cam., 40", page 124
- Fig. 4-48 Optical Adjustment Pattern, 3 Cam., 40", page 125
- Fig. 4-49 Optical Adjustment Pattern, 4 Cam., 54", page 126

- Fig. 4-50 Focus Pattern, 25", page 127
 Fig. 4-51 Focus Pattern, 40", page 128
 Fig. 4-52 Focus Pattern, 54", page 129

In the description of the adjustment procedures, references are made to sub-patterns A, B, and C of the Optical Adjustment Pattern. These sub-patterns are shown in Fig. 4-45, page 122.

4.2.1 Check of Light Profiles

Images of the Light Profiles are shown in:

- Fig. 4-5 COUGAR 25, CHAMELEON 25, Light Profiles Uncorrected , page 89
 Fig. 4-6 COUGAR 25, CHAMELEON 25, Light Profiles Corrected , page 89
 Fig. 4-7 COUGAR 36, CHAMELEON 36, PREMIER 36, Light Profiles Uncorrected, page 90
 Fig. 4-8 COUGAR 36, CHAMELEON 36, PREMIER 36, Light Profiles Corrected, page 90
 Fig. 4-9 CHROMA Tx 40, CRYSTAL Tx 40, Light Profiles Uncorrected, page 91
 Fig. 4-10 CHROMA Tx 40, CRYSTAL Tx 40, Light Profiles Corrected, page 91
 Fig. 4-11 MAGNUM XL 54, Light Profiles Uncorrected, page on page 92
 Fig. 4-12 MAGNUM XL 54, Light Profiles Corrected, page 92
 Fig. 4-13 COUGAR Tx 36, CHAMELEON Tx 36, PREMIER Tx 36, Light Profiles Uncorrected, page 93
 Fig. 4-14 COUGAR Tx 36, CHAMELEON Tx 36, PREMIER Tx 36, Light Profiles Corrected, page 93

Procedure for check of Light Profiles

Place the Original Guide Plate in the scan-area.

Start	SCANtest 6
Select	Test 9
Select	Uncorrected or Corrected Light Profile
Press	Execute
Select	Green (Default for Uncorrected)
Select	Detail View: Light Profile
Select	Camera

Compare the image of the Software Oscilloscope with the relevant sample image listed above.

If the signal levels of the uncorrected Light Profiles differ much from the sample images, the scanner might need to be calibrated by Scanner Maintenance.

4.2.2 Hints

The Detail View “Light Profile” of the Software Oscilloscope shows the images of the Stitching Wire and may be useful when investigating Stitching problems.

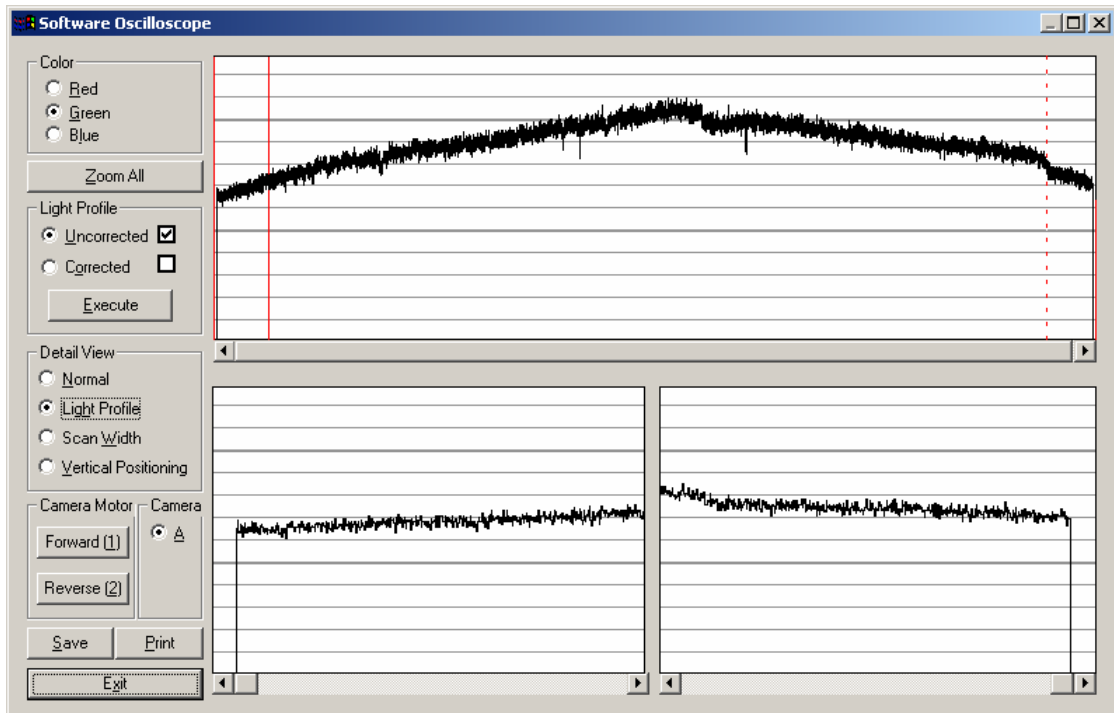

Fig. 4-5 COUGAR 25, CHAMELEON 25, Light Profiles Uncorrected

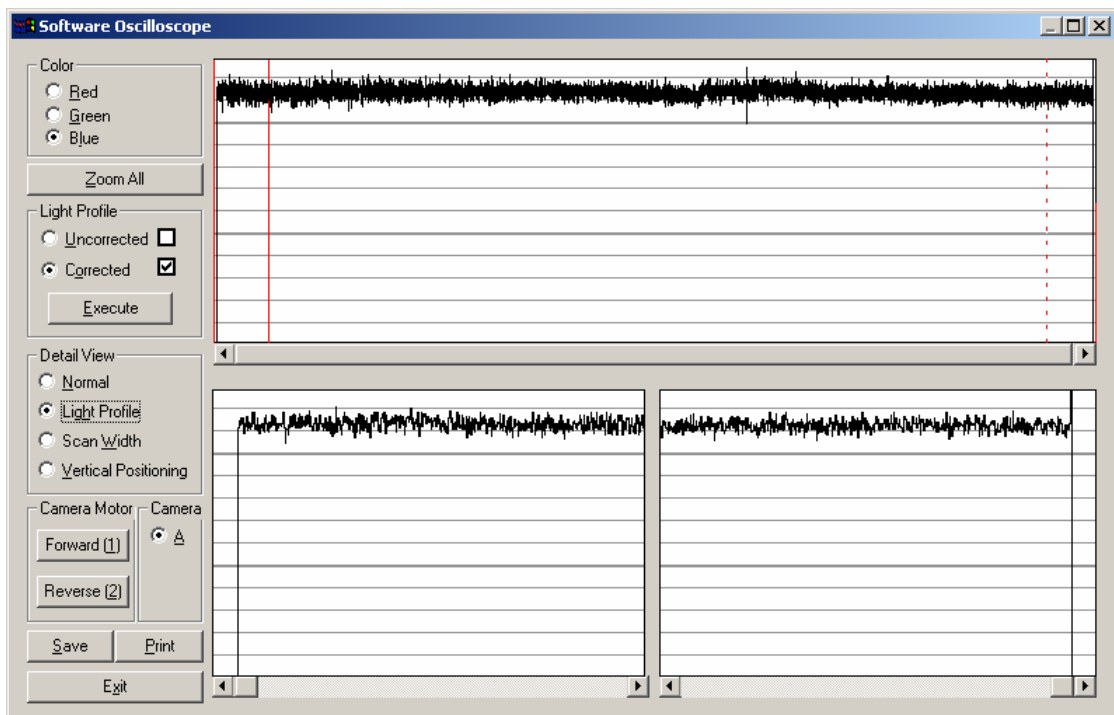

Fig. 4-6 COUGAR 25, CHAMELEON 25, Light Profiles Corrected

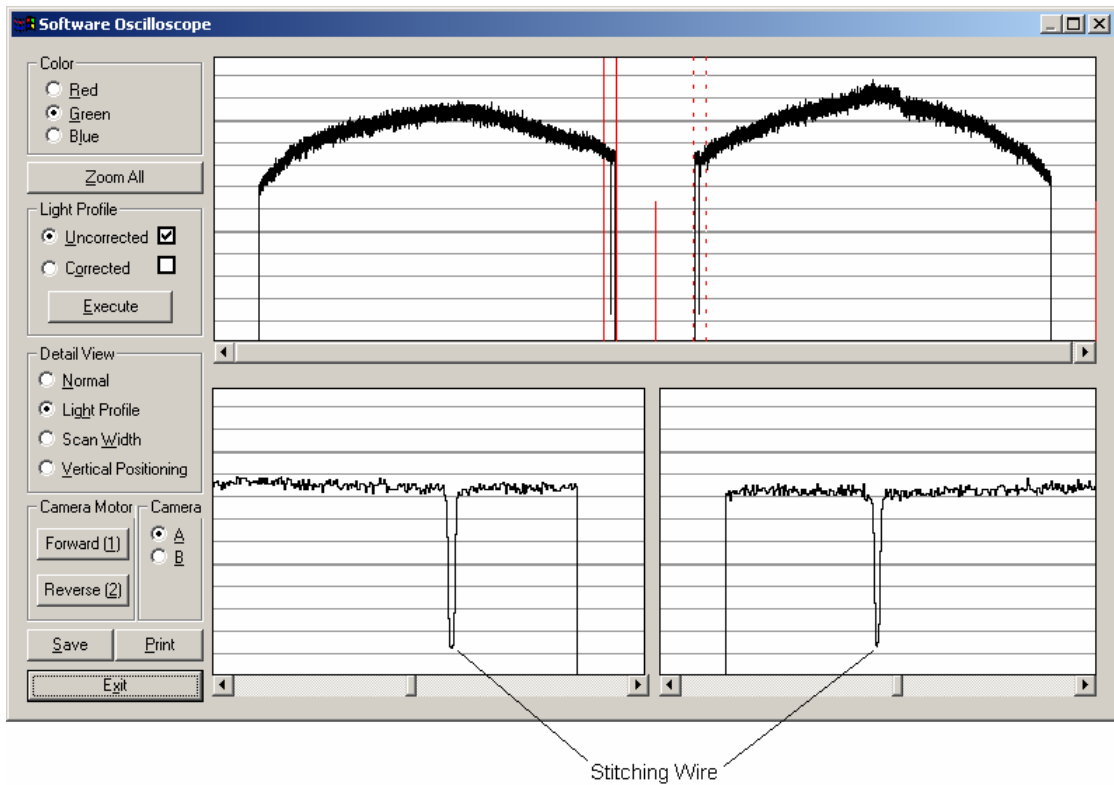

Fig. 4-7 COUGAR 36, CHAMELEON 36, PREMIER 36, Light Profiles Uncorrected

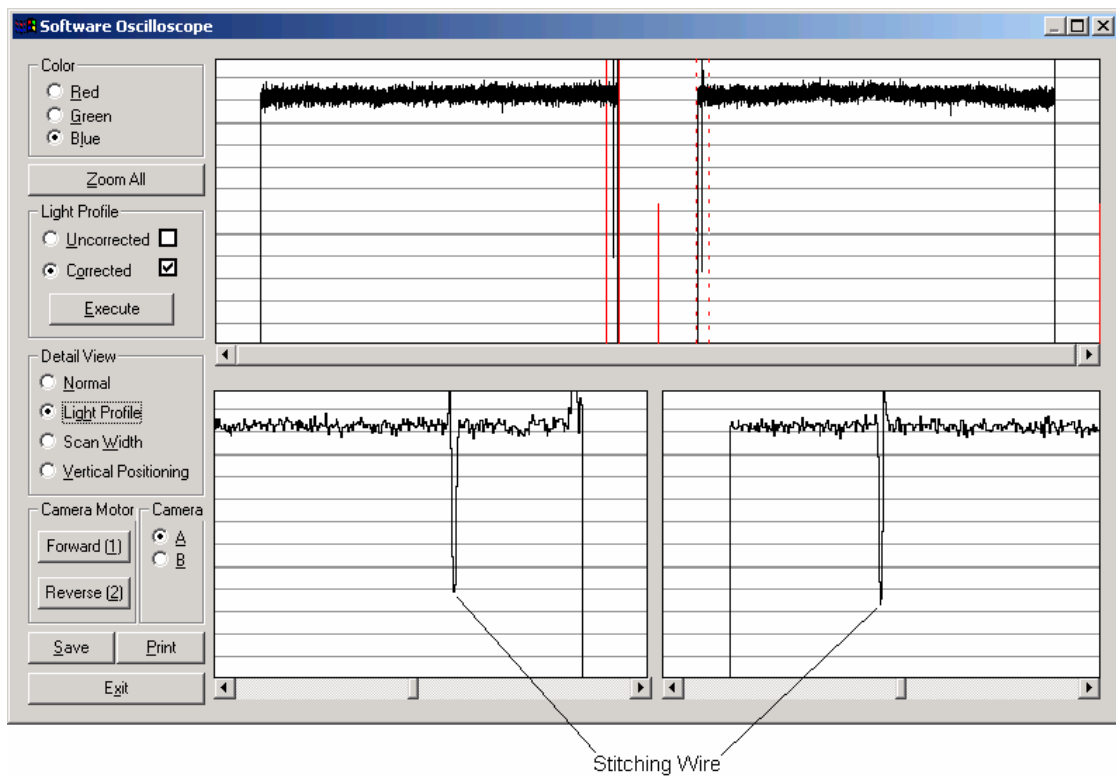

Fig. 4-8 COUGAR 36, CHAMELEON 36, PREMIER 36, Light Profiles Corrected

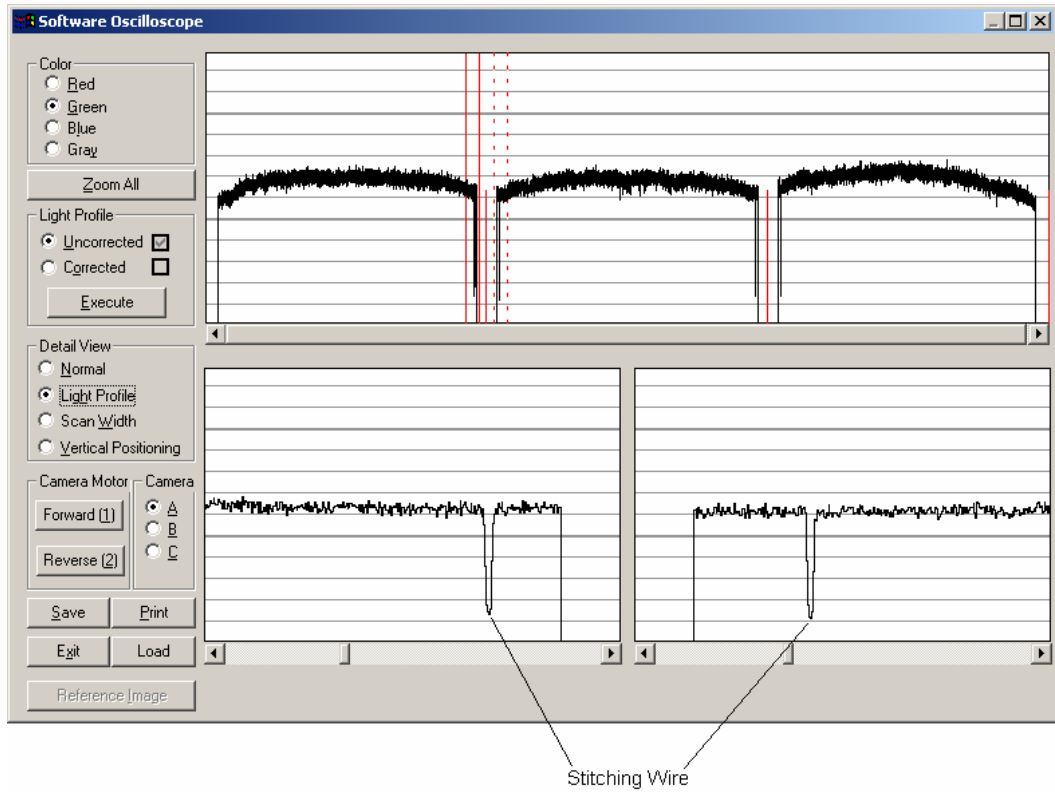

Fig. 4-9 CHROMA Tx 40, CRYSTAL Tx 40, Light Profiles Uncorrected

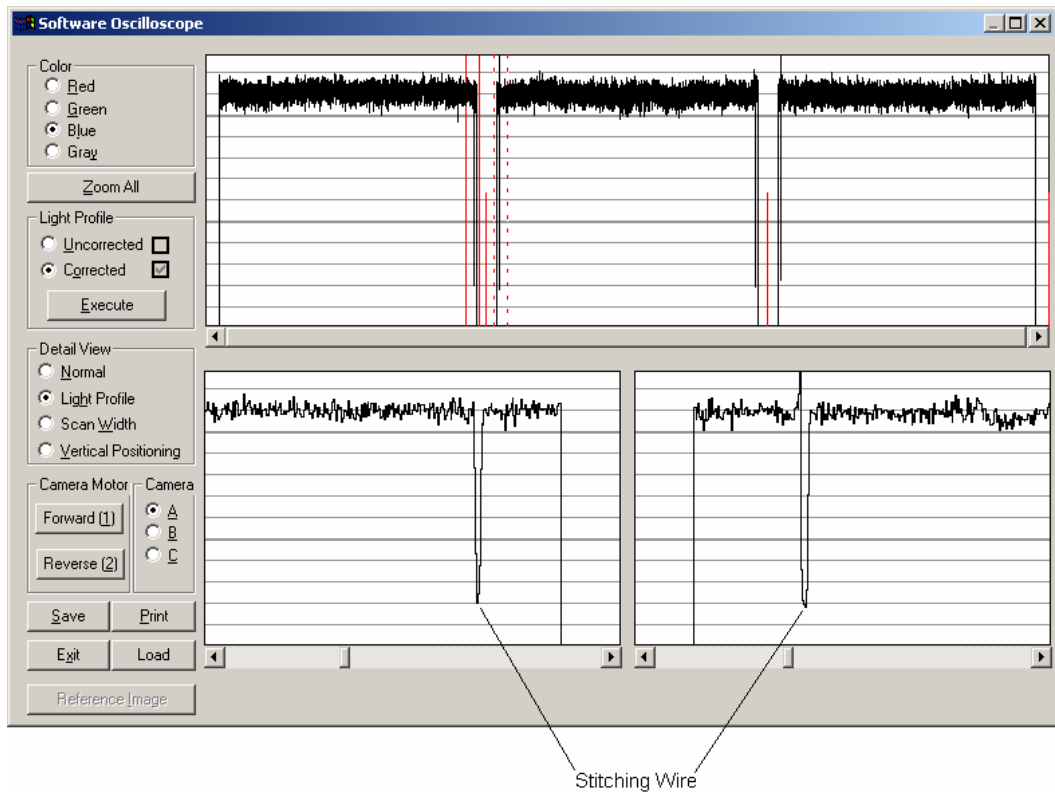

Fig. 4-10 CHROMA Tx 40, CRYSTAL Tx 40, Light Profiles Corrected

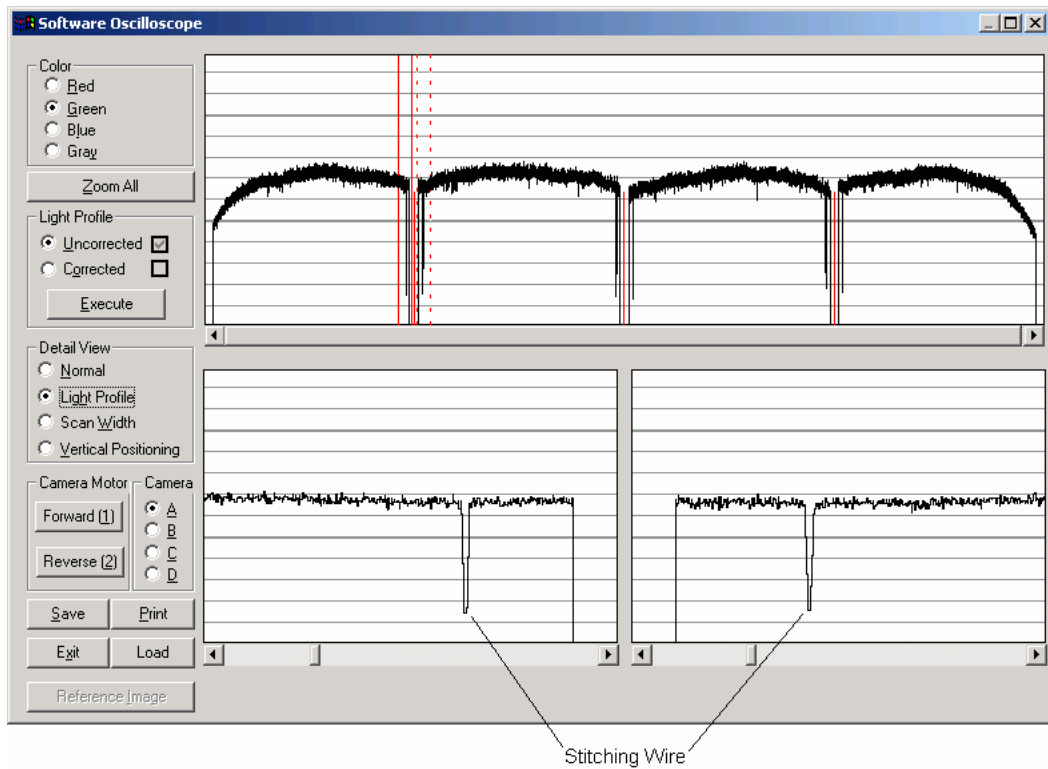

Fig. 4-11 MAGNUM XL 54, Light Profiles Uncorrected

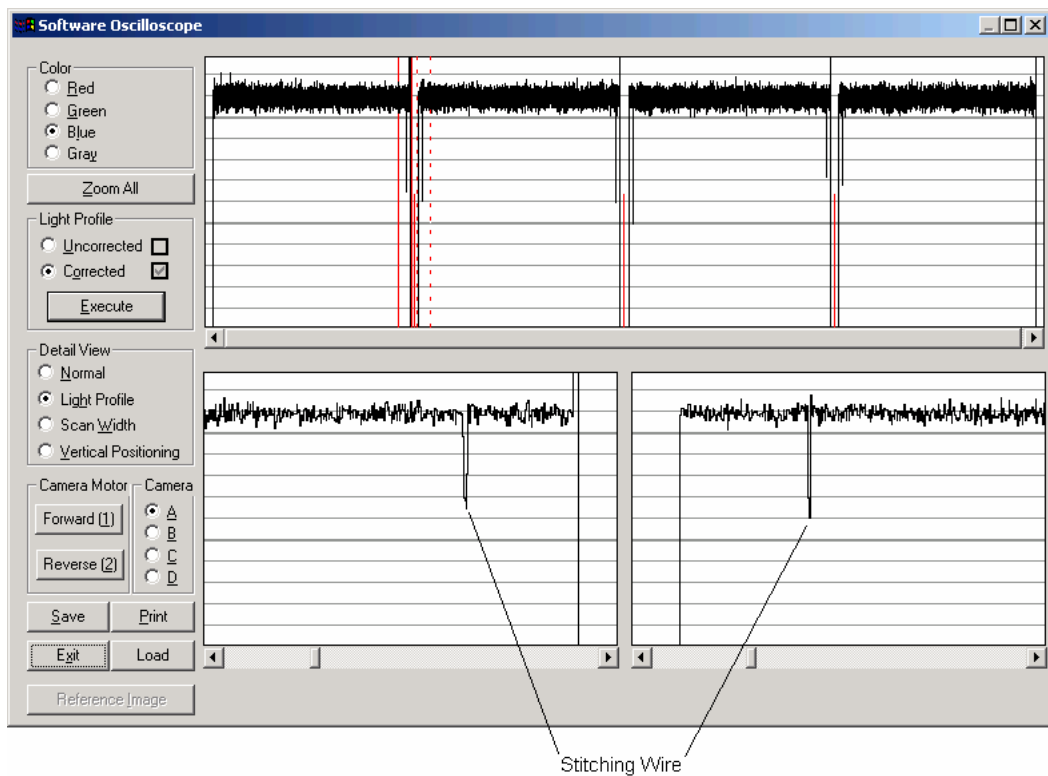

Fig. 4-12 MAGNUM XL 54, Light Profiles Corrected

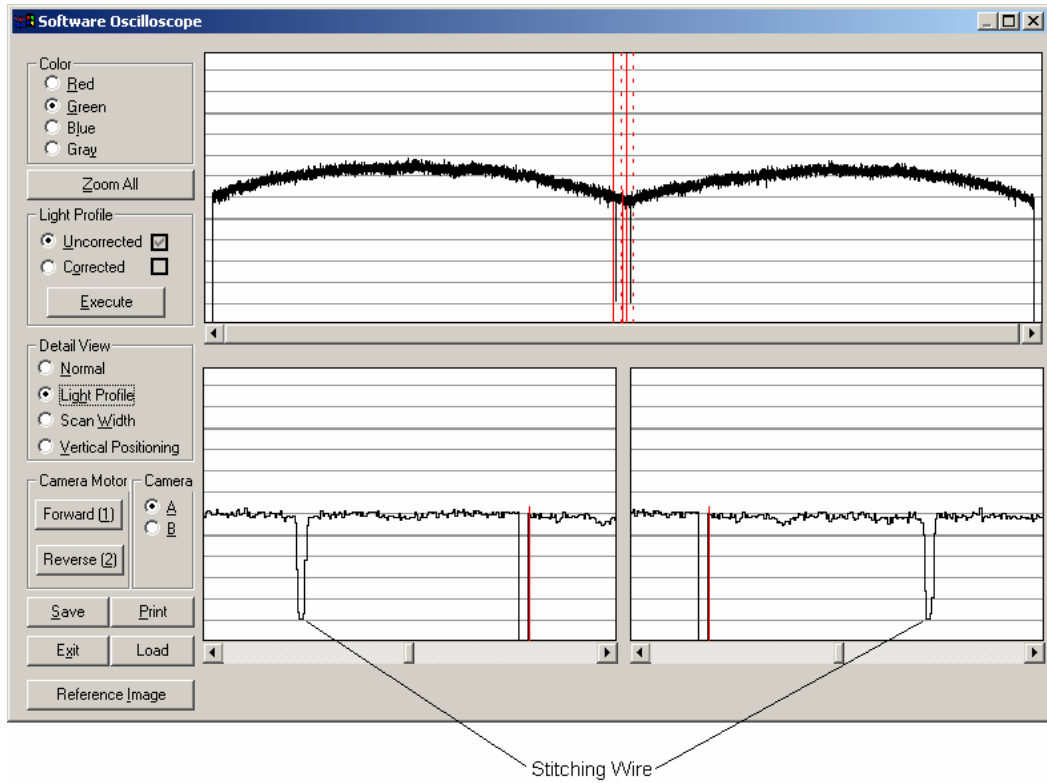

Fig. 4-13 COUGAR Tx 36, CHAMELEON Tx 36, PREMIER Tx 36, Light Profiles

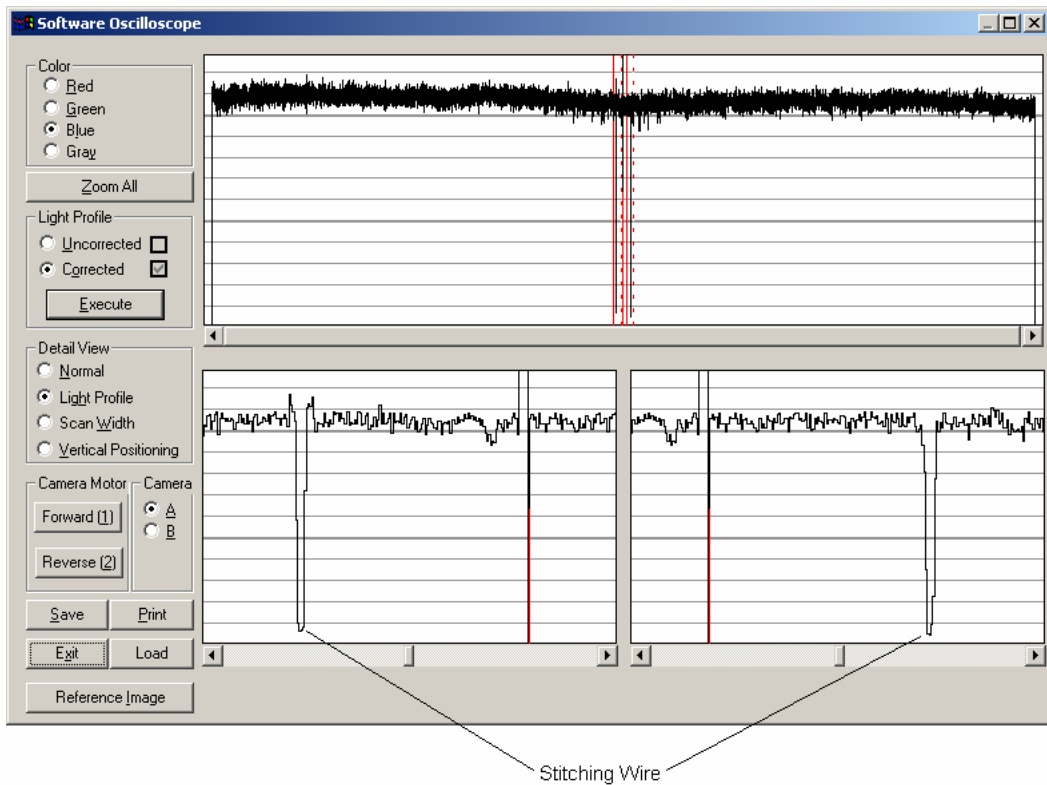

Fig. 4-14 COUGAR Tx 36, CHAMELEON Tx 36, PREMIER Tx 36, Light Profiles

4.2.3 Camera Adjustment Wizard

The Camera Wizard provides a guide for a complete adjustment of all cameras of the actual scanner, that is, the adjustments described in the following sections 4.2.5 through 4.2.7.

Just start SCANtest 6, Test 27 and follow the instructions given by the Wizard.

4.2.4 Check and Adjustment of Focus

Images of the Focus adjustments are shown in:

Fig. 4-15 COUGAR 25, CHAMELEON 25, Focus Signals, page 96

Fig. 4-16 COUGAR 36, CHAMELEON 36, PREMIER 36, Focus Signals, page 96

Fig. 4-17 CHROMA Tx 40, CRYSTAL Tx 40, Focus Signals, page 97

Fig. 4-18 MAGNUM XL 54, Focus Signals, page 97

Fig. 4-19 COUGAR Tx 36, CHAMELEON Tx 36, PREMIER Tx 36, Focus Signals, page 98

Adjustment Procedure

Do not loosen the camera. The construction of the camera ensures that the optical axis of the lens is perpendicular to the scanning area and hence no alignment of the camera housing is necessary.

Always perform the Focus adjustment before adjusting the Scan-Width, see “Interaction” below.

Start	SCANtest 6
Select	Test 9
Select	Corrected Light Profile*)
Press	Execute

*) *Note:* If the camera is completely out of adjustment it may not be possible to run Test 9 in ‘Corrected’ mode. In that case, select ‘Uncorrected’ and with the Optical Adjustment Pattern placed in the scan-area make a coarse adjustment of Focus and Scan-Width before continuing.

Select	Blue (Default)
Select	Detail View: Light Profile

Insert the Focus Pattern and feed it by using the Forward Key until the image of the pattern with the resolution as shown below is seen on the upper image on the screen:

Model	Focus Pattern	Resolution
COUGAR 25, CHAMELEON 25	6779D215	3.3 lp/mm
COUGAR 36, CHAMELEON 36, CHAMELEON PREMIER 36,	6779D216	3.3 lp/mm

CHROMA Tx 40, CRYSTAL Tx 40		
COUGAR Tx 36, CHAMELEON Tx 36, PREMIER Tx 36		
MAGNUM XL 54	6779D228	3.3/ lp/mm

Loosen the Focus Lock Ring / Lock Screw (see Fig. 4-1) and turn the Lens Adapter to get maximum amplitude of the Focus signal (approximately 5 division peak-to-peak).

The amplitude of the Focus signal (Corrected) should be even within:

Min/Max > 0.7 for each separate camera.

Min/Max > 0.8 at the transition between adjacent cameras (measured at the position of the image of the Stitching Wire, see Detail View on page 96).

If the dot does not point in upwards direction after focusing (indicating the 'best position' of the Lens):

Mark the upward direction on the Lens Adapter

Loosen the Focus Lock Ring / Lock Screw

Turn the Lens Adapter and loosen the Lens Fixing Screws

Rotate the lens to align the dot with the upward mark on the Lens Adapter

Tighten the Lens Fixing Screws (do not over-tighten)

Turn the Lens Adapter to readjust the Focus and tighten the Focus Lock Ring / Lock Screw to secure the Focus setting.

Interaction

The Focus adjustment has a big influence on the Scan-Width adjustment. Therefore the Scan-Width must be checked and readjusted if necessary when the Focus adjustment has been changed. On the other hand, the Focus adjustment is relative tolerant to changes in the Scan-Width adjustment and as a rule of thumb, the Scan-Width adjustment can be changed ± 1 SWU without the need for re-focusing.

When all camera adjustments have been completed, run Scanner Maintenance.

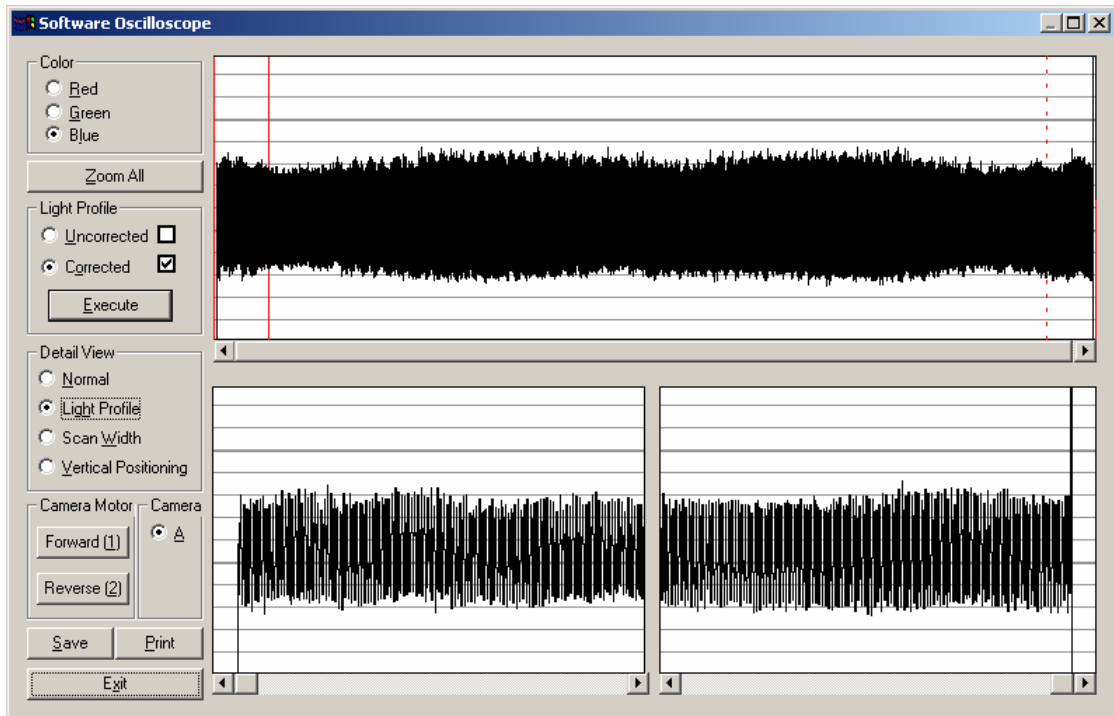

Fig. 4-15 COUGAR 25, CHAMELEON 25, Focus Signals

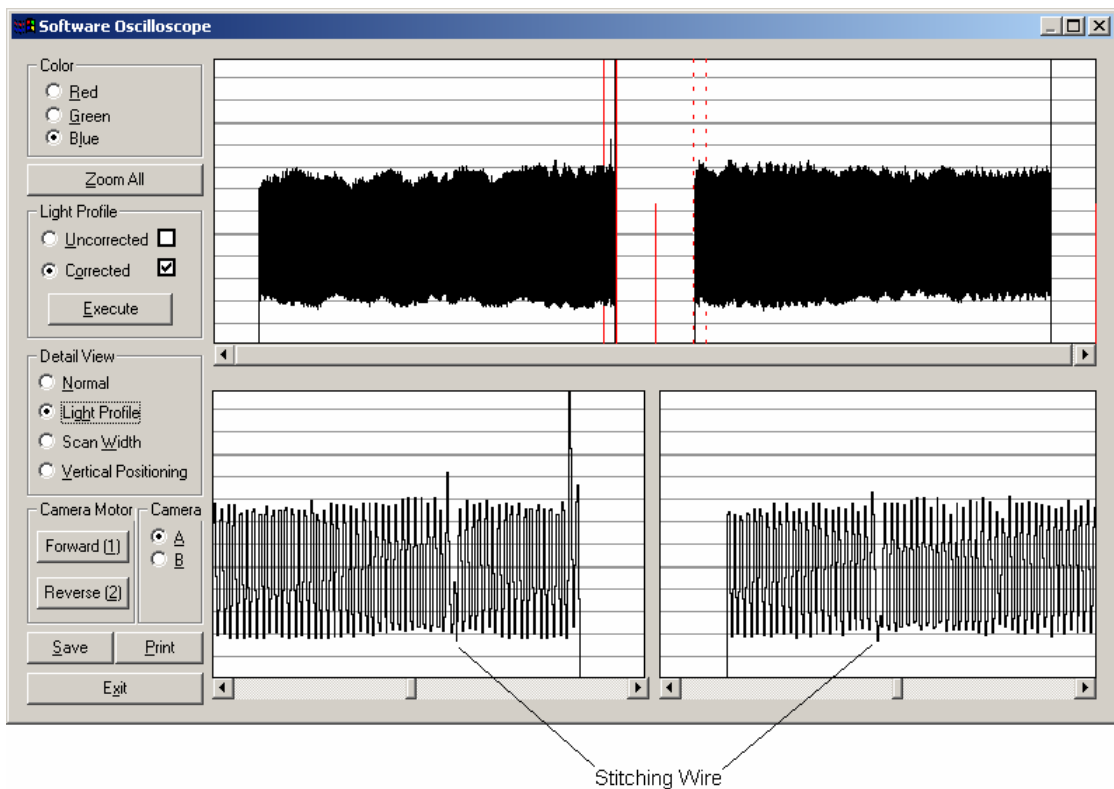

Fig. 4-16 COUGAR 36, CHAMELEON 36, PREMIER 36, Focus Signals

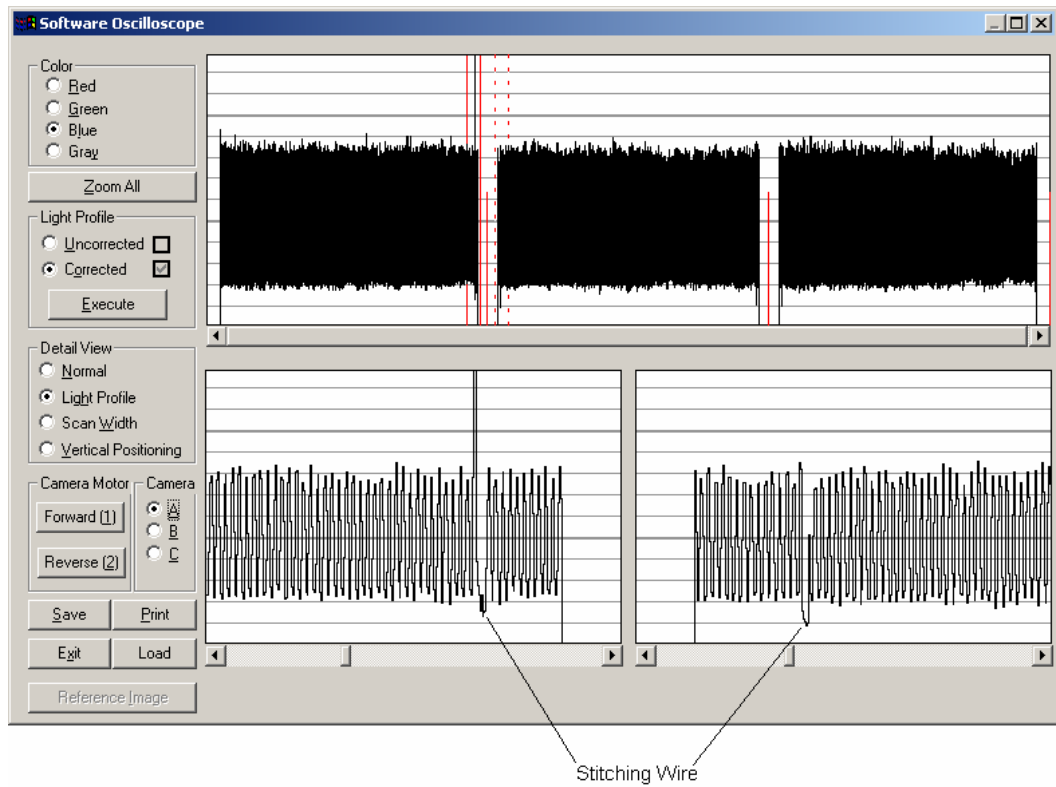

Fig. 4-17 CHROMA Tx 40, CRYSTAL Tx 40, Focus Signals

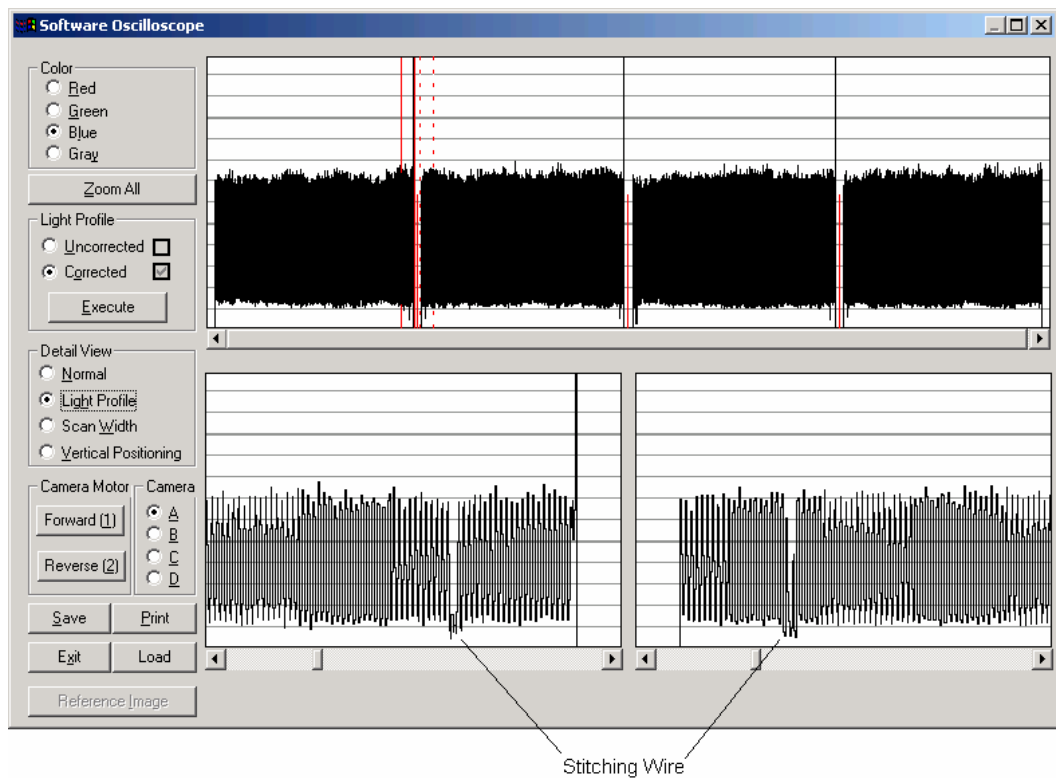

Fig. 4-18 MAGNUM XL 54, Focus Signals

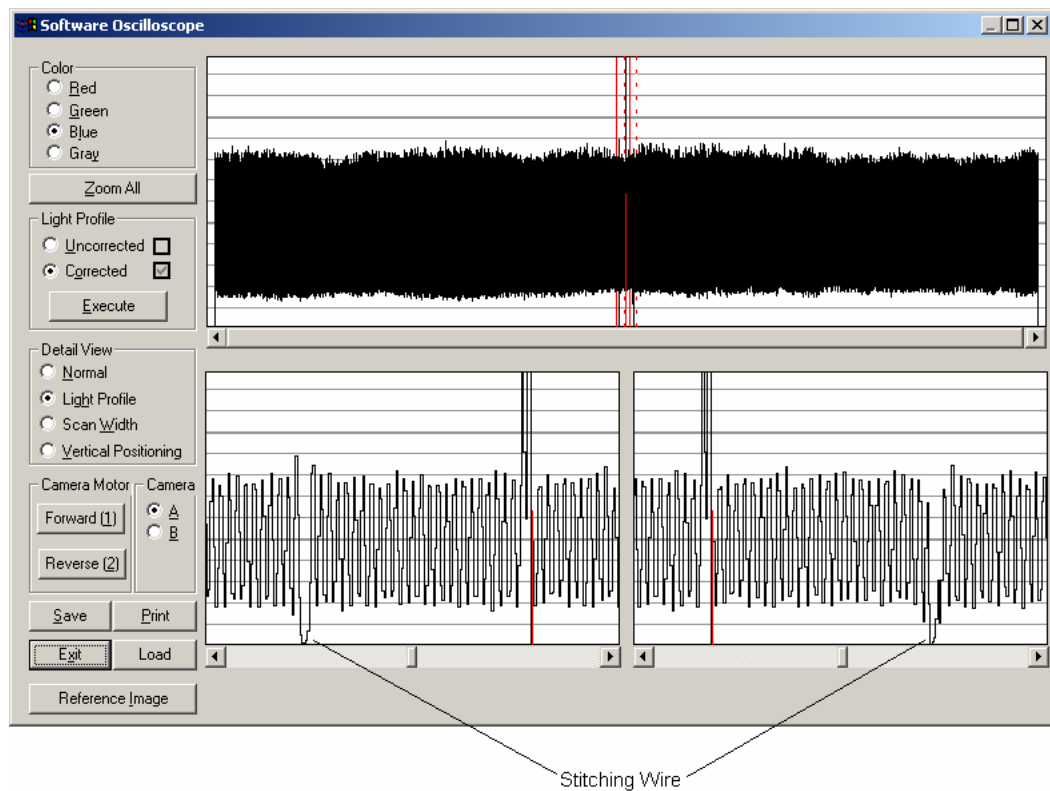

Fig. 4-19 COUGAR Tx 36, CHAMELEON Tx 36, PREMIER Tx 36, Focus Signals

4.2.5 Check and Adjustment of Scan-Width

Images of the Scan-Width adjustments are shown in:

- Fig. 4-20 COUGAR 25, CHAMELEON 25, Scan-Width, page 102
- Fig. 4-21 COUGAR 36, CHAMELEON 36, PREMIER 36, Scan-Width (A), page 103
- Fig. 4-22 COUGAR 36, CHAMELEON 36, PREMIER 36, Scan-Width (B), page 103
- Fig. 4-23 CHROMA Tx 40, CRYSTAL Tx 40, Scan-Width (A), page 104
- Fig. 4-24 CHROMA Tx 40, CRYSTAL Tx 40, Scan-Width (B), page 104
- Fig. 4-25 CHROMA Tx 40, CRYSTAL Tx 40, Scan-Width (C), page 105
- Fig. 4-26 MAGNUM XL 54, Scan-Width (A), page 106
- Fig. 4-27 MAGNUM XL 54, Scan-Width (B), page 106
- Fig. 4-28 MAGNUM XL 54, Scan-Width (C), page 107
- Fig. 4-29 MAGNUM XL 54, Scan-Width (D), page 107
- Fig. 4-30 COUGAR Tx 36, CHAMELEON Tx 36, PREMIER Tx 36, Scan-Width (A), page 108
- Fig. 4-31 COUGAR Tx 36, CHAMELEON Tx 36, PREMIER Tx 36, Scan-Width (B), page 108

The aim of this adjustment is to obtain a camera Scan-Width of:

COUGAR 25, CHAMELEON 25:	635 mm
COUGAR 36, CHAMELEON 36, PREMIER 36:	516 mm
CHROMA Tx 40, CRYSTAL Tx 40:	344.4/350.2/344.4 mm
MAGNUM XL 54:	350.9/358.9/358.9/350.9 mm
COUGAR Tx 36, CHAMELEON Tx 36, PREMIER Tx 36:	466.7 mm

The Scan-Width is correct if the total sum of Scan-Width Units (SWU) at the start and at the end of the scanline is as shown in the table below (*1 SWU is either 1 Black Line or 1 White Space of the Scan-Width Pattern (A)*).

Model	Optical Adjustment Pattern	Total sum of Scan-Width Units	Tolerance
COUGAR 25, CHAMELEON 25	6779D105, sub-pattern A	6	±0.5 SWU
COUGAR 36, CHAMELEON 36, PREMIER 36	6779D107, sub-pattern A	6	±0.5 SWU
CHROMA Tx 40, CRYSTAL Tx 40	6779D102, sub-pattern A	6	±0.5 SWU
MAGNUM XL 54	6779D130, , sub-pattern A	6	±0.5 SWU
COUGAR Tx 36, CHAMELEON Tx 36, PREMIER Tx 36	6779D127, sub-pattern A	6	±0.5 SWU

The tolerance corresponds to approximately 0.10% on the Scan-Width (scaling error).

Adjustment Procedure

Always do the Focus adjustment before adjusting the Scan-Width, see “Interaction” below.

Place the Optical Adjustment Pattern (see table above) in the scan-area.

Align the Adjustment Pattern by pushing it sideways towards the Operator Panel and towards the rear of the scanner.

Start	SCANtest 6
Select	Test 9
Select	Uncorrected Light Profile
Press	Execute
Select	Green (Default)
Select	Detail View: Scan Width
Select	Camera

Loosen the three Camera fixing screws and the three Camera Back-Plate fixing screws, see Fig. 4-44, page 121. The screws should be loosened just enough to allow the Camera and the Camera Back-Plate to be moved.

Adjust the Scan-Width by turning the Scan-Width Adjustment Screw (which moves the Camera back and forth) to get the correct total sum of Scan-Width Units, see the table above (at least 1 black line must be clearly visible at the start as well as at the end of the scanline). One full turn of the Scan-Width Adjustment Screw changes the Scan-Width approximately 0.6 SWU.

Tighten the Camera fixing screws. Make sure that the Camera is kept aligned by pushing it forward and to the left before tightening the screws.

Interaction

Check Focus and readjust if necessary.

The Focus adjustment has a big influence on the Scan-Width adjustment. Therefore the Scan-Width must be checked and, if necessary, readjusted when the Focus adjustment has been changed. On the other hand, the Focus adjustment is relative tolerant to changes in the Scan-Width adjustment and as a rule of thumb, the Scan-Width adjustment can be changed ± 1 SWU without the need for re-focusing.

When all camera adjustments have been completed, run Scanner Maintenance.

Note

The horizontal (X-axis) accuracy of the scanner depends on the distance between camera and scan-area.

Scaling errors may be corrected as follows:

If the scanned image is too big:

Turn the Scan-Width Adjustment Screw CW (increase the Scan-Width).

If the scanned image is too small:

Turn the Scan-Width Adjustment Screw CCW (decrease the Scan-Width).

The Scan-Width Adjustment Screw should be turned approx. 1 turn per 0.1% error.

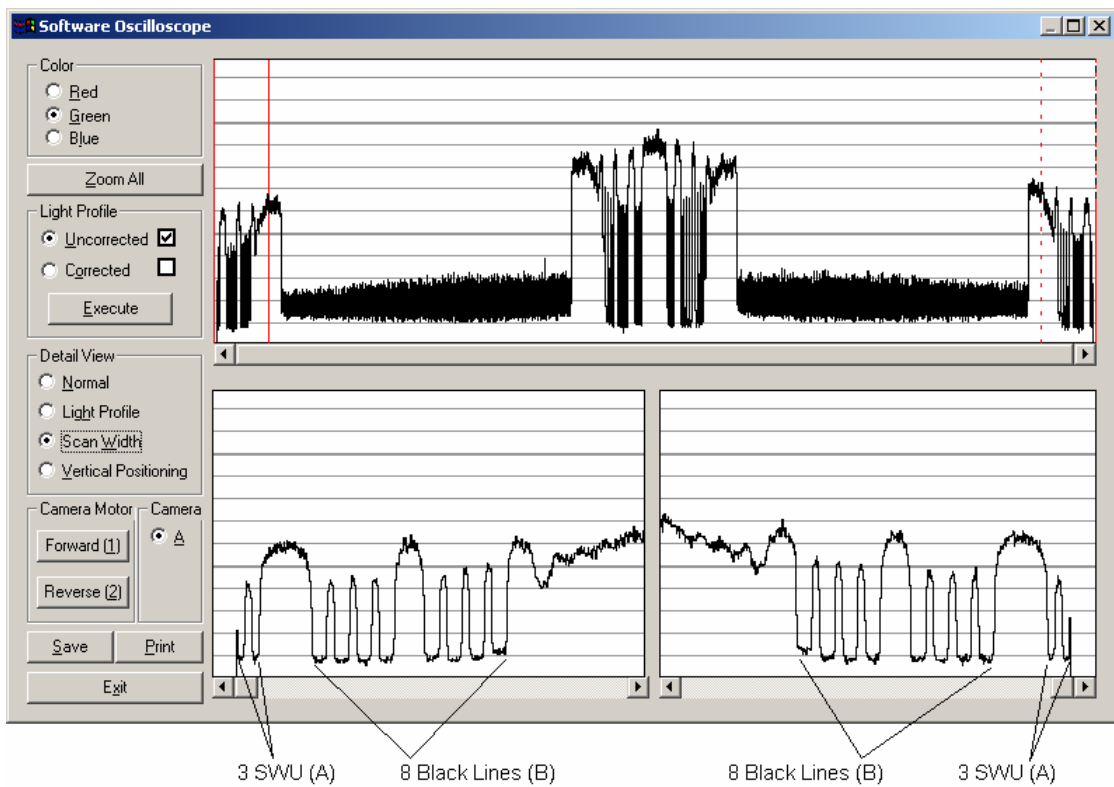

Fig. 4-20 COUGAR 25, CHAMELEON 25, Scan-Width

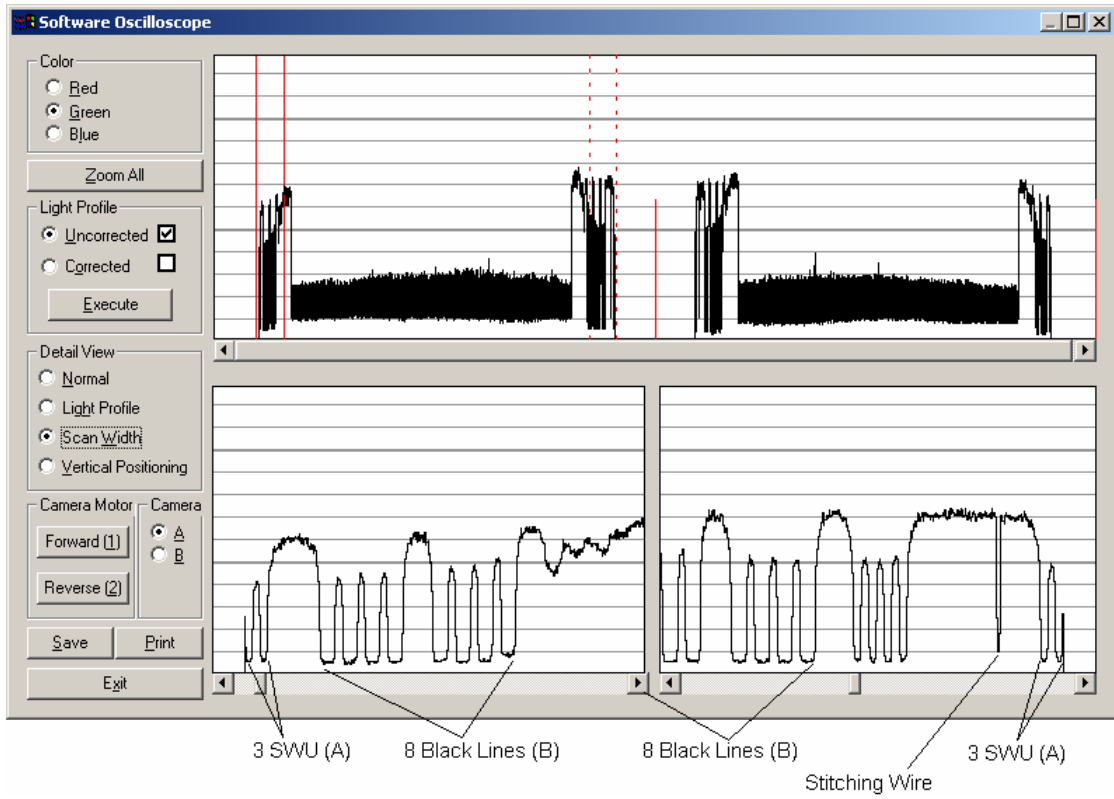

Fig. 4-21 COUGAR 36, CHAMELEON 36, PREMIER 36, Scan-Width, Camera A

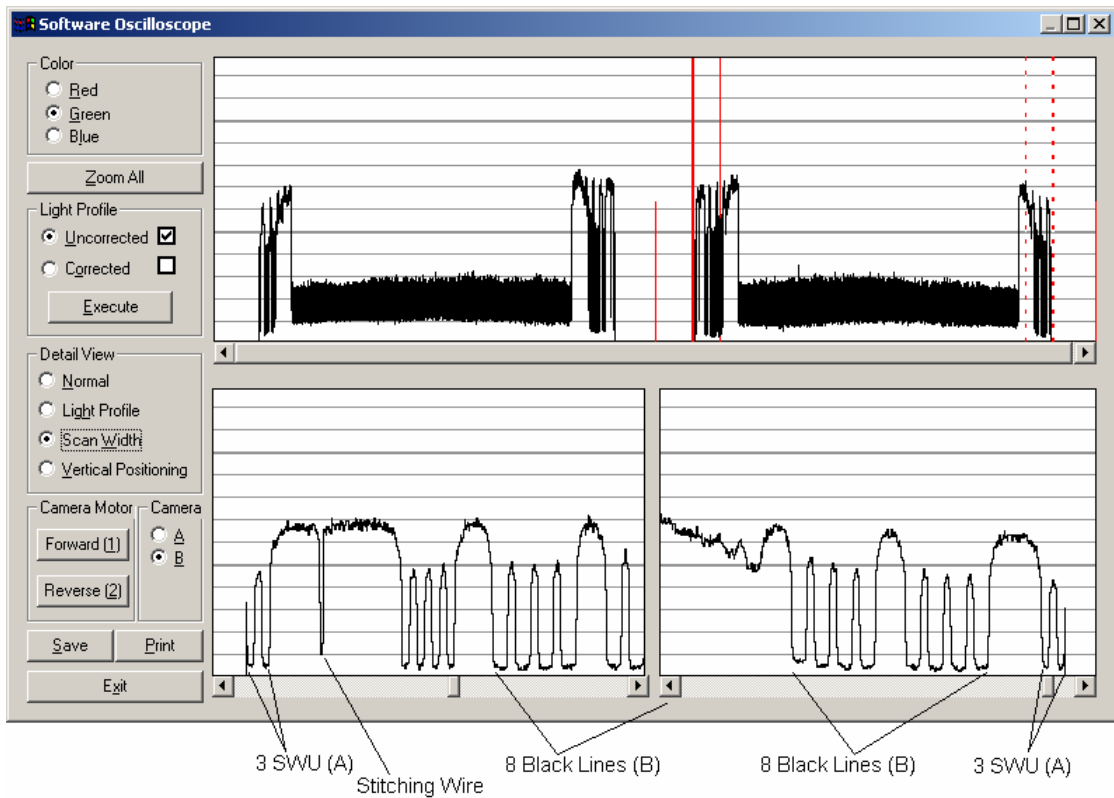

Fig. 4-22 COUGAR 36, CHAMELEON 36, PREMIER 36, Scan-Width, Camera B

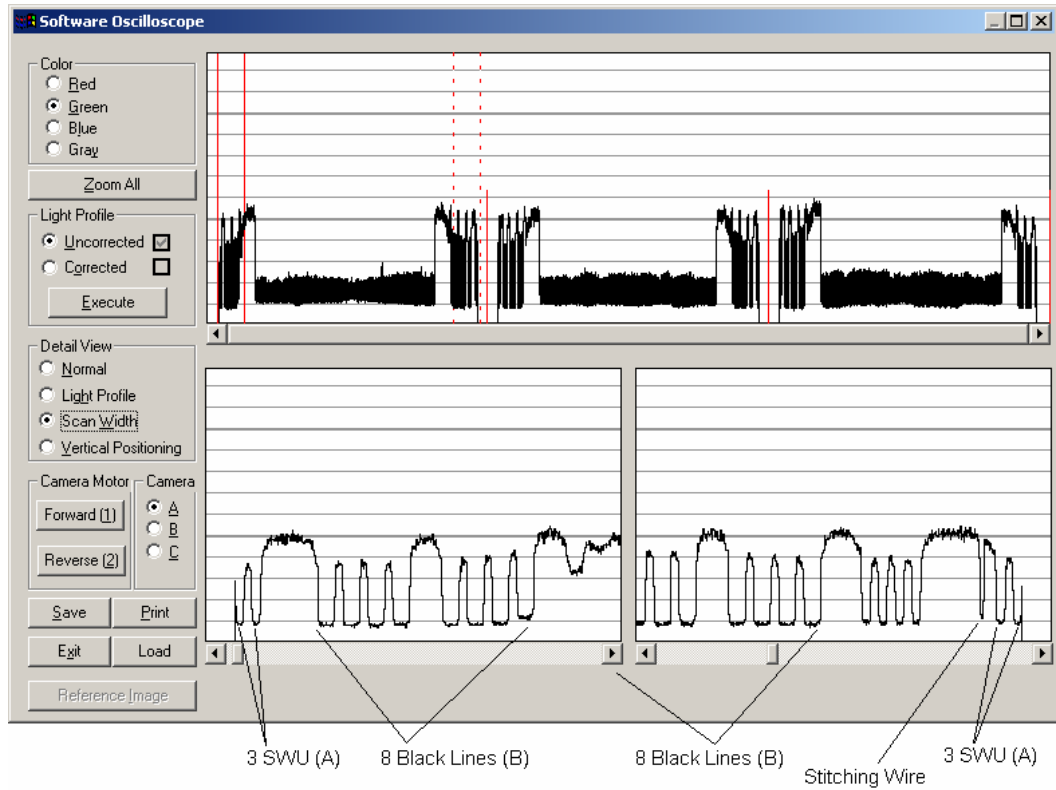

Fig. 4-23 CHROMA Tx 40, CRYSTAL Tx 40, Scan-Width, Camera A

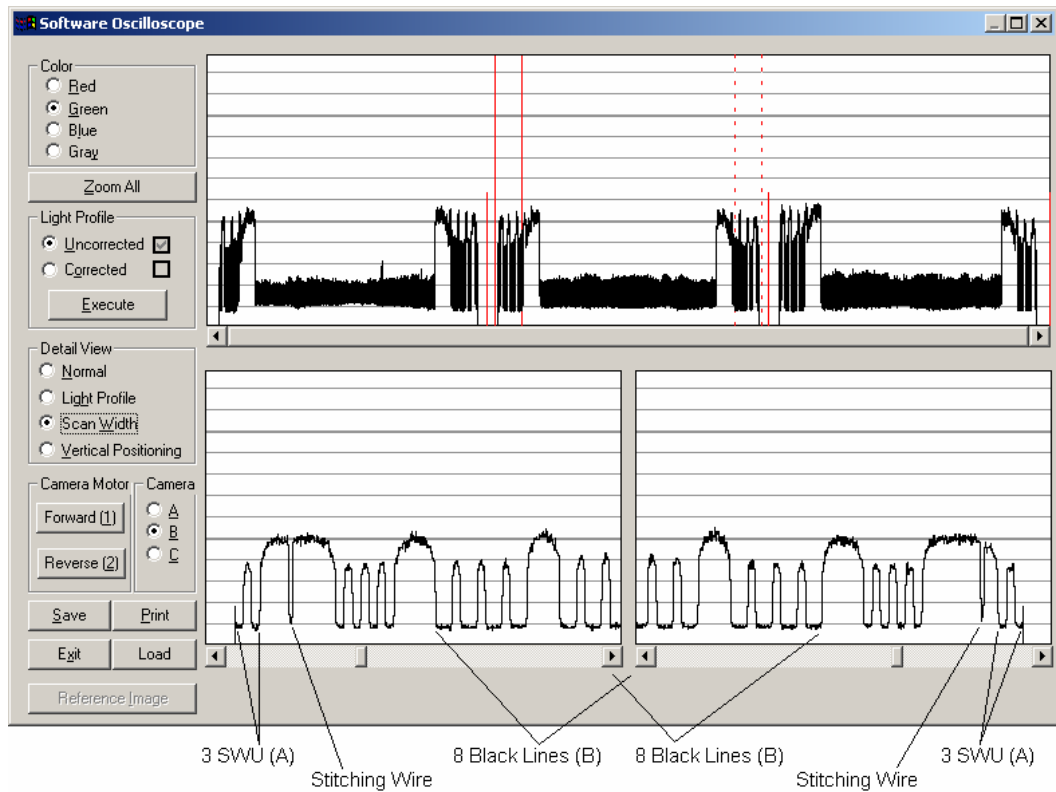

Fig. 4-24 CHROMA Tx 40, CRYSTAL Tx 40, Scan-Width, Camera B

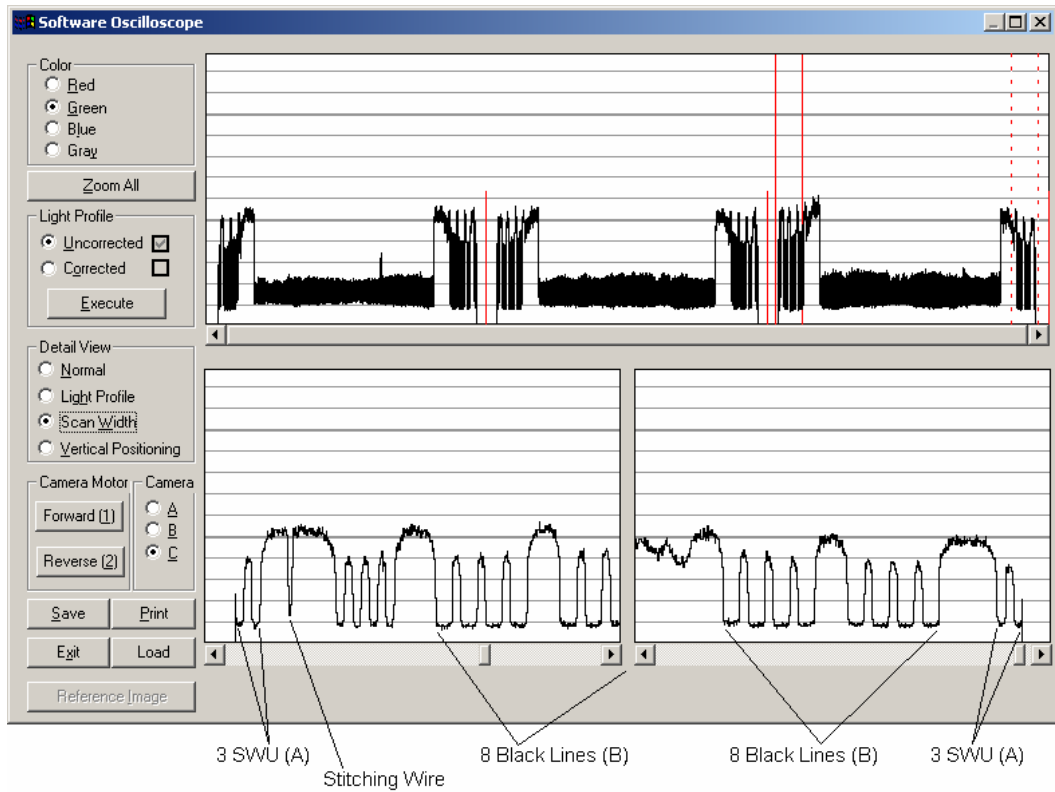

Fig. 4-25 CHROMA Tx 40, CRYSTAL Tx 40, Scan-Width, Camera C

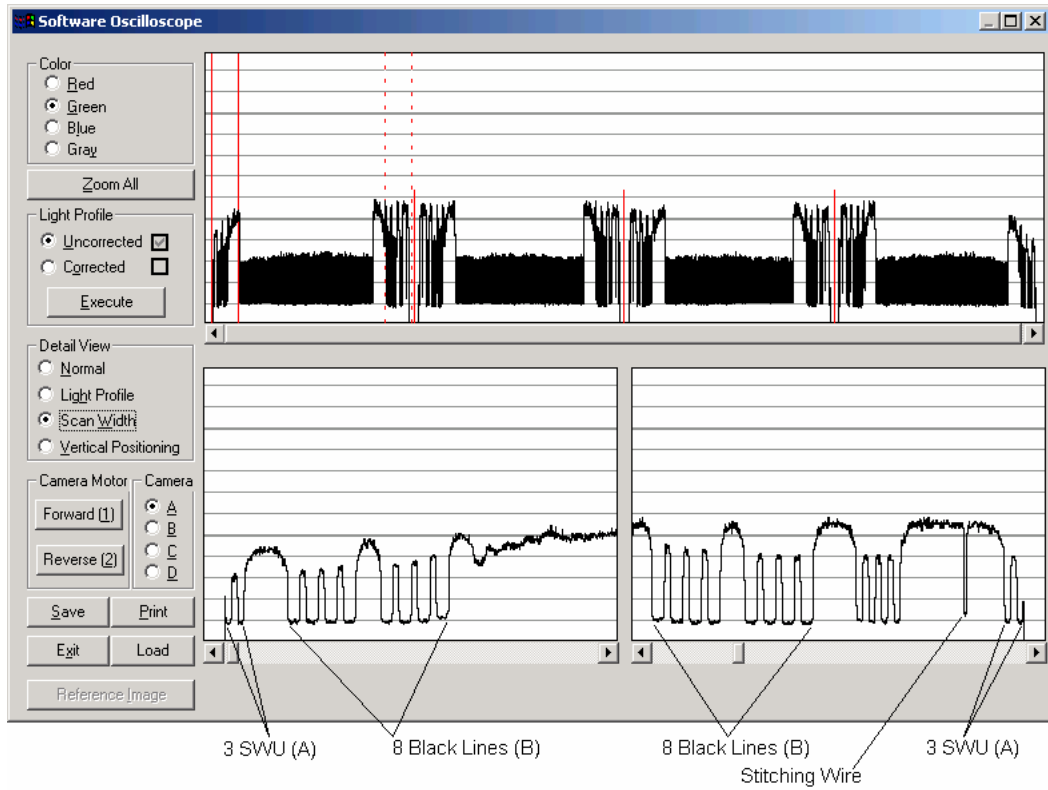

Fig. 4-26 MAGNUM XL 54, Scan-Width, Camera A

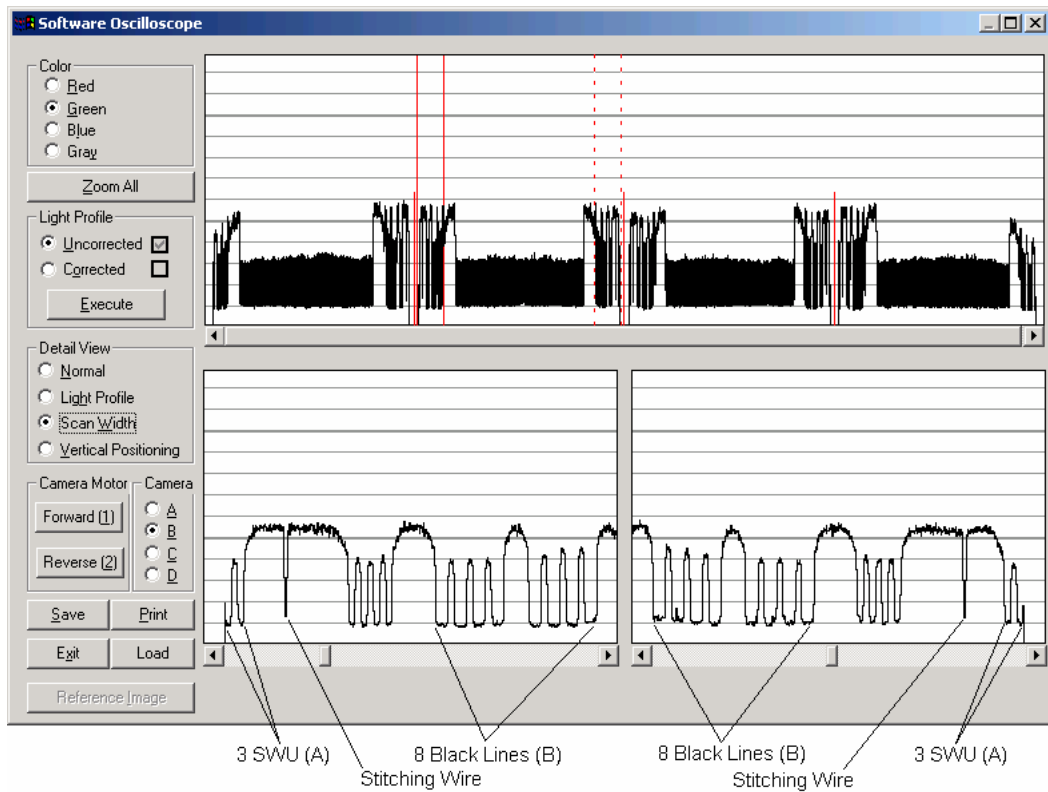

Fig. 4-27 MAGNUM XL 54, Scan-Width, Camera B

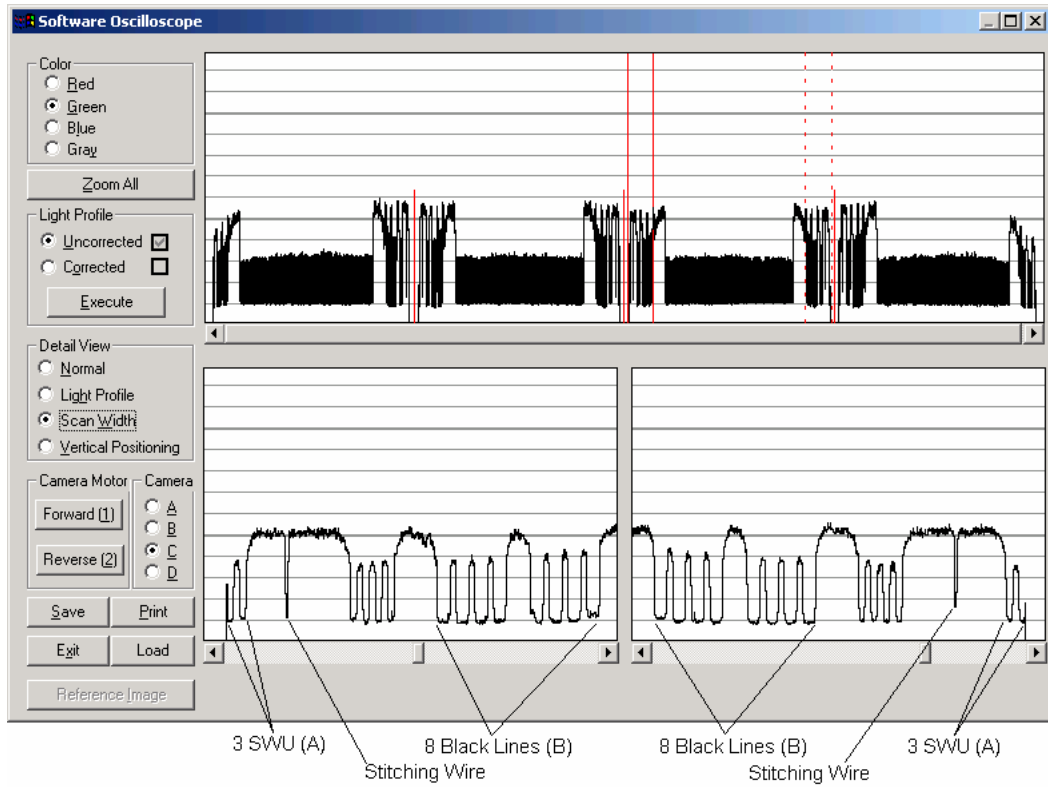

Fig. 4-28 MAGNUM XL 54, Scan-Width, Camera C

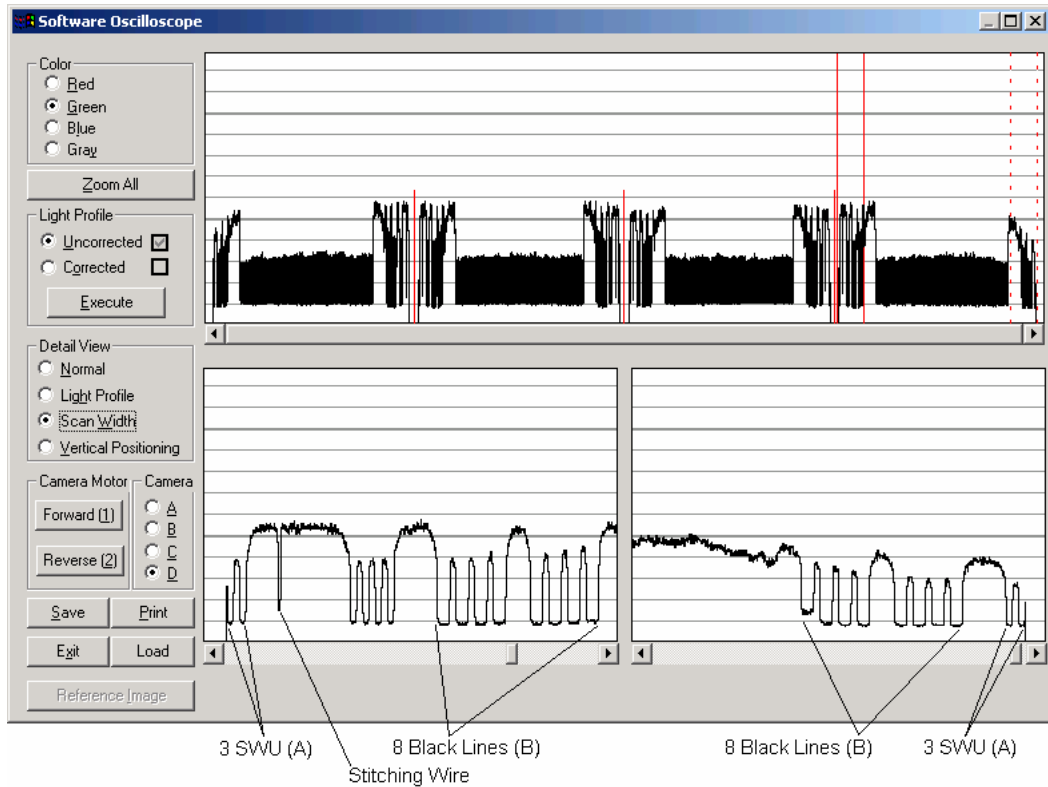

Fig. 4-29 MAGNUM XL 54, Scan-Width, Camera D

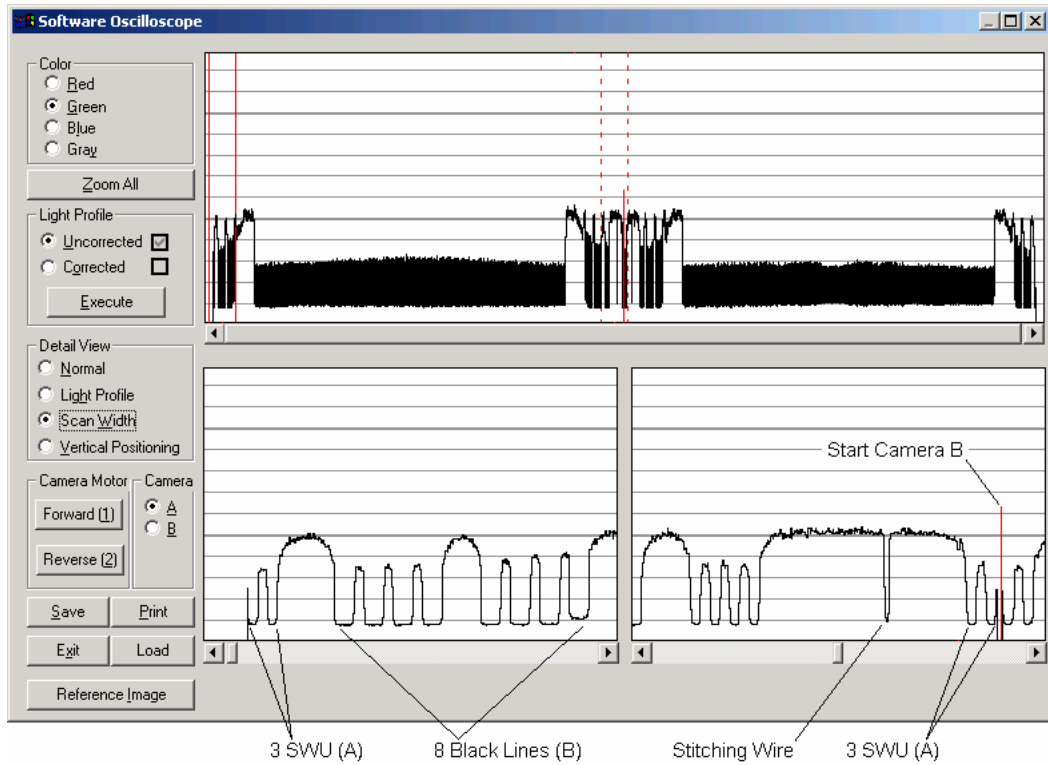

Fig. 4-30 COUGAR Tx 36, CHAMELEON Tx 36, PREMIER Tx 36
Scan-Width , Camera A

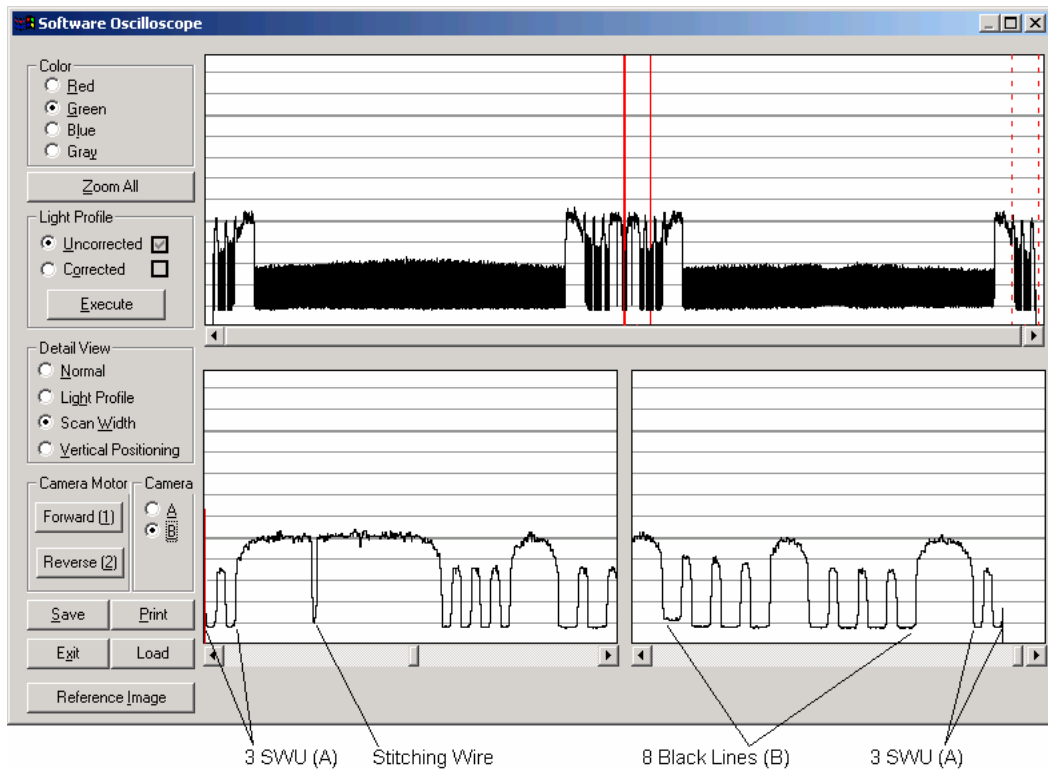

Fig. 4-31 COUGAR Tx 36, CHAMELEON Tx 36, PREMIER Tx 36
Scan-Width, Camera B

4.2.6 Check and Adjustment of CCD-Centering

Images of the CCD-Centering adjustments are shown in:

- Fig. 4-32 COUGAR 25, CHAMELEON 25, CCD-Centering and Vertical Positioning, page 114
 Fig. 4-33 COUGAR 36, CHAMELEON 36, PREMIER 36, CCD-Centering and Vertical Positioning (A), page 115
 Fig. 4-34 COUGAR 36, CHAMELEON 36, PREMIER 36, CCD-Centering and Vertical Positioning (B), page 115
 Fig. 4-35 CHROMA Tx 40, CRYSTAL Tx 40, CCD-Centering and Vertical Positioning (A), page 116
 Fig. 4-36 CHROMA Tx 40, CRYSTAL Tx 40, CCD-Centering and Vertical Positioning (B), page 116
 Fig. 4-37 CHROMA Tx 40, CRYSTAL Tx 40, CCD-Centering and Vertical Positioning (C), page 117
 Fig. 4-38 MAGNUM XL 54, CCD-Centering and Vertical Positioning (A), page 118
 Fig. 4-39 MAGNUM XL 54, CCD-Centering and Vertical Positioning (B), page 118
 Fig. 4-40 MAGNUM XL 54, CCD-Centering and Vertical Positioning (C), page 119
 Fig. 4-41 MAGNUM XL 54, CCD-Centering and Vertical Positioning (D), page 119
 Fig. 4-42 COUGAR Tx 36, CHAMELEON Tx 36, PREMIER Tx 36, CCD-Centering and Vertical Positioning (A), page 120
 Fig. 4-43 COUGAR Tx 36, CHAMELEON Tx 36, PREMIER Tx 36, CCD-Centering and Vertical Positioning (B)120, page 120

The aim of this adjustment is to position the field of vision of the CCD-Camera symmetrically with respect to the Scan-Width Adjustment Patterns.

The Black Lines and White Spaces of the Scan-Width Patterns should be distributed symmetrically with the following number of Scan-Width Units at both ends of the scanline:

Model	Optical Adjustment Pattern	No of Scan-Width Units, start	No of Scan-Width Units, end	Tolerance
COUGAR 25, CHAMELEON 25:	6779D105, sub-pattern A	3	3	± 1 SWU
COUGAR 36, CHAMELEON 36, PREMIER 36	6779D107, sub-pattern A	3	3	± 1 SWU
CHROMA Tx 40, CRYSTAL Tx 40	6779D102, sub-pattern A	3	3	± 1 SWU
MAGNUM XL 54	6779D130, sub-pattern A	3	3	± 1 SWU
COUGAR Tx 36, CHAMELEON Tx 36, PREMIER Tx 36	6779D127, sub-pattern A	3	3	± 1 SWU

The tolerance on the CCD-Centering means that the image may be shifted ± 1 SWU.

Note: The total number of Scan Width Units must be 6 ± 0.5 , see Section 4.2.5, page 99.

Adjustment Procedure

Place the Optical Adjustment Pattern (see table above) in the scan-area.

Align the Adjustment Pattern by pushing it sideways towards the Operator Panel and towards the rear of the scanner.

Start	SCANtest 6
Select	Test 9
Select	Uncorrected Light Profile
Press	Execute
Select	Green (Default)
Select	Detail View: Scan Width
Select	Camera

Loosen the three Camera Back-Plate fixing screws, see Fig. 4-44, page 121, the screws should be loosened just enough to allow the Camera Back-Plate to be moved.

Adjust the horizontal position of the Camera Back-Plate by means of the CCD Centering Lever until the oscilloscope image shows the correct number of Scan-Width Units of the actual sub-pattern at the start and at the end of the scanline.

Tighten the Camera Back-Plate fixing screws.

Interaction

Check Vertical Position.

After completing all camera adjustments, run Scanner Maintenance.

4.2.7 Check and Adjustment of Vertical Positioning

Images of the Vertical Positioning adjustments are shown in:

Fig. 4-32 COUGAR 25, CHAMELEON 25, CCD-Centering and Vertical Positioning, page 114

Fig. 4-33 COUGAR 36, CHAMELEON 36, PREMIER 36, CCD-Centering and Vertical Positioning (A), page 115

Fig. 4-34 COUGAR 36, CHAMELEON 36, PREMIER 36, CCD-Centering and Vertical Positioning (B), page 115

Fig. 4-35 CHROMA Tx 40, CRYSTAL Tx 40, CCD-Centering and Vertical Positioning (A), page 116

Fig. 4-36 CHROMA Tx 40, CRYSTAL Tx 40, CCD-Centering and Vertical Positioning (B), page 116

Fig. 4-37 CHROMA Tx 40, CRYSTAL Tx 40, CCD-Centering and Vertical Positioning (C), page 117

Fig. 4-38 MAGNUM XL 54, CCD-Centering and Vertical Positioning (A), page 118

Fig. 4-39 MAGNUM XL 54, CCD-Centering and Vertical Positioning (B), page 118

Fig. 4-40 MAGNUM XL 54, CCD-Centering and Vertical Positioning (C), page 119

Fig. 4-41 MAGNUM XL 54, CCD-Centering and Vertical Positioning (D), page 119

Fig. 4-42 COUGAR Tx 36, CHAMELEON Tx 36, PREMIER Tx 36, CCD-Centering and Vertical Positioning (A), page 120

Fig. 4-42 COUGAR Tx 36, CHAMELEON Tx 36, PREMIER Tx 36, CCD-Centering and Vertical Positioning (A), page 120

Fig. 4-43 COUGAR Tx 36, CHAMELEON Tx 36, PREMIER Tx 36, CCD-Centering and Vertical Positioning (B)120, page 120

The aim of this adjustment is to place the scanline in the correct “Vertical Position” within the scan-area, and to ensure that the scanline is “horizontal”.

The Vertical Positioning of the CCD-Cameras is based on the number of black lines of the Vertical Position Pattern that crosses the scanline (the Vertical Position Pattern is sub-pattern B of Fig. 4-45, page 122). The step height of the Black Lines in the Vertical Position Pattern is shown in the table following:

Model	Optical Adjustment Pattern	Step Height of Black Lines	Step Height 0 through 16 Black Lines
COUGAR 25, CHAMELEON 25	6779D105, sub-pattern B	0.15 mm	2.25 mm
COUGAR 36, CHAMELEON 36, PREMIER 36	6779D107, sub-pattern B	0.15 mm	2.25 mm
CHROMA Tx 40, CRYSTAL Tx 40	6779D102, sub-pattern B	0.15 mm	2.25 mm
MAGNUM XL 54	6779D130, sub-pattern B	0.15 mm	2.25 mm
COUGAR Tx 36, CHAMELEON Tx 36, PREMIER Tx 36	6779D127, sub-pattern B	0.15 mm	2.25 mm

The cameras are adjusted to 8 Black Lines of the Vertical Position Pattern at both ends of the scanlines.

Adjustment Procedure

Place the Optical Adjustment Pattern (see table above) in the scan-area.

Align the Adjustment Pattern by pushing it sideways towards the Operator Panel and towards the rear of the scanner.

Start	SCANtest 6
Select	Test 9
Select	Uncorrected Light Profile
Press	Execute
Select	Green (Default)
Select	Detail View: Vertical Positioning

Select Camera

Loosen the three Camera Back-Plate fixing screws. The screws should be loosened just enough to allow the Camera Back-Plate to be moved.

Adjust the Vertical Tilt Levers to get 8 Black Lines of the Vertical Position Patterns at both ends of the scanline, and at the same time maintain correct CCD-Centering.

If 8 Black Lines at both ends can not be obtained:

Set the Vertical Tilt Levers to their nominal positions, that is, horizontal position for the lever near the “connector end” of the camera board and vertical position for the other lever.

Loosen the lock screw for the Vertical Alignment Arm, see Fig. 4-44, page 121.

Adjust the Vertical Positioning Wheel to get 8 Black Lines at both ends of the scanline.

Tighten the Camera Back-Plate fixing screws, while maintaining the 8 Black Lines at both ends of the scanline.

The Vertical Alignment Arm should now be turned to parallel with the Back Plate of the camera.

1) The Vertical Alignment Arm may be turned by the Camera Motor using:

SCANtest 6, Test 9

Select Camera

Press Forward (1) to move the arm away from the Back Plate.

Press Reverse (2) to move the arm towards the Back Plate.

Note: The Vertical Alignment Arm moves very slowly when turned by the motor.

2) Alternatively, the Vertical Alignment Arm may be turned manually. Disconnect the motor from the connector on the CBE/CBF-Board and remove the two Motor Bracket fixing screws (see Fig. 4-44, page 121) to dismantle the Camera Motor and turn the pulley of the spindle manually.

When replacing: Make sure that the cylinder shaped nut on the spindle rests correctly in the cutout of the Vertical Alignment Arm. The Motor Bracket should be pushed to the uppermost position when tightening the fixing screws to ensure sufficient tension of the drive belt.

Tighten the lock screw for the Vertical Alignment Arm.

Tolerances:

The cameras should be adjusted to 8 Black Lines of Vertical Position Pattern at both ends of the scanlines.

For maintenance check the adjustment is considered acceptable if the number of Black Lines of the Green channel is within:

max. 12 Black Lines

min. 4 Black Lines

The sloping of a scanline, i.e. the difference in the number of Black Lines at the **start** and at the **end** of the scanline must be less than:

2 Black Lines

Interaction

After completing all camera adjustments, run Scanner Maintenance.

4.2.8 Final Check

As the above adjustments interact:

Check, and if necessary readjust steps 4.2.4 through 4.2.8

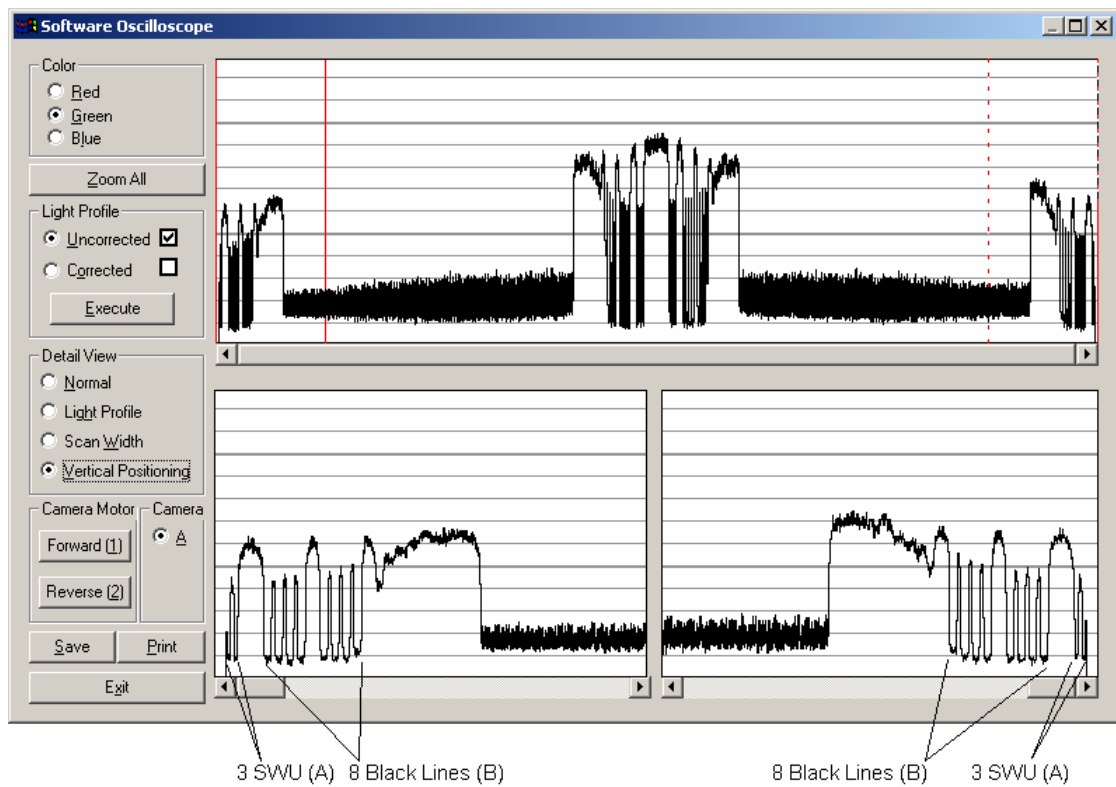

Fig. 4-32 COUGAR 25, CHAMELEON 25, CCD-Centering and Vertical Positioning

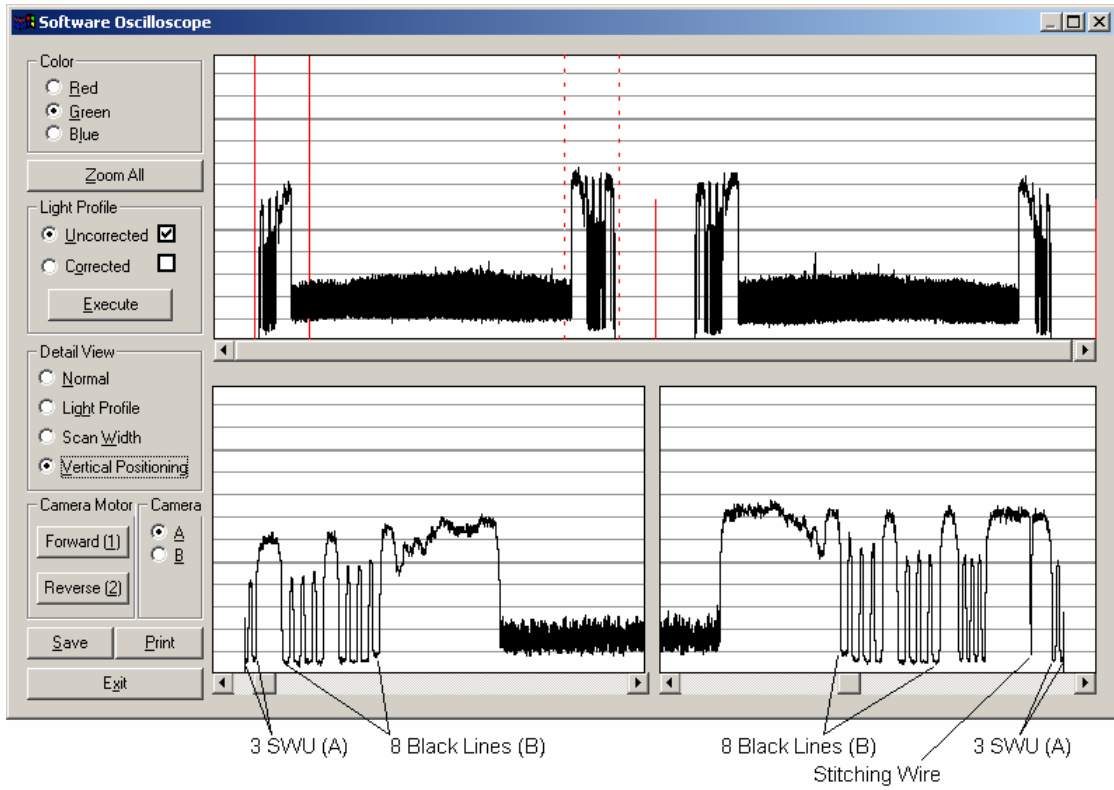

Fig. 4-33 COUGAR 36, CHAMELEON 36, PREMIER 36
 CCD-Centering and Vertical Positioning, Camera A

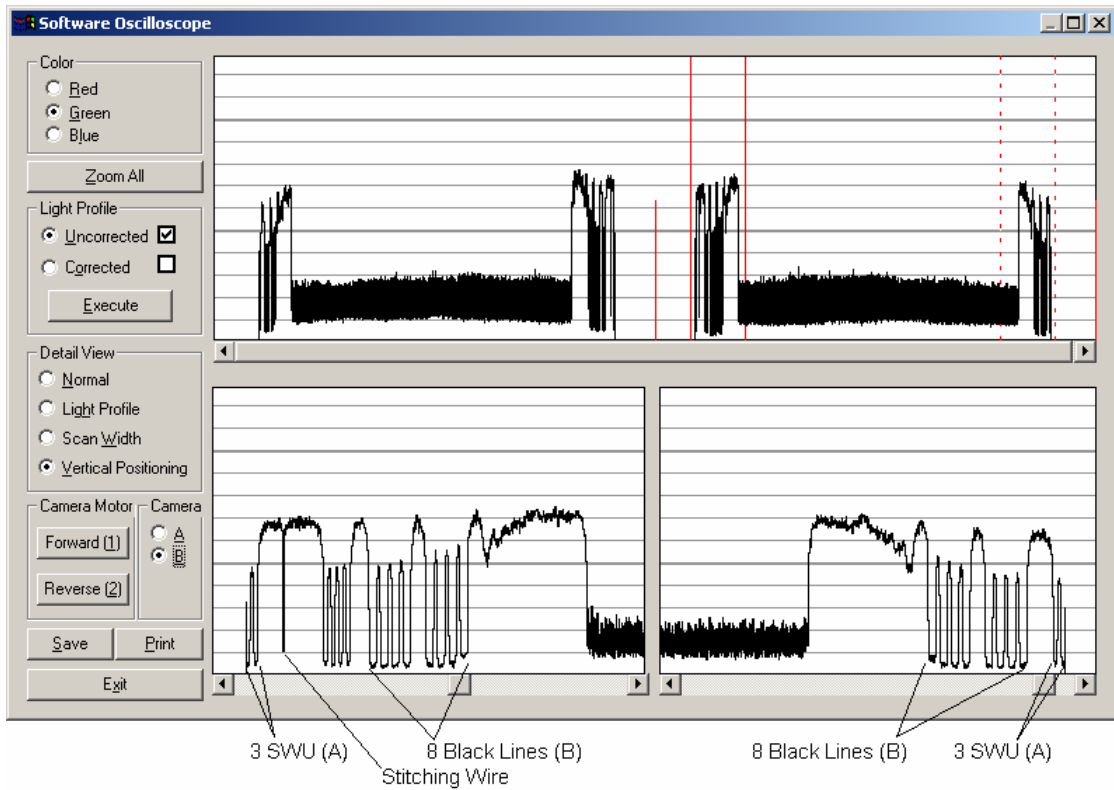

Fig. 4-34 COUGAR 36, CHAMELEON 36, PREMIER 36
 CCD-Centering and Vertical Positioning, Camera B

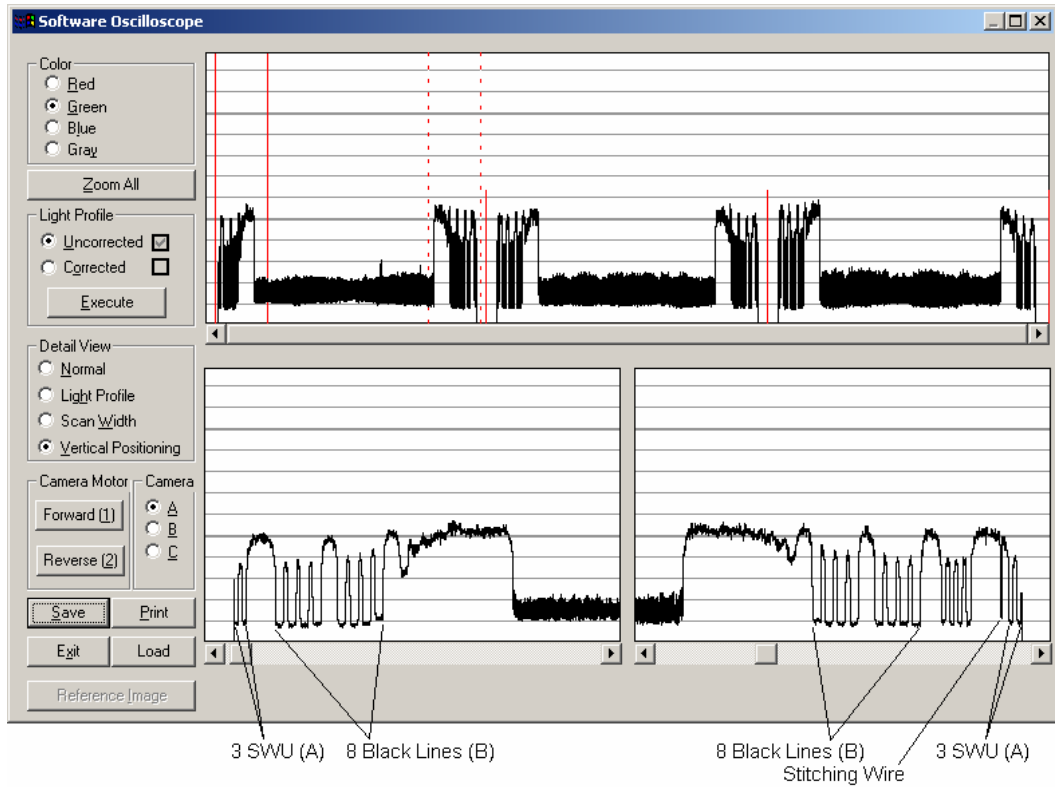

Fig. 4-35 CHROMA Tx 40, CRYSTAL Tx 40
 CCD-Centering and Vertical Positioning, Camera A

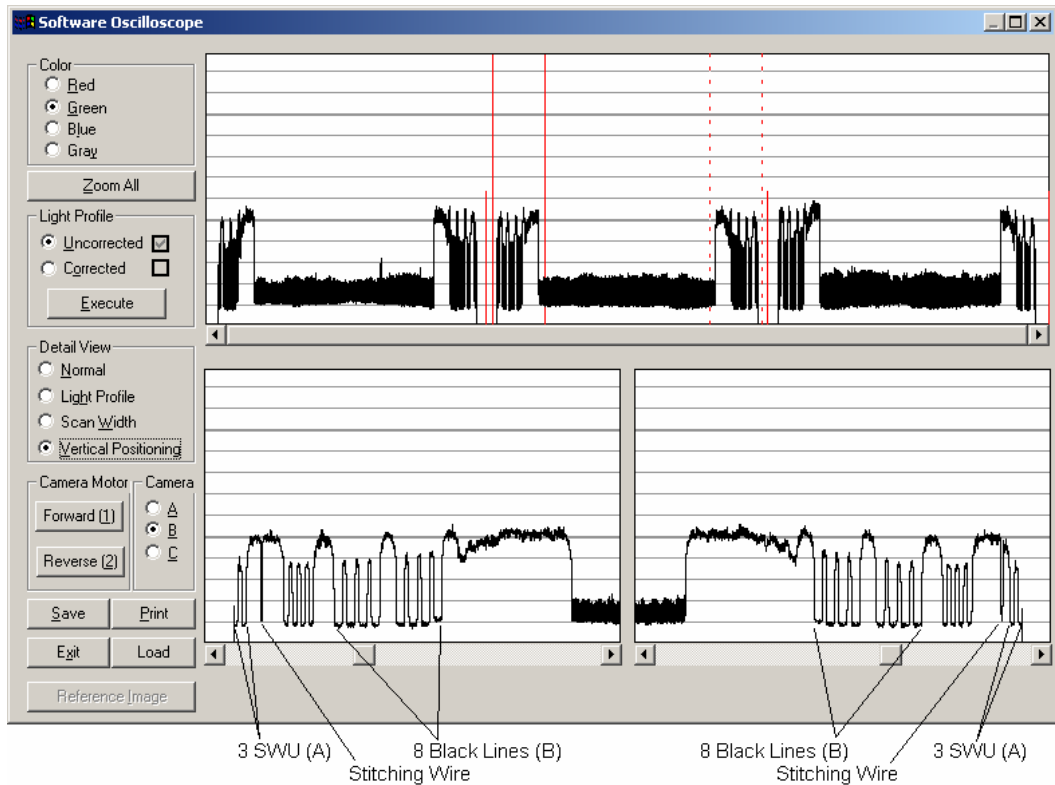

Fig. 4-36 CHROMA Tx 40, CRYSTAL Tx 40
 CCD-Centering and Vertical Positioning, Camera B

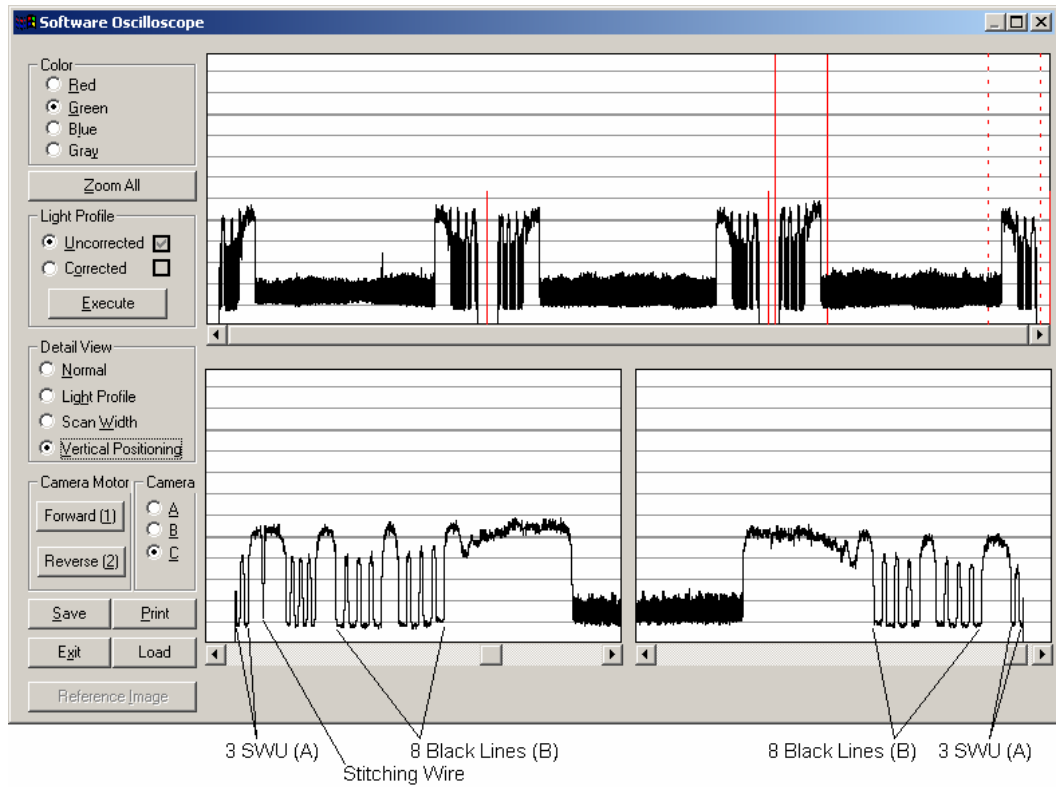

Fig. 4-37 CHROMA Tx 40, CRYSTAL Tx 40
 CCD-Centering and Vertical Positioning Camera C

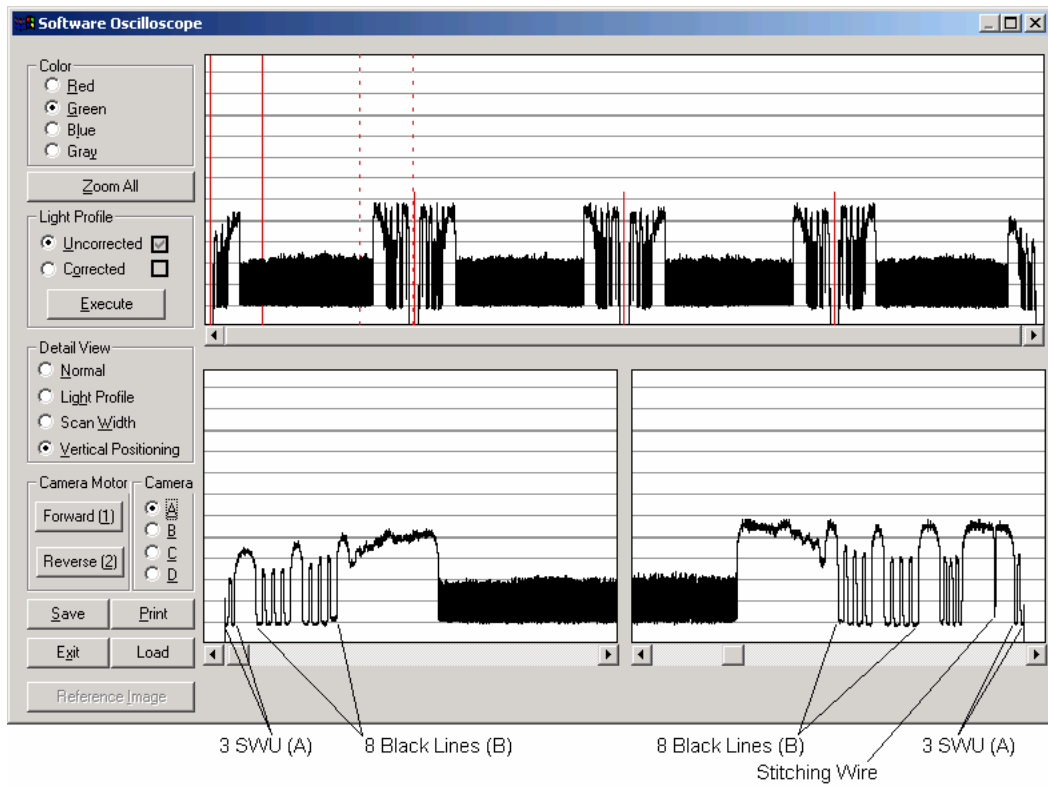

Fig. 4-38 MAGNUM XL 54
 CCD-Centering and Vertical Positioning, Camera A

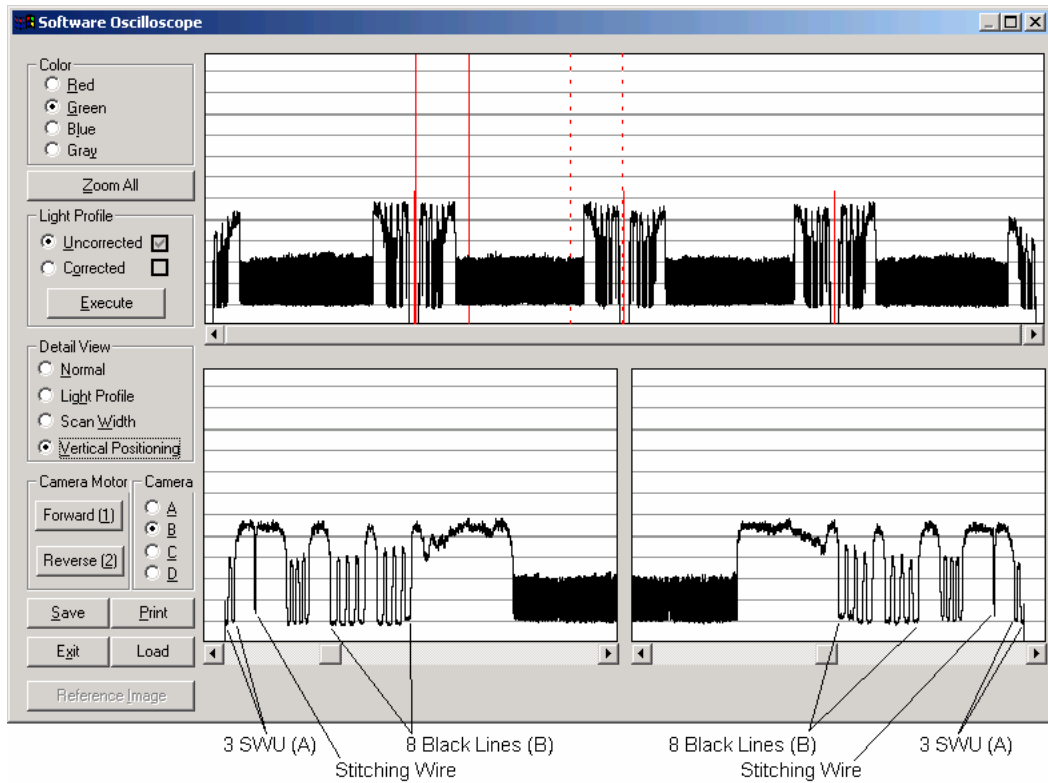

Fig. 4-39 MAGNUM XL 54
 CCD-Centering and Vertical Positioning, Camera B

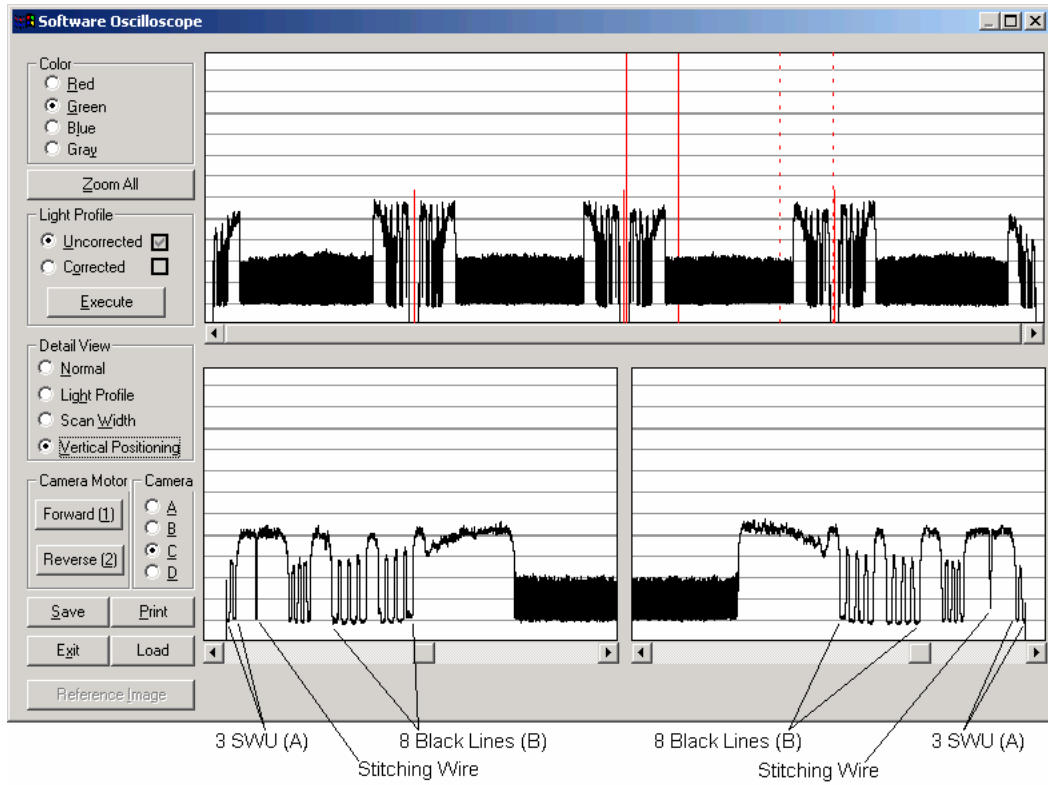

Fig. 4-40 MAGNUM XL 54
 CCD-Centering and Vertical Positioning, Camera C

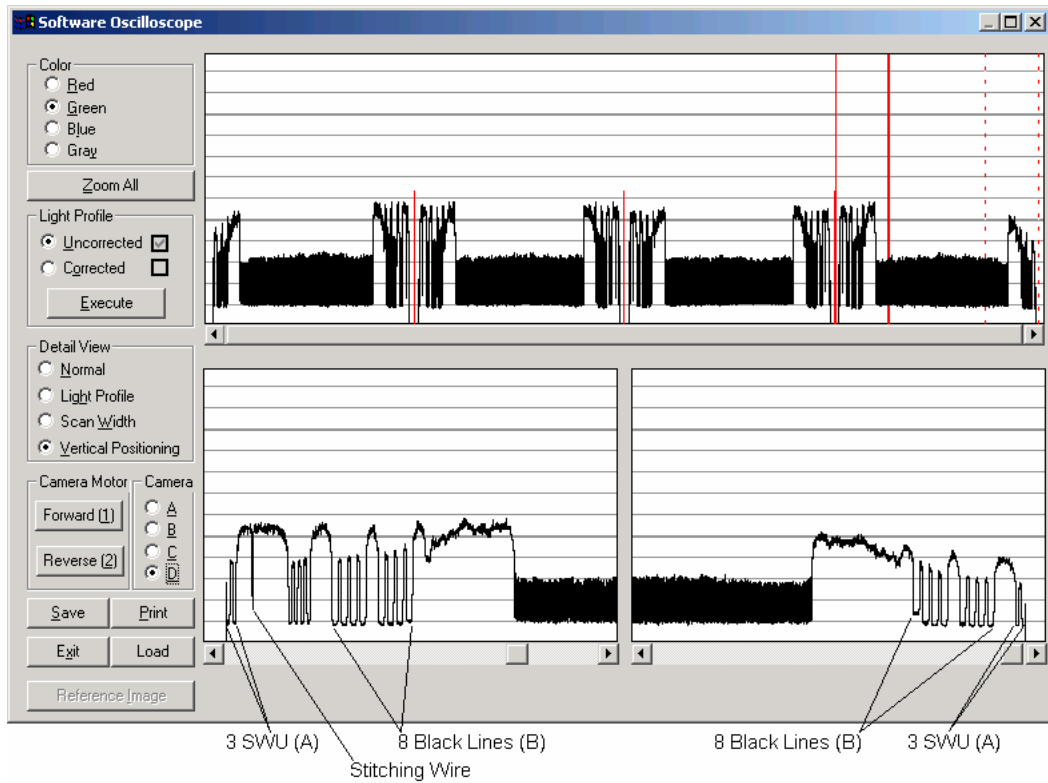

Fig. 4-41 MAGNUM XL 54
 CCD-Centering and Vertical Positioning, Camera D

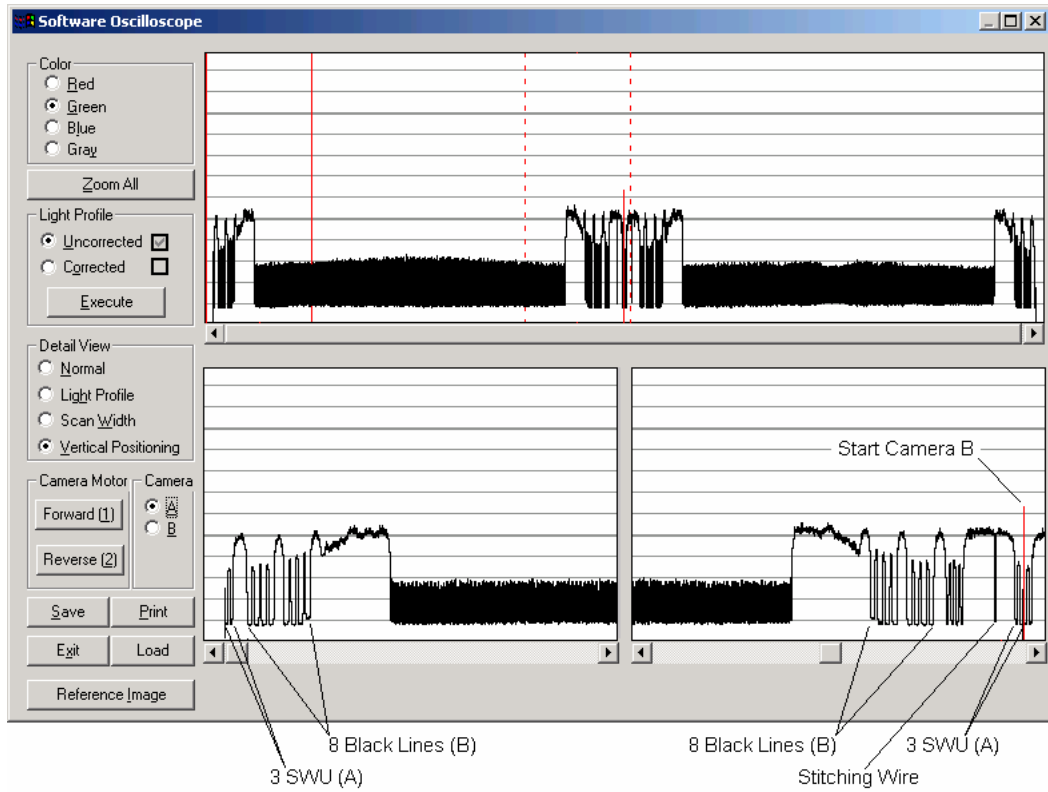

Fig. 4-42 COUGAR Tx 36, CHAMELEON Tx 36, PREMIER Tx 36
 CCD-Centering and Vertical Positioning, Camera A

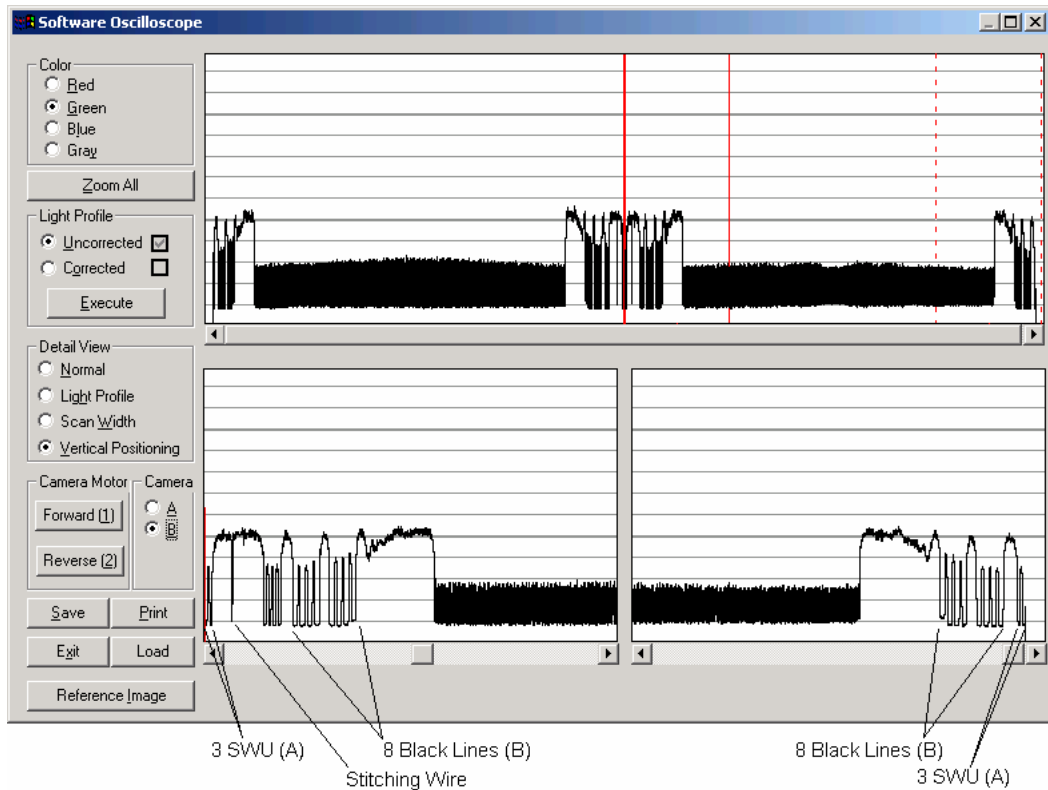

Fig. 4-43 COUGAR Tx 36, CHAMELEON Tx 36, PREMIER Tx 36
 CCD-Centering and Vertical Positioning, Camera B

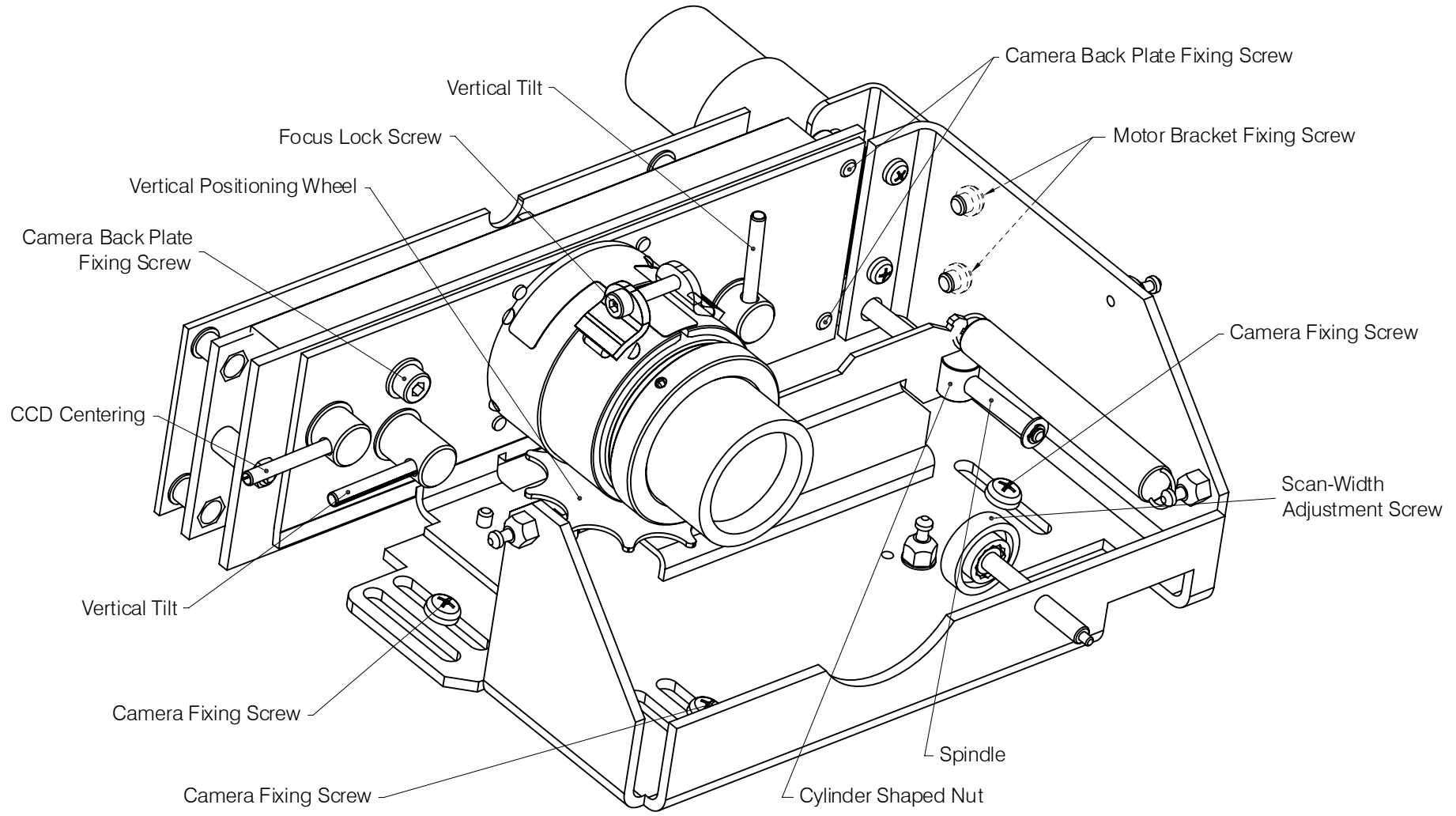
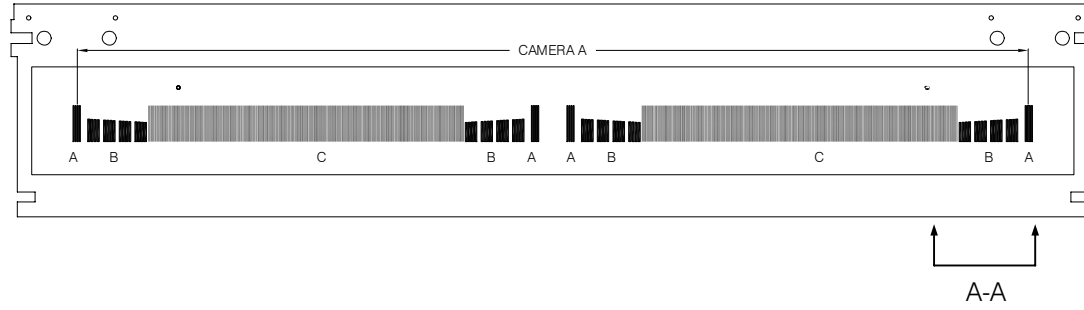
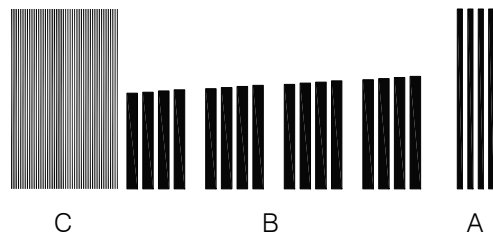

Fig. 4-44 CCD-Camera Overview (Adjustments)



- Sub-pattern A: Scan-Width Patterns
- Sub-pattern B: Vertical Position Patterns
- Sub-pattern C: Focus Pattern (used for coarse Focus adjustment)



Detail A-A

Fig. 4-45 Optical Adjustment Pattern, 25"

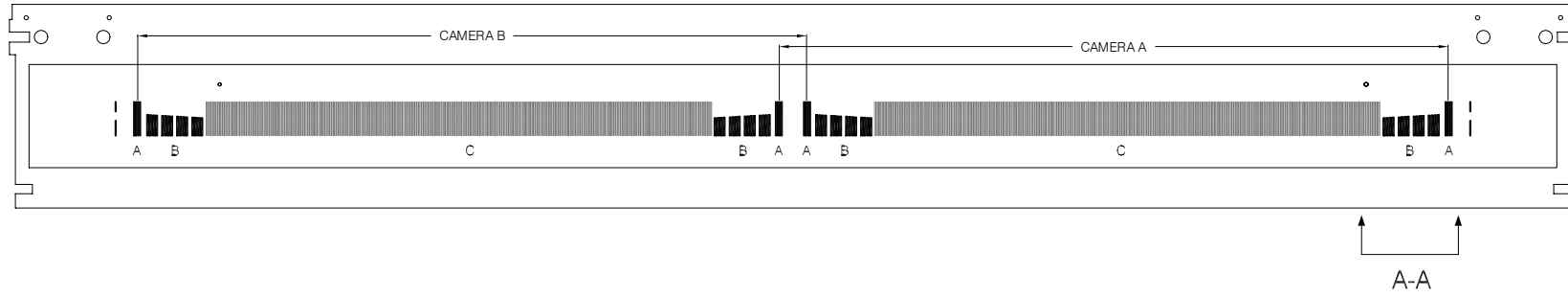

- Sub-pattern A: Scan-Width Patterns
- Sub-pattern B: Vertical Position Patterns
- Sub-pattern C: Focus Pattern (used for coarse Focus adjustment)

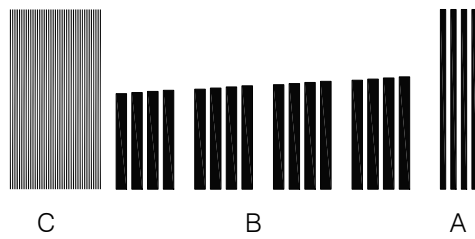

Detail A-A

Fig. 4-46 Optical Adjustment Pattern, 2 Camera, 36"

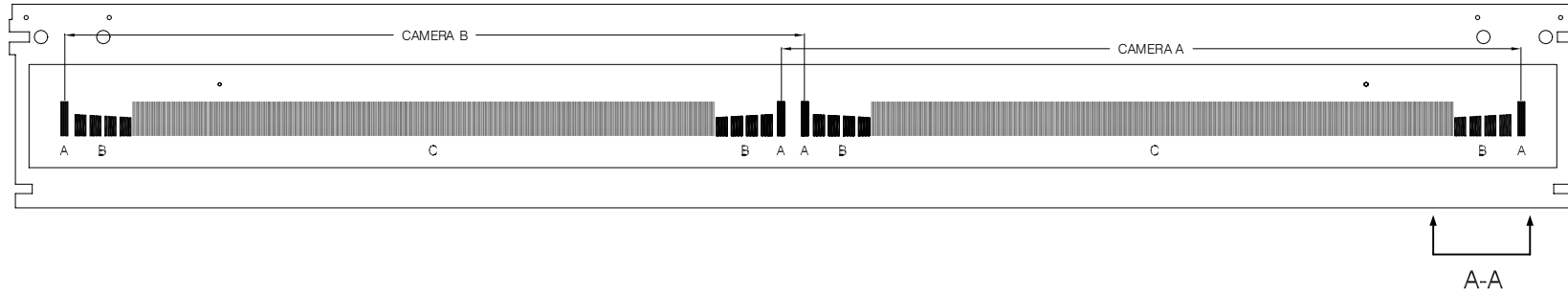

- Sub-pattern A: Scan-Width Patterns
- Sub-pattern B: Vertical Position Patterns
- Sub-pattern C: Focus Pattern (used for coarse Focus adjustment)

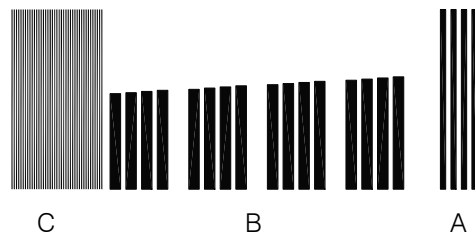

Detail A-A

Fig. 4-47 Optical Adjustment Pattern, 2 Camera, 40"



- Sub-pattern A: Scan-Width Patterns
- Sub-pattern B: Vertical Position Patterns
- Sub-pattern C: Focus Pattern (used for coarse Focus adjustment)

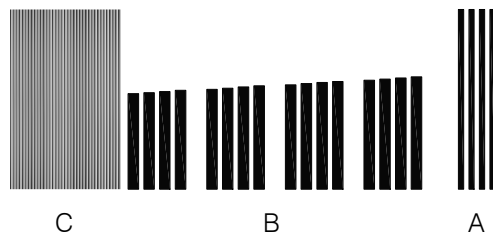

Detail A-A

Fig. 4-48 Optical Adjustment Pattern, 3 Camera, 40"

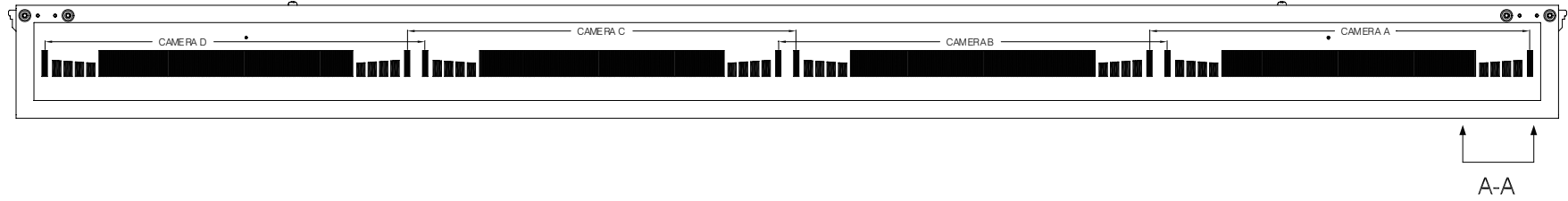

- Sub-pattern A: Scan-Width Patterns
- Sub-pattern B: Vertical Position Patterns
- Sub-pattern C: Focus Pattern (used for coarse Focus adjustment)

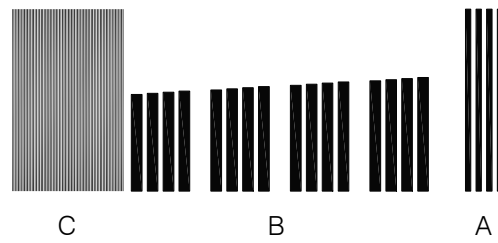

Detail A-A

Fig. 4-49 Optical Adjustment Pattern, 4 Camera, 54"

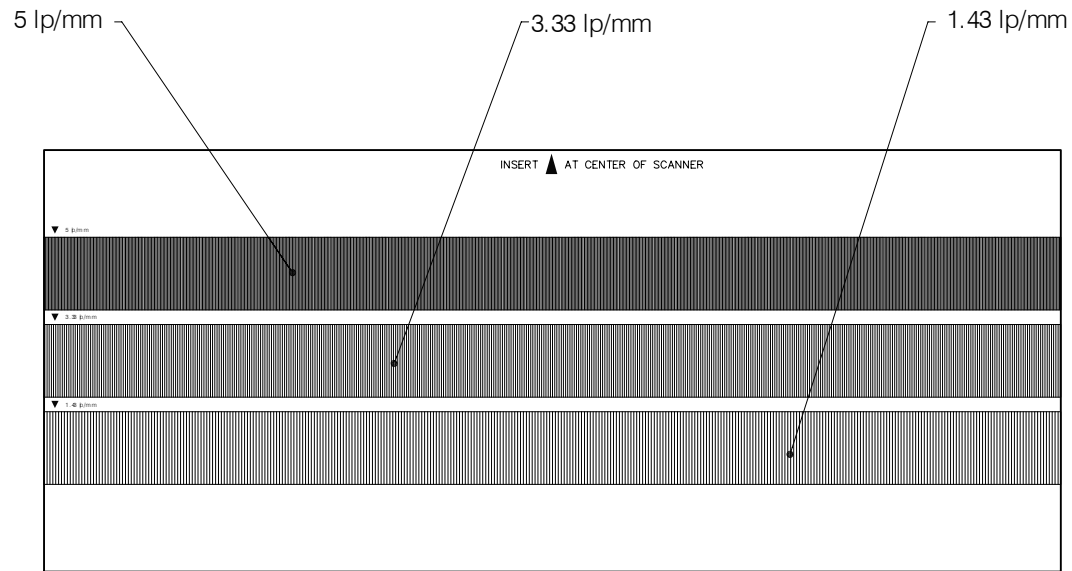

Upper Pattern: 0.1mm black lines with 0.1mm spacing (5 lp/mm)

Center Pattern: 0.15mm black lines with 0.15mm spacing (3.33 lp/mm)

Lower Pattern: 0.35mm black lines with 0.35mm spacing (1.43 lp/mm)

Fig. 4-50 Focus Pattern, 25"

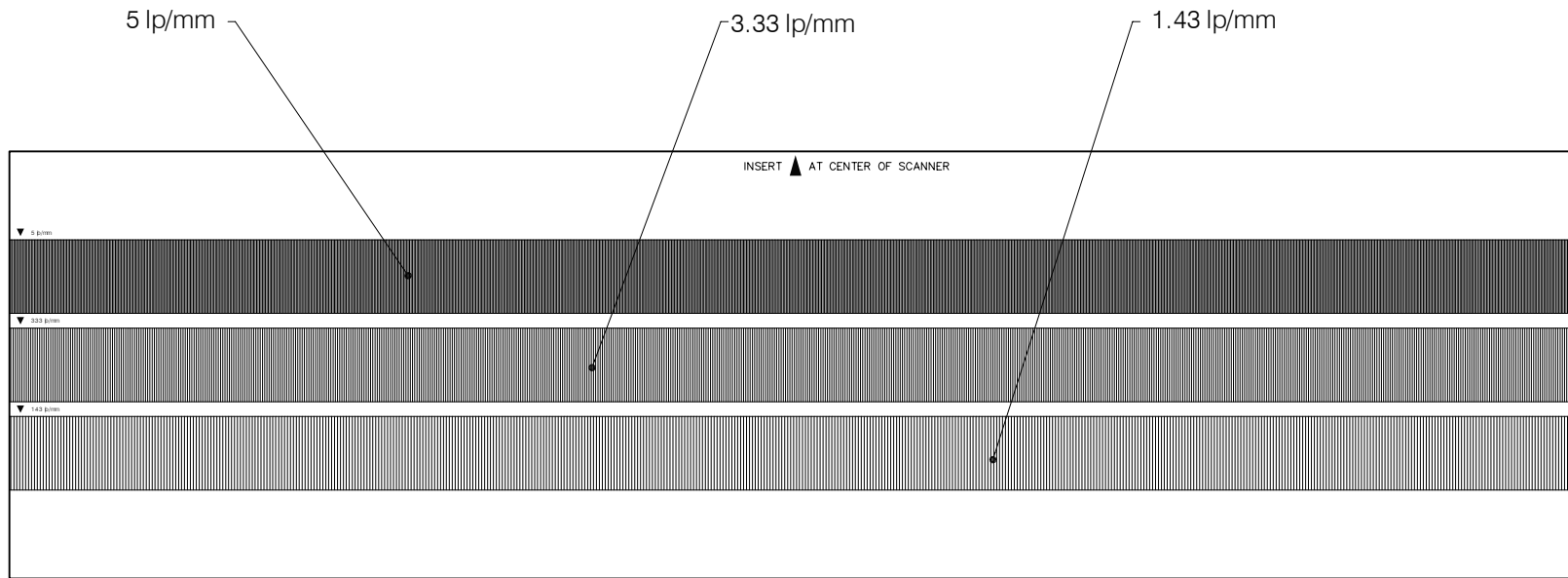

Upper Pattern: 0.1mm black lines with 0.1mm spacing (5 lp/mm)

Center Pattern: 0.15mm black lines with 0.15mm spacing (3.33 lp/mm)

Lower Pattern: 0.35mm black lines with 0.35mm spacing (1.43 lp/mm)

Fig. 4-51 Focus Pattern, 40"

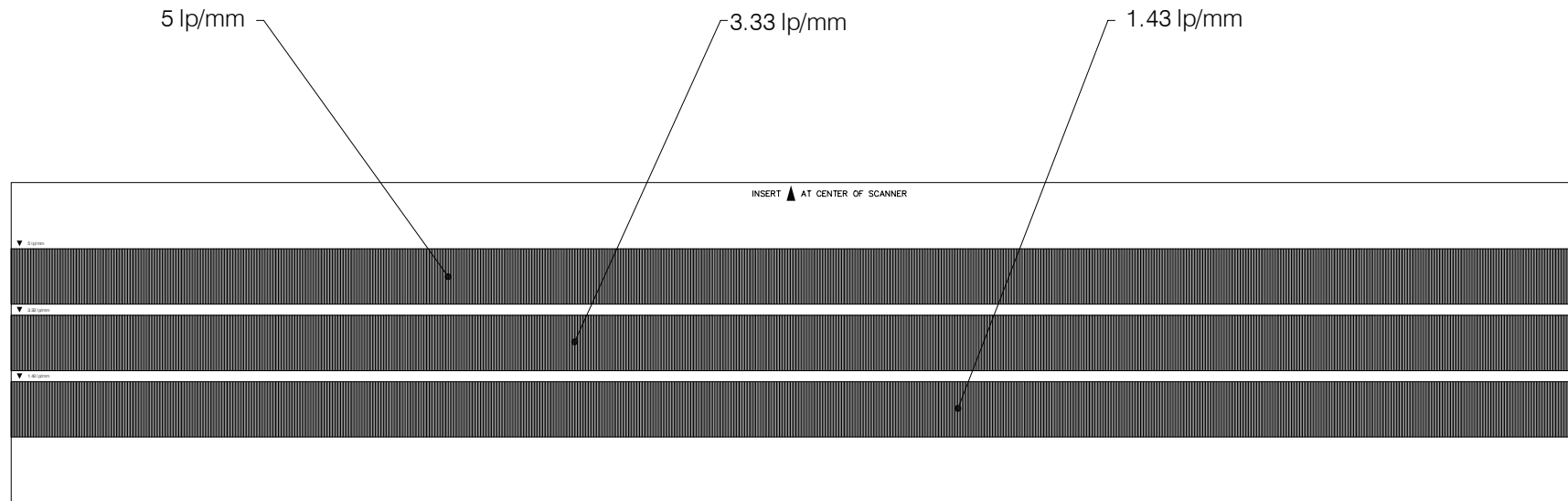

Upper Pattern: 0.1mm black lines with 0.1mm spacing (5 lp/mm)

Center Pattern: 0.15mm black lines with 0.15mm spacing (3.33 lp/mm)

Lower Pattern: 0.35mm black lines with 0.35mm spacing (1.43 lp/mm)

Fig. 4-52 Focus Pattern, 54"

5. Vertical Alignment and Horizontal Stitching

5.1 Principle of Stitching

See Fig. 5-1 Principle of Stitching, page 131.

The following description refers to Stitching of Camera A and Camera B, but it applies for other adjacent cameras as well.

As shown in the Scanner Block Diagrams in Section 2.2 the fields of vision of adjacent cameras overlap.

The Stitching Wire is placed within the 'overlapped' area and is seen by both CCD-Cameras. The scanned image of the Stitching Wire is used to determine the virtual end point of Scanline A and the virtual start point of Scanline B.

The pixel stream from Camera A is stopped N_A pixels before the image of the Stitching Wire, and the pixel stream from Camera B is started N_B pixels after the image of the Stitching Wire. As illustrated by Fig. 5-1, page 131, the Stitching depends on the distance between the Stitching Wire and the Original as well as on the size of N_A and N_B .

Whenever the scanner is idle, the Stitching is continuously updated and corrected for relative changes in the position of the Stitching Wire parallel to the glass plate. If the position of the Stitching Wire is changed perpendicular to the glass plate, the Stitch values, which are stored in Flash Memory on the SUC-Board, must be corrected using SCANtest 6, Test 11 or Scanner Maintenance.

The mounting of the Stitching Wire is shown in Fig. 5-2, page 132.

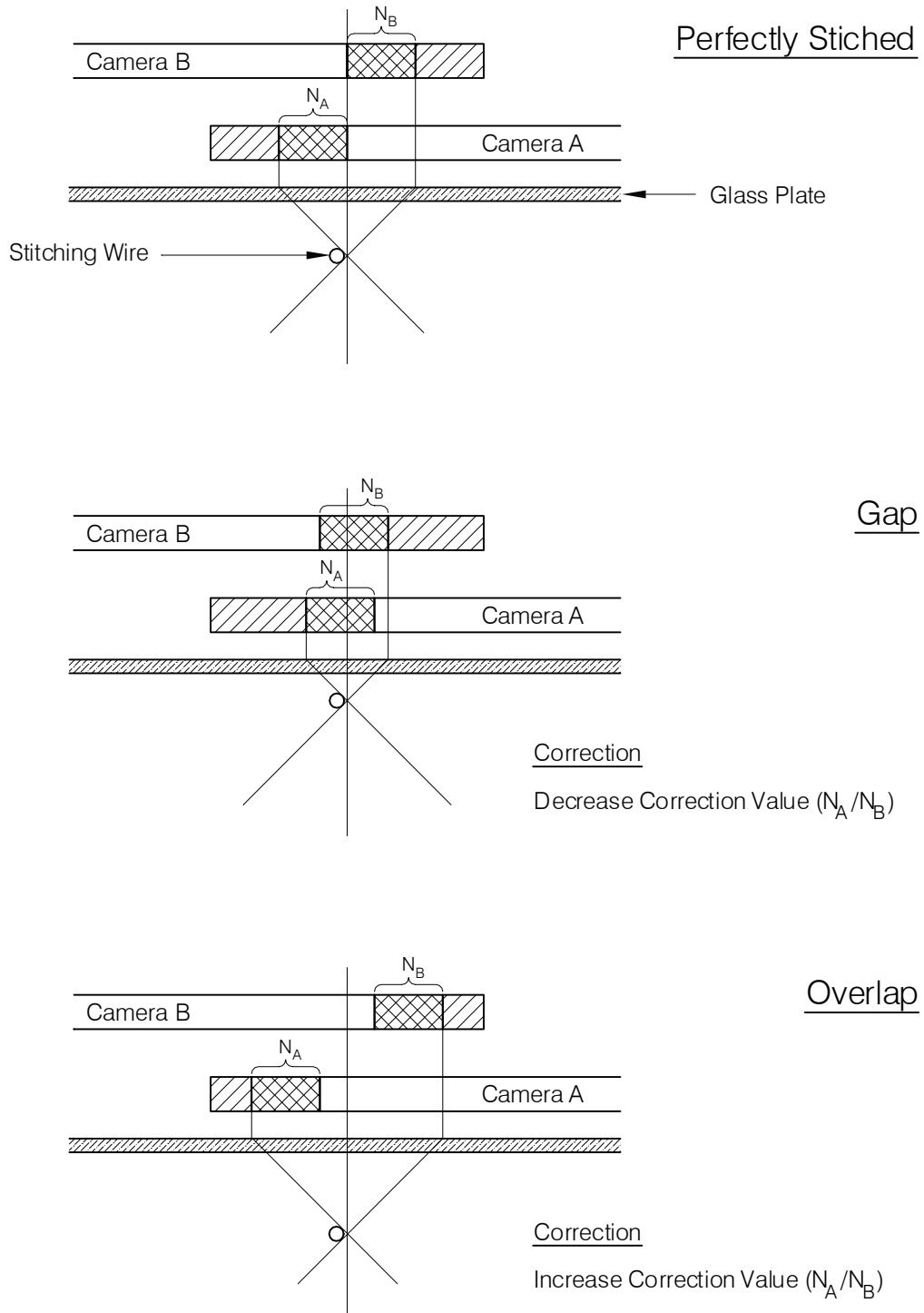

Fig. 5-1 Principle of Stitching

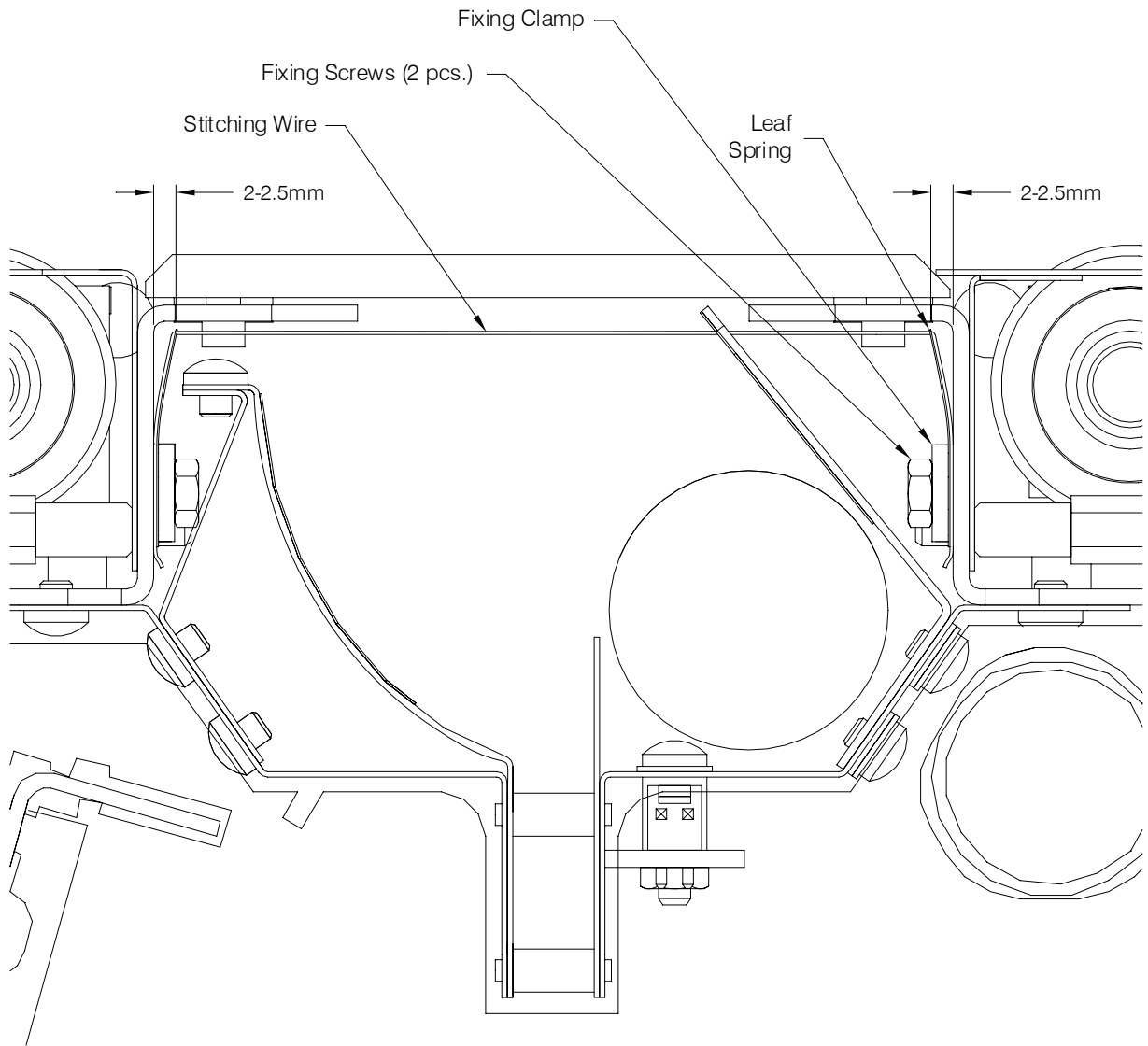

Fig. 5-2 Stitching Wire Mounting

5.2 Vertical Alignment and Horizontal Stitching Procedure

Stitching Images are shown in:

Fig. 5-3 COUGAR 36, CHAMELEON 36, PREMIER 36, Stitching Images, page 134

Fig. 5-4 CHROMA Tx 40, CRYSTAL Tx 40, Stitching Images A/B, page 135

Fig. 5-5 CHROMA Tx 40, CRYSTAL Tx 40, Stitching Images B/C, page 136

Fig. 5-6 MAGNUM XL 54, Stitching Images A/B, page 137

Fig. 5-7 MAGNUM XL 54, Stitching Images B/C, page 138

Fig. 5-8 MAGNUM XL 54, Stitching Images C/D, page 139

Fig. 5-9 COUGAR Tx 36, CHAMELEON Tx 36, PREMIER Tx 36, Stitching Images, page 140

Vertical Alignment and Horizontal Stitching are done automatically by running SCANtest 6, Test 11, using:

Model	SM Calibration Sheet
COUGAR 36, CHAMELEON 36, CHAMELEON PREMIER 36, CHROMA Tx 40, CRYSTAL Tx 40	p/n 6799D116
COUGAR Tx 36, CHAMELEON Tx 36, PREMIER Tx 36 MAGNUM XL 54	p/n 6799D165

The SM Calibration Sheets are shown in Fig. 6-2, page 144 and Fig. 6-3, page 145.

Adjustment Procedure

Start	SCANtest 6
Select	Test 11
Insert	SM Calibration Sheet
Select	Vertical Alignment
When done:	
Select	Horizontal Stitching

Note:

The automatic Vertical Alignment and Horizontal Stitching procedures are included in Scanner Maintenance and will always be performed as part of a complete Scanner Maintenance calibration.

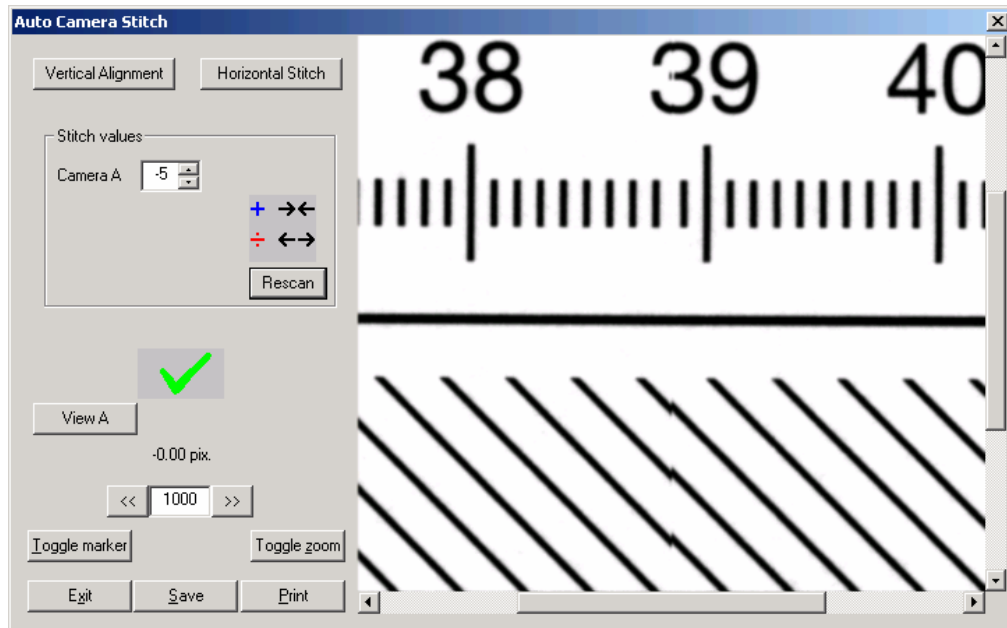

Camera A/B, Overlap
Corrected by Increasing Stitching Value

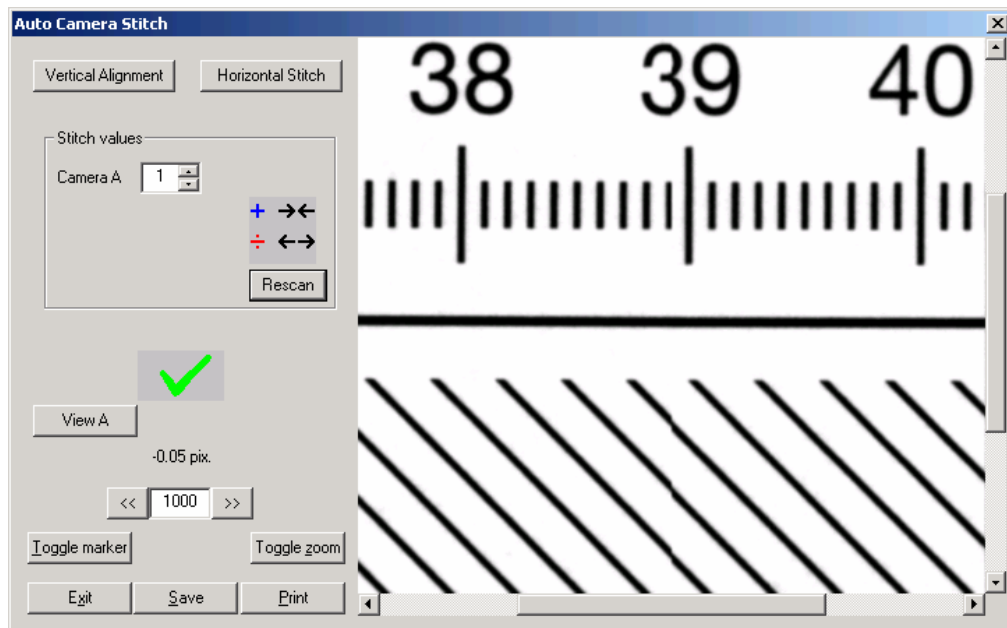

Camera A/B, Gap
Corrected by Decreasing Stitching Value

Fig. 5-3 COUGAR 36, CHAMELEON 36, PREMIER 36, Stitching Images

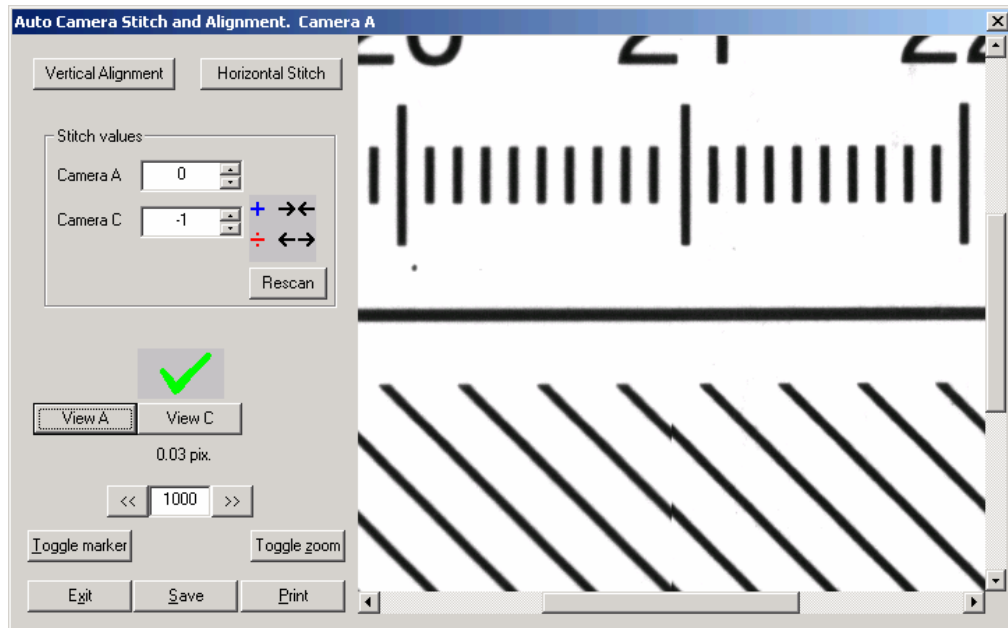

Camera A/B, Overlap
Corrected by Increasing Stitching Value

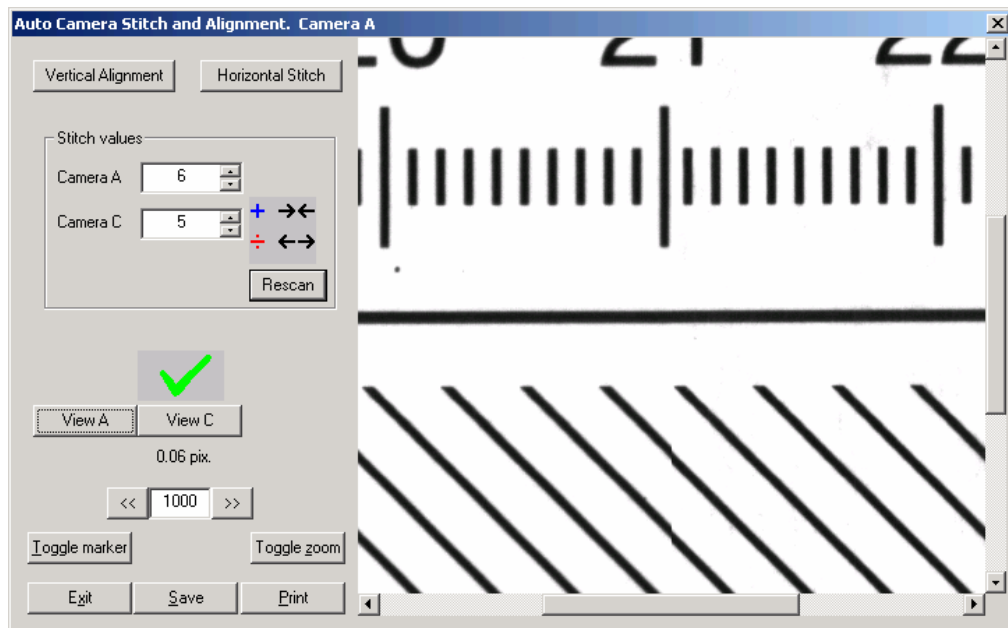

Camera A/B, Gap
Corrected by Decreasing Stitching Value

Fig. 5-4 CHROMA Tx 40, CRYSTAL Tx 40, Stitching Images A/B

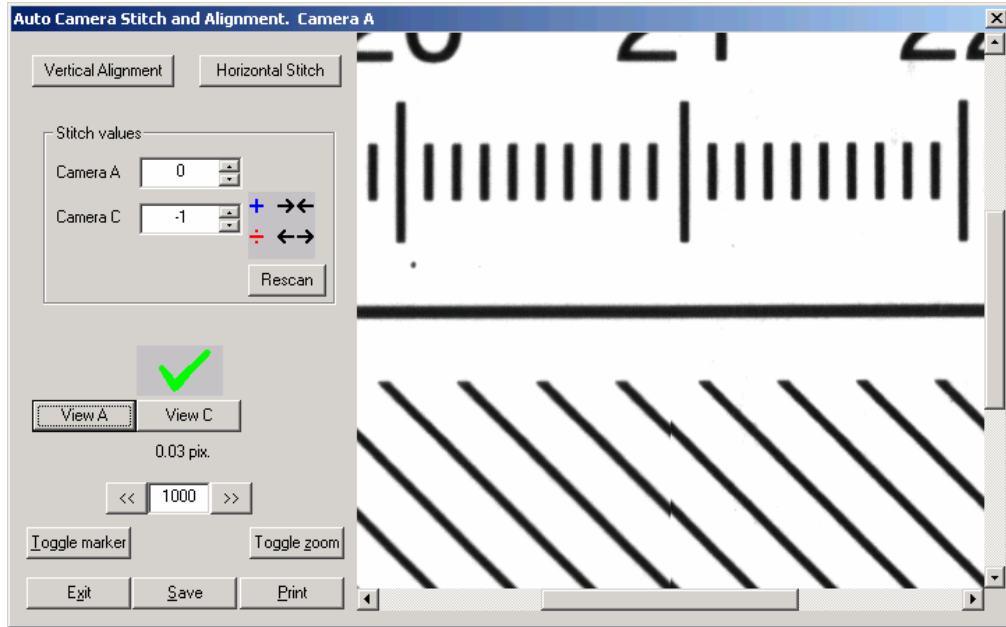

Camera B/C, Overlap
Corrected by Increasing Stitching Value

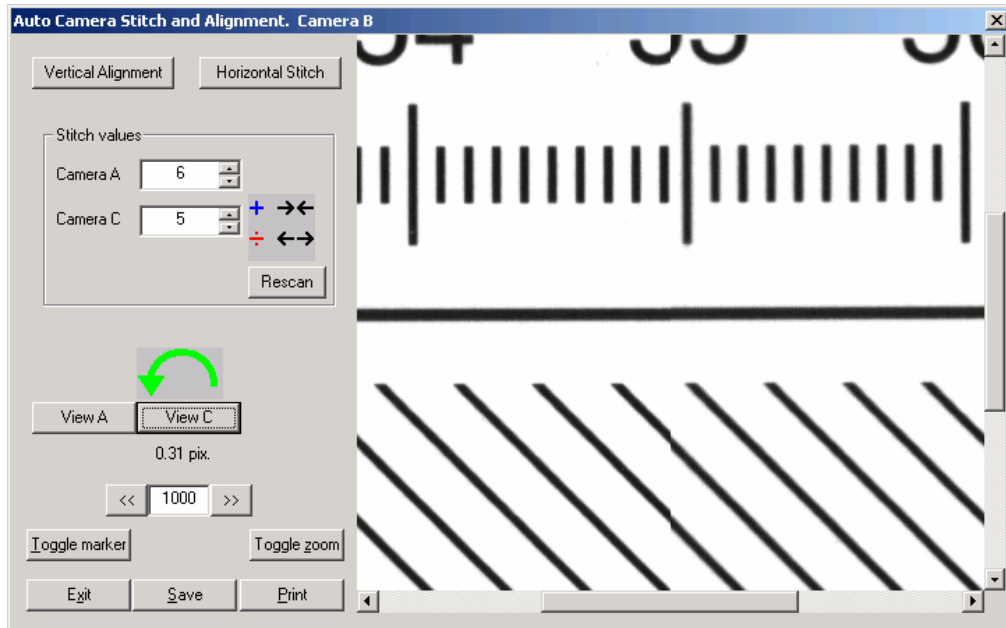

Camera B/C, Gap
Corrected by Decreasing Stitching Value

Fig. 5-5 CHROMA Tx 40, CRYSTAL Tx 40, Stitching Images B/C

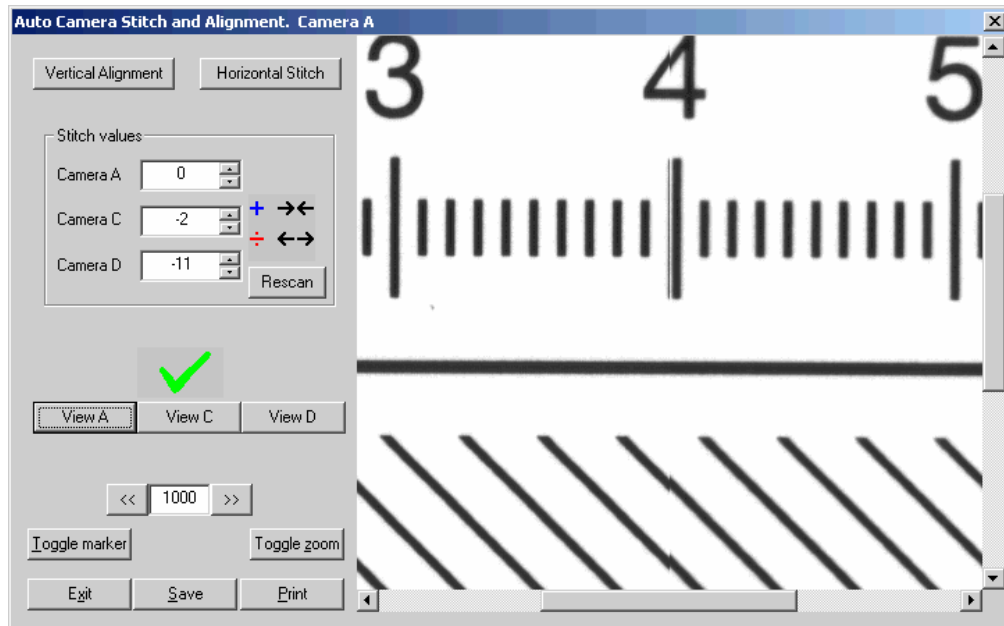

Camera A/B, Overlap
Corrected by Increasing Stitching Value

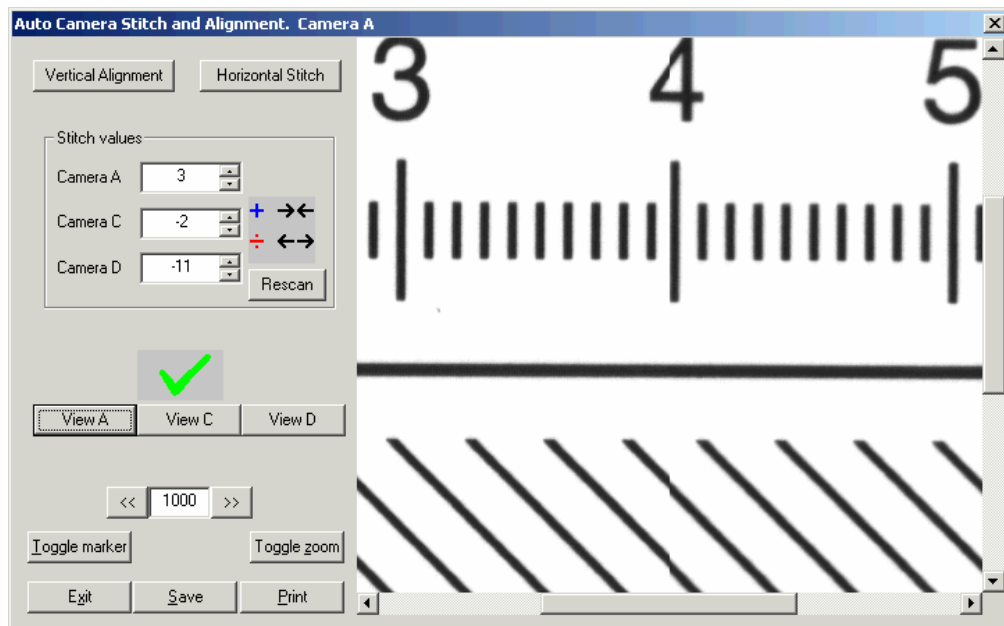

Camera A/B, Gap
Corrected by Decreasing Stitching Value

Fig. 5-6 MAGNUM XL 54, Stitching Images A/B

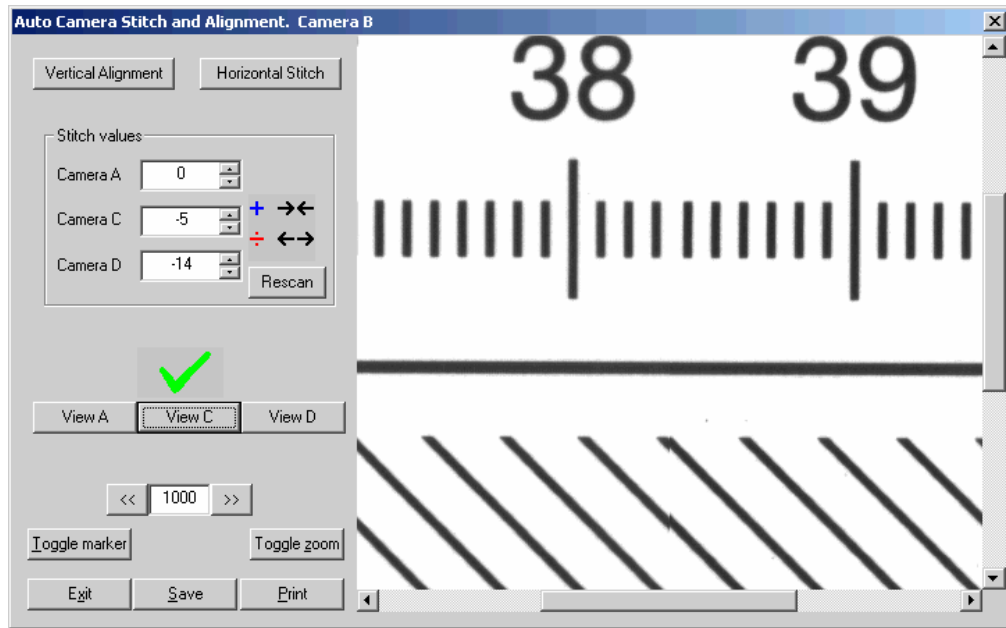

Camera B/C, Overlap
Corrected by Increasing Stitching Value

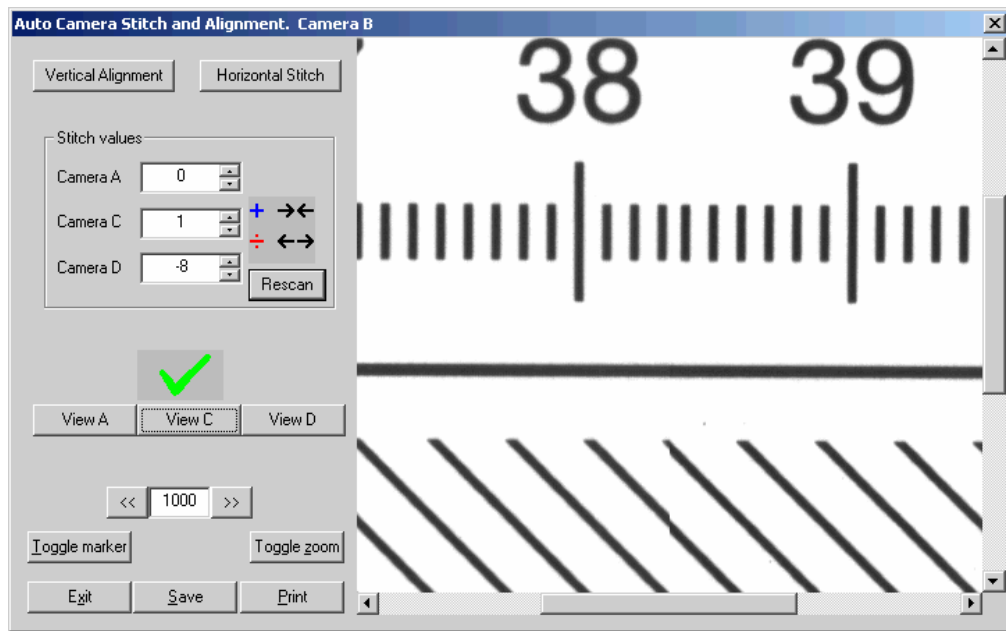

Camera B/C, Gap
Corrected by Decreasing Stitching Value

Fig. 5-7 MAGNUM XL 54, Stitching Images B/C

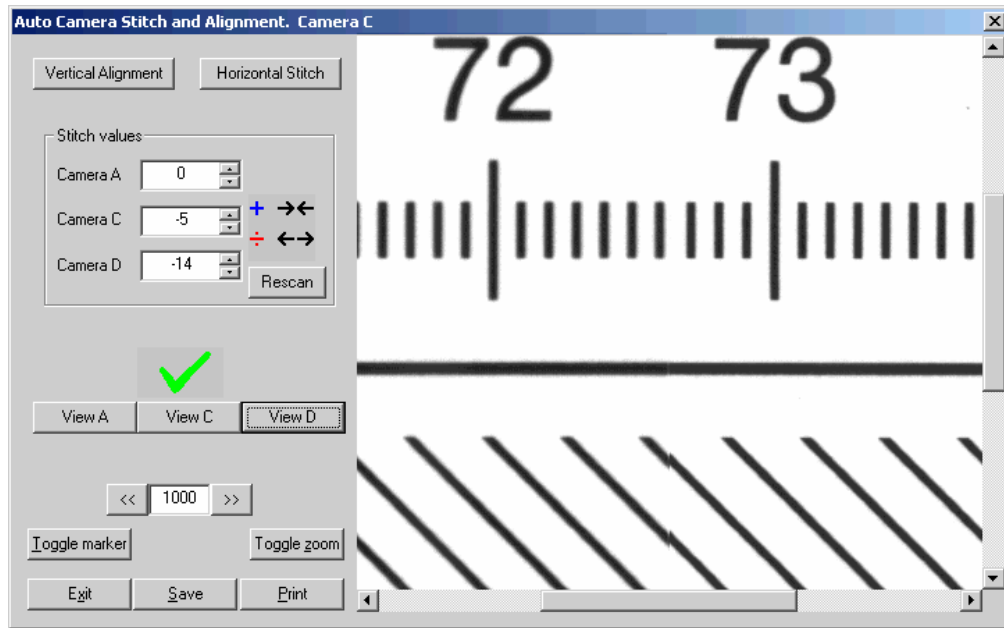

Camera C/D, Overlap
Corrected by Increasing Stitching Value

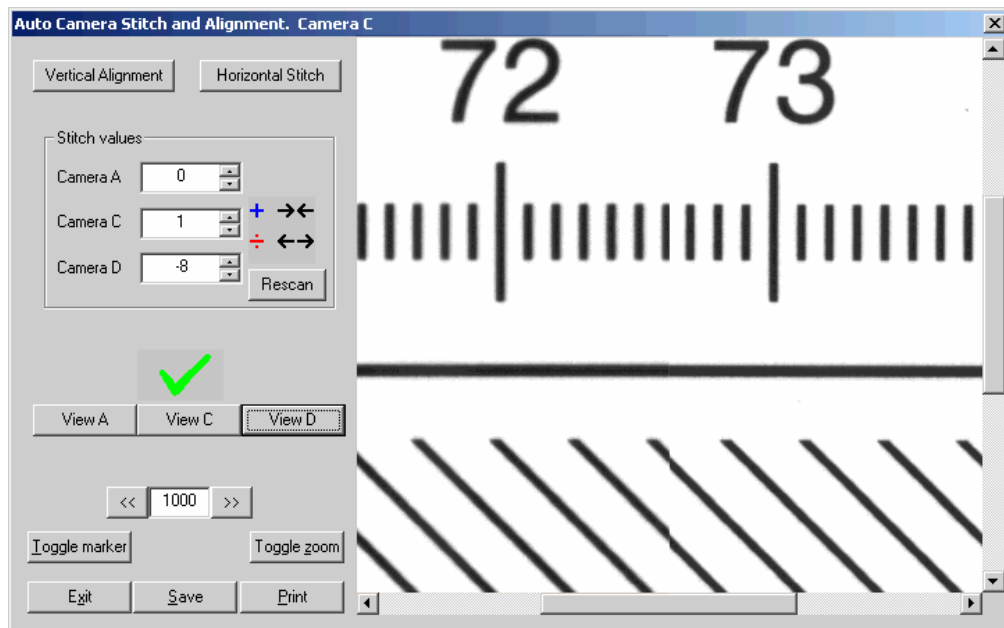

Camera C/D, Gap
Corrected by Decreasing Stitching Value

Fig. 5-8 MAGNUM XL 54, Stitching Images C/D

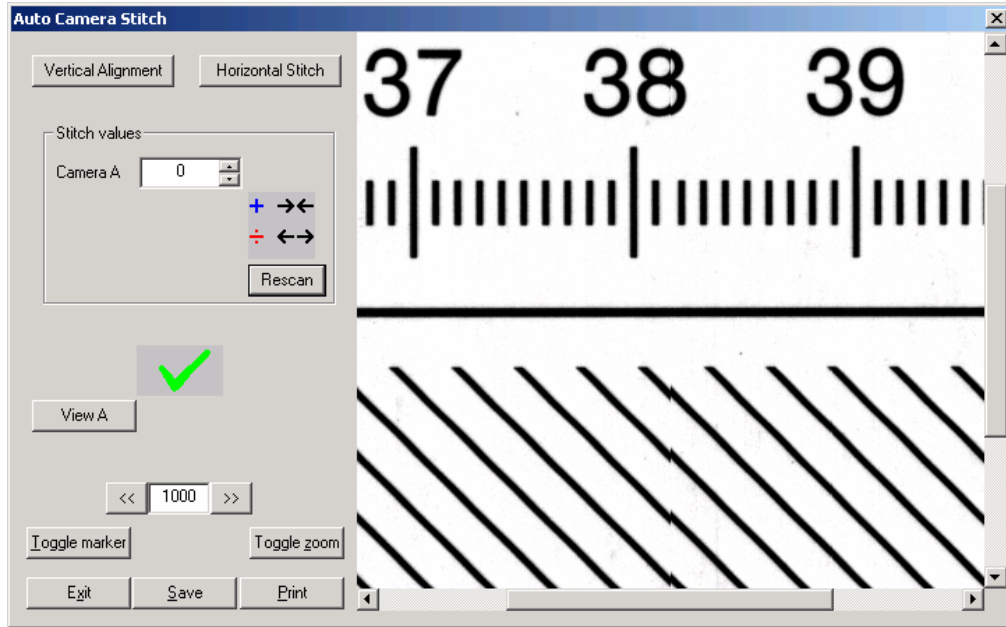

Camera A/B, Overlap
Corrected by Increasing Stitching Value

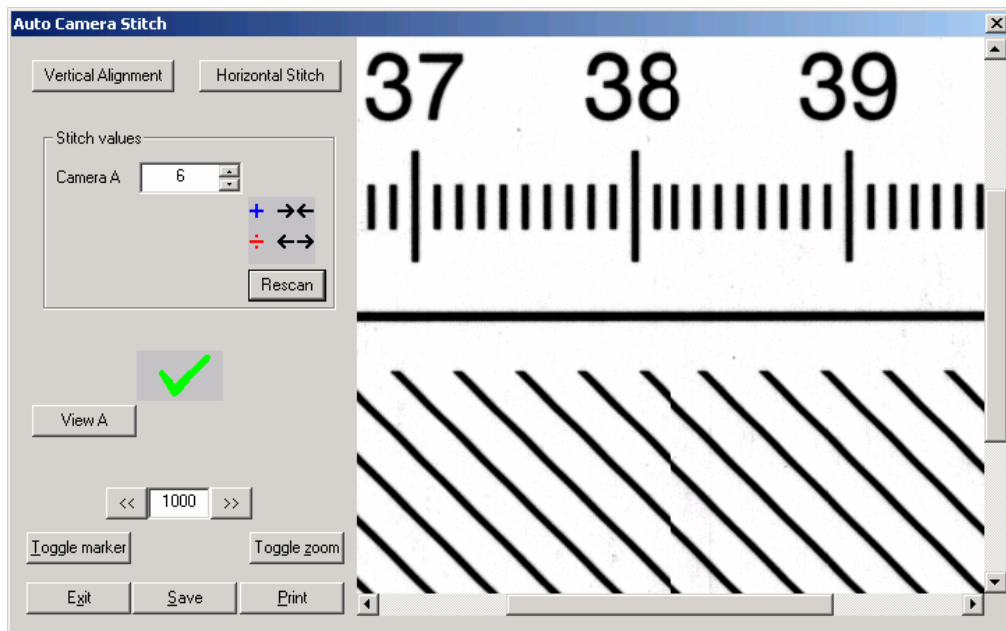

Camera A/B, Gap
Corrected by Decreasing Stitching Value

Fig. 5-9 COUGAR Tx 36, CHAMELEON Tx 36, PREMIER Tx 36, Stitching Images

6. General Maintenance

General Maintenance consists of the following steps:

- Cleaning of the scanning area.
- Checking the Fluorescent Lamp for signs of wear.
- Checking Lamp Driver Adjustment.
- Checking Camera Adjustments.
- Running Scanner Maintenance (Vertical Alignment, Stitching, and Calibrate Scanner).

For special service tools for General Maintenance, please refer to Chapter 12, page 193.

6.1 Step by Step Procedure for General Maintenance

6.1.1 Remove Top Cover

Disassembly and Assembly, see Chapter 8, page 156.

6.1.2 Cleaning of the Scanning Area

The following parts are cleaned using a soft lint-free cloth wetted with a mild cleaning detergent. Alternatively, the parts may be cleaned without the use of cleaning detergents by using a damp microfibre cleaning cloth (wet the cloth with water and wring until damp).

- The White Background Plate on the Original Guide Plate.
- Both sides of the Glass Plate.
 - On 2- and 3-camera scanners, be careful not to push the Stitching Wire (located under the Glass Plate) out of position.
 - Do not use solvents, as this may dissolve the paint used for the black masks on the glass plate.
- The Mirrors.
 - It is necessary to remove the Mirror Chassis, see Section 8.10, page 159, to get access to the mirrors for cleaning. The Camera Adjustment must be checked and if necessary readjusted after replacement of the Mirror Chassis.
 - Note: The mirrors are “out of focus” and small dust particles on the mirrors do therefore not deteriorate the scanning result.
- The Feed Rollers.
 - May be cleaned with a damp microfibre cleaning cloth.

6.1.3 Fluorescent Lamp

Check the fluorescent lamp for signs of wear, such as darkened ends or discolored (black stained) tube.

If there are signs of wear, the lamp should be replaced, see Section 9.4, page 162.

6.1.4 Check Lamp Driver Adjustment

Procedure, see Section 3.4.2, page 30.

Check and if necessary readjust the Lamp Driver.

6.1.5 Check CCD-Camera Adjustment

Procedure for Check and Adjustment, see Section 4.2, page 86.

If necessary re-adjust the cameras.

Caution: Before loosening any Camera Fixing screws or Focus Lock screws, make sure that all necessary Adjustment Patterns are available.

6.1.6 Replace Top Cover

Disassembly and Assembly, see Chapter 8, page 156.

6.1.7 Run Scanner Maintenance

When running Scanner Maintenance, the cameras are first automatically Vertically Aligned* and Horizontally Stitched*, next the scanner is Basic Calibrated using the White and Black Calibration Areas of the SM Calibration Sheet, and finally the scanner is Color Calibrated** using the IT8 Chart of the SM Calibration Sheet.

*) Vertical Alignment and Horizontal Stitching are not performed on 1-Camera scanners.

**) Color Calibration is performed on color scanners only.

The SM Calibration Sheets are shown on:

Fig. 6-1 SM Calibration Sheet, 25", page 143

Fig. 6-2 SM Calibration Sheet, 40", page 144

Fig. 6-3 SM Calibration Sheet, 54", page 145

To avoid vertical lines in the scanned image, the Glass Plate and the White Background Plate must be thoroughly cleaned before running Scanner Maintenance, see SCANtest 6, Test 20, Noise Test on page 174.

Procedure:

Start Scanner Maintenance

Insert SM Calibration Sheet

Follow the instructions given on the screen.

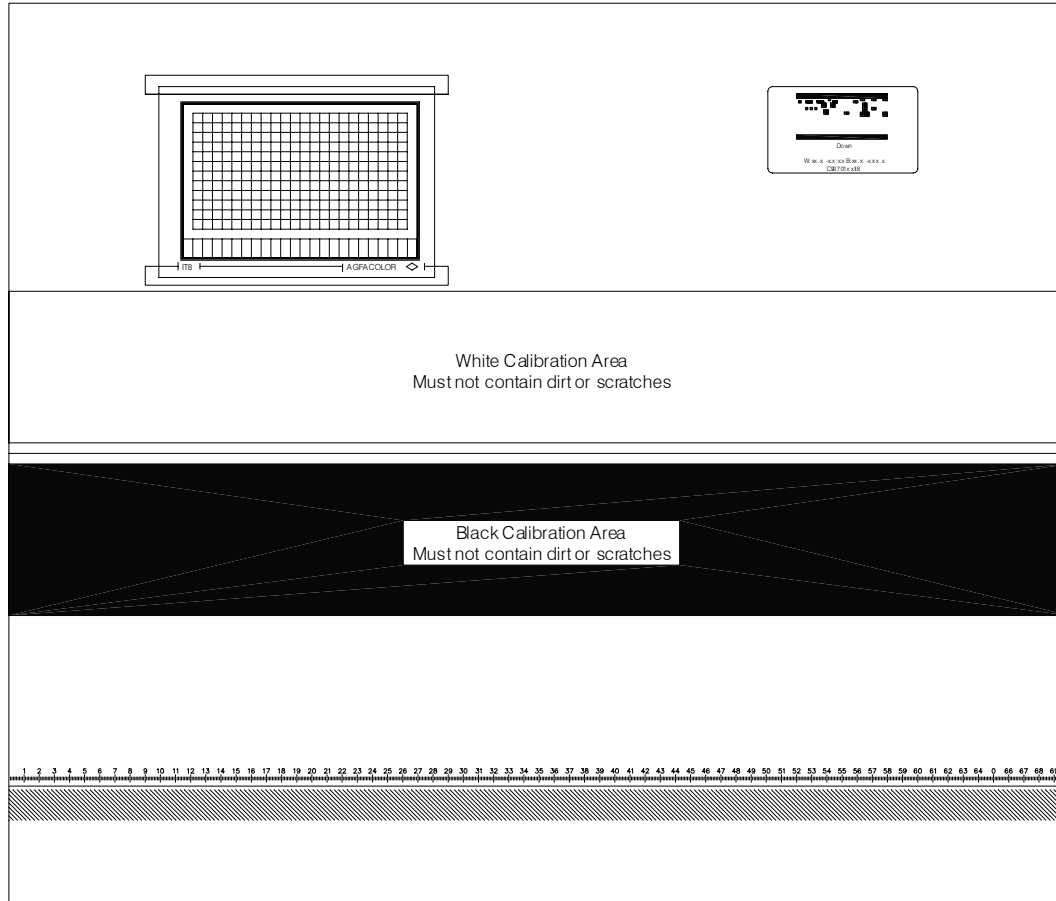

IT8-Sheet and
patterns faces
outwards when
folded



Fig. 6-1 SM Calibration Sheet, 25"

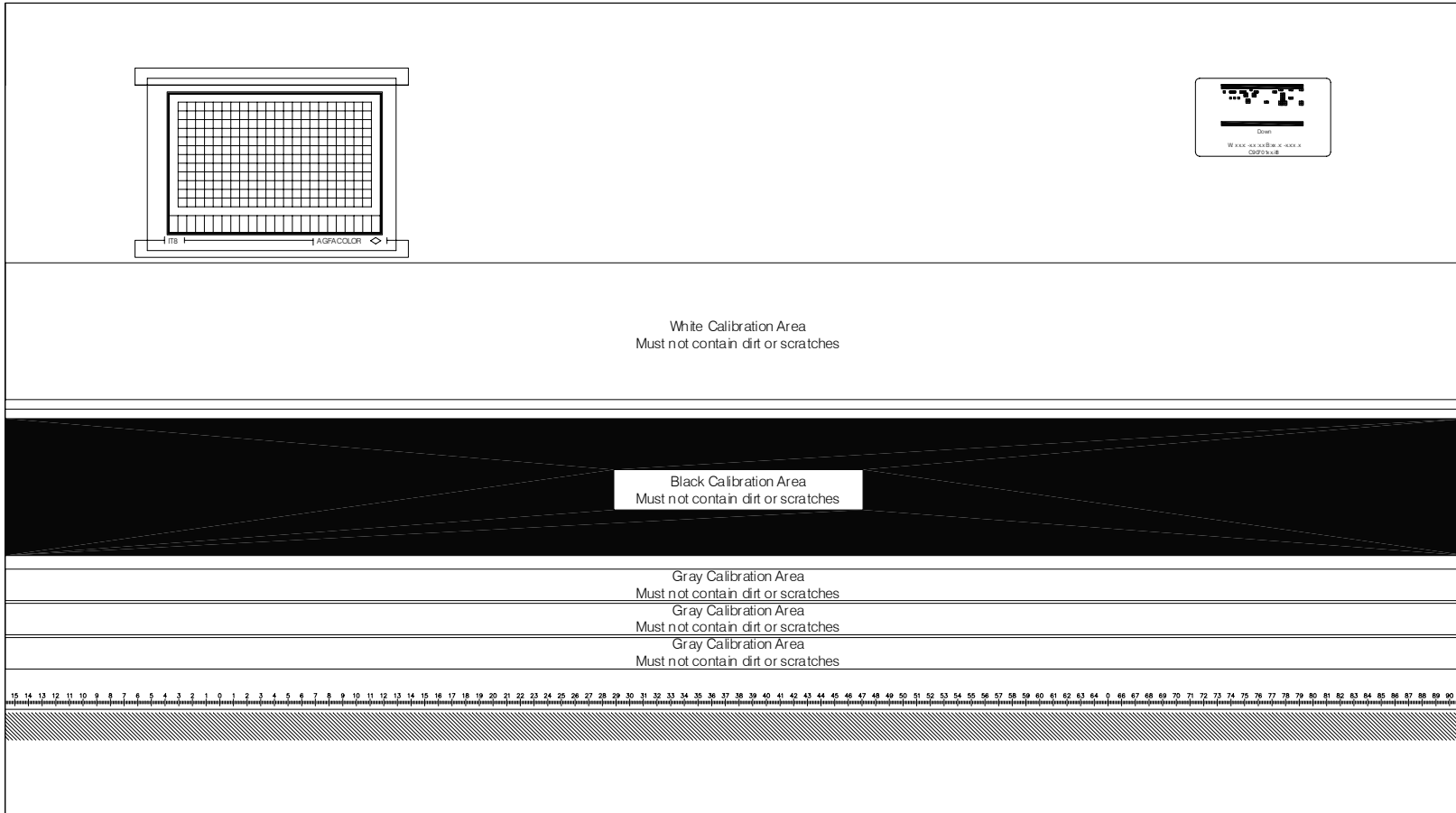

IT8-Sheet and patterns faces outwards when folded

Fig. 6-2 SM Calibration Sheet, 40"

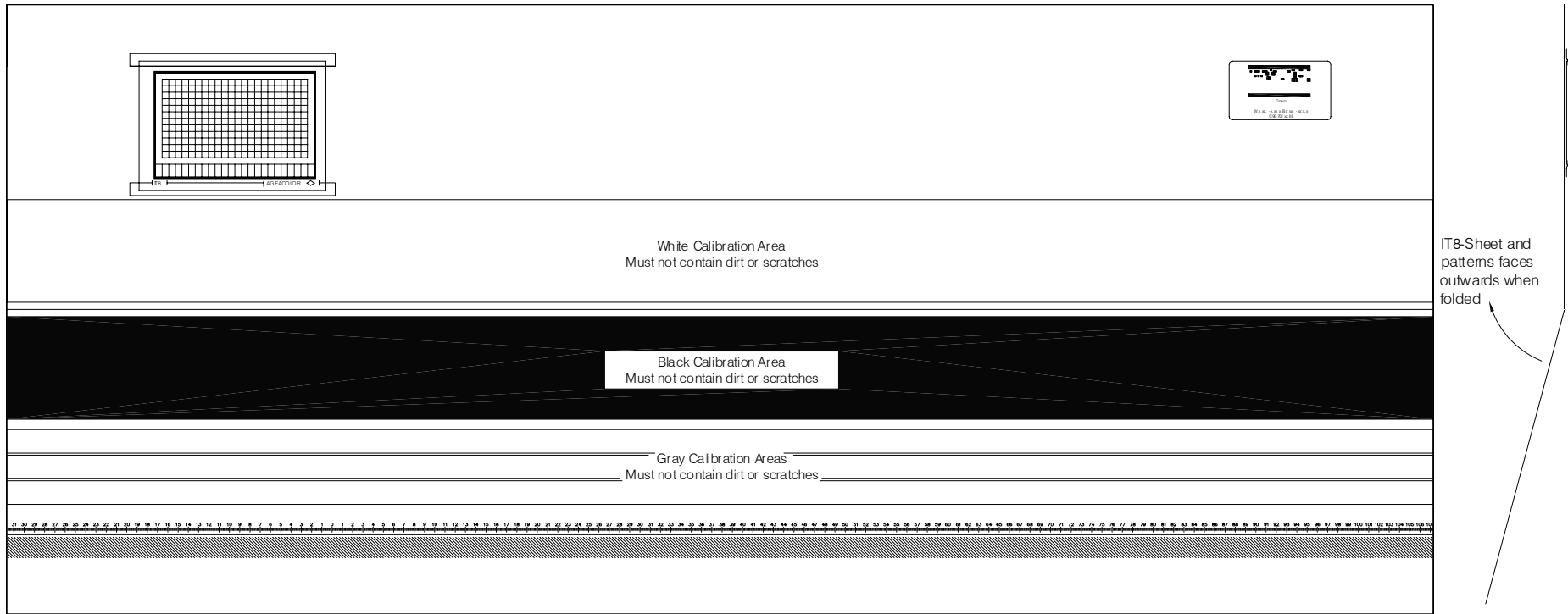

Fig. 6-3 SM Calibration Sheet, 54"

7. Troubleshooting

If contacting Contex for support always supply the following information:

Scanner Model
 Serial Number
 Firmware revision
 Description of the problem
 ScanDump of Light Profiles

7.1 Power-On Self-Test

The following operations are executed when the scanner is switched ON:

Operation	Description	Error Code
Check Scanner ID	Checks if the setting of the DIP switch on the Operator Panel is valid. Check if Smart Card is valid for the scanner type. All Indicators are ON.	Error 8
Hardware Self-Test	Checks SUC-, IMB/IMD-, and CBE/CBF-Boards. All Indicators are ON	Error 40 Error 50 Error 60
Start stepper motor to position Original	Tries to position the Original if one of the Original Sensors is activated and not in Extended Thickness mode. If Entry and Exit sensors both are activated or the Original Guide Plate is in Extended Thickness mode paper is not moved. Power and Wait Indicators are ON.	
Warm Up	Normally the Warm-Up time is app. 3 minutes. The Warm-Up time can be skipped by pressing the Forward and Reverse keys simultaneously. Power and Wait Indicators are ON.	
Light Profile Correction	The Light Profile is Corrected at power-on, Power and Wait Indicators are ON. Thereafter the Light Profile is Corrected whenever the scanner is idle and the Original Guide Plate is down in Normal position. If a required Light Profile Correction is suspended (Extended Thickness) the Wait Indicator blinks.	Error 30
Stitching	The scanner is Stitched at power-on and thereafter whenever the scanner is idle and the Original Guide Plate is down in Normal position. Power and Wait Indicators are ON. If a required Light Profile Correction is suspended (Extended Thickness) the Wait Indicator blinks.	Error 32

7.2 LED Indicators on Operator Panel

Power LED (Green and Red)	
Booting and Power-On-Self-Test:	Yellow (Green & Red ON)
Warm Up	Green
Power ON (Operating mode)	Green
Low Power mode (Sleep mode)	Red
Scanner in Test mode (SCANtest 6)	OFF

Diagnostic LED (Red)	
Booting and Power-On-Self-Test:	Red
Warm Up	OFF
Normal Operation	OFF
Scanner in Test mode (SCANtest 6)	Red
Error Condition, see Section 7.3.1 below.	Blinking

Wait LED (Yellow)	Media Thickness Setting	
	Normal	Extended Thickness
Booting and Power-On-Self-Test:	Yellow	Yellow
Warm Up	Yellow	Yellow
Normal Operation:	OFF	OFF
Automatic update of Light Profile Correction has been suspended for a period exceeding the built-in update-timer or the scanner has been switched ON with the Original Guide Plate set for Extended Thickness.	Blinking Hint: May also occur during intensive scanning in batch mode or if original Exit and Entry Sensors are both activated during power on.	Blinking Hint: Lower Original Guide Plate to Normal position to allow Light Profile Correction to be done.
Error Condition, Diagnostic is blinking, see Section 7.3.1 below.	Blinking	Blinking

Ready LED (Green and Red)	Media Thickness Setting	
	Normal	Extended Thickness
Booting and Power-On-Self-Test:	Yellow (Red & Green ON)	Yellow (Red & Green ON)
Warm Up	OFF	OFF
No media	OFF	Red
Media inserted	Green	Yellow (Red & Green ON)
Scanning	Blinking Green / OFF	Blinking Yellow / Red
ATAC mode (MAGNUM XL 54 only)	Blinking Yellow / OFF	Blinking Yellow / OFF
Error Condition: Diagnostic LED is blinking, see Section 7.3.1 below.	Blinking Green / OFF	Blinking Green / OFF or Yellow/Red

7.3 Error Codes

7.3.1 Error Codes displayed on the Operator Panel

A blinking Diagnostic Indicator indicates an error condition. The error may be identified by an Error Code Number being displayed on the screen and/or by the following combinations of blinking (F) indicators on the Operator Panel:

Diagnostic	Wait	Ready	Error Description
F	1 x F	OFF	Correction of Camera A failed
F	2 x F	OFF	Correction of Camera B failed
F	3 x F	OFF	Correction of Camera C failed
F	4 x F	OFF	Correction of Camera D failed
F	OFF	1 x F	Error on SUC-Board
F	OFF	2 x F	Error on CBE/CBF-Board
F	OFF	3 x F	Invalid Scanner ID setting
F	OFF	4 x F	Error on IMB/IMD-Board
F	OFF	5 x F	Invalid Smart Card
F	F	F	Scanner is in Boot Mode
F	OFF	OFF	Refer to the Section below

1 x F, 2 x F, ... means that the Wait and/or the Ready Indicator blinks 1, 2, ... times every time the Diagnostic Indicator is turned ON.

F, F, F means that all three indicators are blinking simultaneously.

7.3.2 Error Codes displayed on the PC Screen

If SCANtest 6 is started when the scanner is in Error condition it will display the Error Code Number and a short description of the error.

The following error messages may be displayed:

Error Code and Description	Refer to page:
ERROR 08-147: Invalid Scanner ID Switch setting	152
ERROR 08-149: Invalid Smart Card for this scanner type	
ERROR 08-208: Keyboard check failed	
ERROR 08-220: Lamp Cartridge detached	
ERROR 10-159: Paper Jam	
ERROR 30-140: Correction of Camera A failed	152
ERROR 30-141: Correction of Camera B failed	
ERROR 30-142: Correction of Camera C failed	
ERROR 30-143: Correction of Camera D failed	
ERROR 30-240: Correction of Camera A failed	
ERROR 30-241: Correction of Camera B failed	
ERROR 30-242: Correction of Camera C failed	
ERROR 30-243: Correction of Camera D failed	
ERROR 32-144: Stitching of Camera A/B failed	153
ERROR 32-145: Stitching of Camera B/C failed	
ERROR 32-146: Stitching of Camera C/D failed	
ERROR 32-244: Stitching of Camera A/B failed	
ERROR 32-245: Stitching of Camera B/C failed	
ERROR 32-246: Stitching of Camera C/D failed	
ERROR 40-35: CBx, Camera A not found	154
ERROR 40-36: CBx, Camera B not found	
ERROR 40-37: CBx, Camera C not found	
ERROR 40-38: CBx, Camera D not found	

Error Code and Description	Refer to page:
ERROR 40-39: CBx, Camera A AMP RAM error	
ERROR 40-40: CBx, Camera B AMP RAM error	
ERROR 40-41: CBx, Camera C AMP RAM error	
ERROR 40-42: CBx, Camera D AMP RAM error	
ERROR 40-43: CBx, Camera A EVEN LINE RAM error	
ERROR 40-44: CBx, Camera B EVEN LINE RAM error	
ERROR 40-45: CBx, Camera C EVEN LINE RAM error	
ERROR 40-46: CBx, Camera D EVEN LINE RAM error	
ERROR 40-47: CBx, Camera A ODD LINE RAM error	
ERROR 40-48: CBx, Camera B ODD LINE RAM error	
ERROR 40-49: CBx, Camera C ODD LINE RAM error	
ERROR 40-50: CBx, Camera D ODD LINE RAM error	
ERROR 40-75: CBx, FPGA CB status error	
ERROR 40-76: CBx, FPGA CB done error	
ERROR 40-84: CBx, Camera cables misplaced	
ERROR 40-134: Unable to Basic Calibrate	
ERROR 40-135: Unable to calibrate analog offset	
ERROR 40-136: Unable to calibrate analog gain	
ERROR 40-137: Unable to Calibrate Pixel Offset	
ERROR 40-138: Timed-out on calibrating analog part	
ERROR 40-139: An IT8 white patch was 0	
ERROR 40-170: Camera A, Unable to calibrate analog offset	
ERROR 40-171: Camera B, Unable to calibrate analog offset	
ERROR 40-172: Camera C, Unable to calibrate analog offset	
ERROR 40-173: Camera D, Unable to calibrate analog offset	
ERROR 40-174: Camera A, Unable to calibrate analog gain	
ERROR 40-175: Camera B, Unable to calibrate analog gain	
ERROR 40-176: Camera C, Unable to calibrate analog gain	
ERROR 40-177: Camera D, Unable to calibrate analog gain	
ERROR 40-178: Camera A, Unable to calibrate pixel offset	
ERROR 40-179: Camera B, Unable to calibrate pixel offset	
ERROR 40-180: Camera C, Unable to calibrate pixel offset	
ERROR 40-181: Camera D, Unable to calibrate pixel offset	
ERROR 40-182: Camera A, Timed-out, calibrating analog part	
ERROR 40-183: Camera B, Timed-out, calibrating analog part	
ERROR 40-184: Camera C, Timed-out, calibrating analog part	
ERROR 40-185: Camera D, Timed-out, calibrating analog part	
ERROR 40-186: Camera A, Unable to calibrate ext. DAC	
ERROR 40-187: Camera B, Unable to calibrate ext. DAC	
ERROR 40-188: Camera C, Unable to calibrate ext. DAC	
ERROR 40-189: Camera D, Unable to calibrate ext. DAC	
ERROR 50-17: SUx, Register 1 error	154
ERROR 50-18: SUx, Register 2 error	
ERROR 50-19: SUx, Register 3 error	
ERROR 50-20: SUx, Register 6 error	
ERROR 50-21: SUx, Register 8 error	
ERROR 50-22: SUx, FPGA01 register error	
ERROR 50-23: SUx, FPGA03 register error	
ERROR 50-24: SUx, FPGA04 register error	

Error Code and Description	Refer to page:
ERROR 50-25: SUx, FPGA05 register error	
ERROR 50-26: SUx, FPGA06 register error	
ERROR 50-27: SUx, FPGA07 register error	
ERROR 50-28: SUx, FPGA08 register error	
ERROR 50-51: SUx, DB 0 reset error	154
ERROR 50-52: SUx, DB 0 count error	
ERROR 50-53: SUx, DB 0 data error	
ERROR 50-54: SUx, DB 1 reset error	
ERROR 50-55: SUx, DB 1 count error	
ERROR 50-56: SUx, DB 1 data error	
ERROR 50-57: SUx, CNTL RAM error	
ERROR 50-58: SUx, LIN RAM error	
ERROR 50-59: SUx, GAMMA RAM error	
ERROR 50-60: SUx, INDEX RAM error	
ERROR 50-61: SUx, LUT ATBS error	
ERROR 50-62: SUx, LUT A error	
ERROR 50-63: SUx, LUT B error	
ERROR 50-64: SUx, LUT C error	
ERROR 50-65: SUx, Color space converter data error	
ERROR 50-66: SUx, Color space converter coefficient error	
ERROR 50-67: SUx, Position counter reset error	
ERROR 50-68: SUx, Position counter count error	
ERROR 50-69: SUx, Data path error	
ERROR 50-70: SUx, Data path length error	
ERROR 50-71: SUx, FPGA 8k status error	
ERROR 50-72: SUx, FPGA 8k done error	
ERROR 50-73: SUx, FPGA 10k status error	
ERROR 50-74: SUx, FPGA 10k done error	
ERROR 50-77: SUx, FPGA 6k status error	
ERROR 50-78: SUx, FPGA 6k done error	
ERROR 50-79: SUx, FPGA 20k status error	
ERROR 50-80: SUx, FPGA 20k done error	
ERROR 50-81: SUx, FPGA03 function error	
ERROR 50-90: SUx, Sector in write able area of Flash is locked	154
ERROR 50-91: SUx, Parameter block erasure failed	
ERROR 50-92: SUx, Parameter block write failed	
ERROR 50-93: SUx, Profile block erasure failed	
ERROR 50-94: SUx, Profile block write failed	
ERROR 50-95: SUx, Flash block erasure failed	
ERROR 50-96: SUx, Flash block write failed	
ERROR 50-99: SUx, unknown Flash device type	
ERROR 50-100: pad task creation failed	154
ERROR 50-101: pcd task creation failed	
ERROR 50-102: pbl task creation failed	
ERROR 50-103: err task creation failed	
ERROR 50-104: pio task creation failed	
ERROR 50-105: pop task creation failed	
ERROR 50-106: psn task creation failed	
ERROR 50-107: psc task creation failed	
ERROR 50-108: psi task creation failed	
ERROR 50-109: psp task creation failed	

Error Code and Description	Refer to page:
ERROR 50-110: pts task creation failed	
ERROR 50-111: pto task creation failed	
ERROR 50-112: mbPad creation failed	
ERROR 50-113: mbPbl creation failed	
ERROR 50-114: mbPcd creation failed	
ERROR 50-115: mbPio creation failed	
ERROR 50-116: mbPsi creation failed	
ERROR 50-117: mbPsp creation failed	
ERROR 50-118: mbPts creation failed	
ERROR 50-119: mbPio pending	
ERROR 50-120: hmm out of memory	
ERROR 50-121: hmm un-allocated memory block	
ERROR 50-122: pop request failed, position unknown	
ERROR 50-123: pop request failed, invalid command	
ERROR 50-124: pio event	
ERROR 50-125: psi event	
ERROR 50-126: pcd event	
ERROR 50-127: psc event	
ERROR 50-128: psi message event	
ERROR 50-130: semPsp posted more than once	154
ERROR 50-131: psp received unknown mail	
ERROR 50-132: mrsErrorTbl missing entry	
ERROR 50-133: unknown reboot command	
ERROR 50-190: pbl received invalid mail	154
ERROR 50-191: mbPss creation failed	
ERROR 50-192: pss task creation failed	
ERROR 50-193: mbPss pending	
ERROR 50-194: pss event	
ERROR 50-195: stitch write failed	
ERROR 50-196: pmb validation failed	
ERROR 50-197: pointer out of range	
ERROR 50-198: unknown camera board	
ERROR 50-199: unknown SUx/CCD combination	
ERROR 50-200: invalid timeout task	
ERROR 50-201: invalid data length	
ERROR 50-202: semPsp already owned by this SCSI unit	
ERROR 50-203: semPsp not released	
ERROR 50-204: new failed, out of memory	
ERROR 50-206: Light profile flash space overrun	
ERROR 50-207: pkb task creation failed	
ERROR 50-209: ppw task creation failed	154
ERROR 50-210: mbPpw creation failed	
ERROR 50-211: pus task creation failed	
ERROR 50-212: mbPus creation failed	
ERROR 50-213: pus event	
ERROR 50-214: psp task delete failed	
ERROR 50-215: pfi task creation failed	
ERROR 50-216: mbPfi creation failed	
ERROR 50-217: pfi event	
ERROR 60-29: IMx, SCSI 0 reset error	154

Error Code and Description	Refer to page:
ERROR 60-30: IMx, SCSI 0 register error	
ERROR 60-31: IMx, SCSI 0 FIFO error	
ERROR 60-32: IMx, SCSI 1 reset error	
ERROR 60-33: IMx, SCSI 1 register error	
ERROR 60-34: IMx, SCSI 1 FIFO error	
ERROR 60-82: IMx, USB chip error	
ERROR 60-83: IMx, wrong board version installed	
ERROR 60-85: IMx, 1394 chip error	
ERROR 70-86: MDAx, Unable to communicate with board	154
ERROR 70-87: MDAx, Failure on ATAC movement	
ERROR 70-219: Fan error	
ERROR 70-221: LMx, Board error	

7.4 Troubleshooting Hints

The scanner does not power-up

- Check the power supply connections.
- Check that all cable connectors are properly inserted into their sockets.
- Check voltages on the SMPS.
- Check the supply voltages on the LME-, CBE/CBF-, IMB/IMD, and SUC-Boards.

Error 08-147, 'Invalid Scanner ID'

- Error 08-147 indicates that the DIP Switch (pos. 4, 5, 6, 7, and 8) on the Operator Panel is set to an undefined scanner type or inconsistency between the detected scanner hardware and the Scanner ID switch setting, see Section 3.10.4, page 54.
- Error 08-147 may also indicate a bad connection between the SUC-Board and the Operator Panel.

Error 08-149, Invalid Smart Card

- The Smart Card is not valid for this scanner type.
- Error 08-149 may also indicate a bad connection between the SUC-Board and the Smart Card Reader.

Error 08-208, Keyboard check failed

- Check cable to Operator Panel.
- Replace Operator Panel.

Error 30-140 to 30-143, Light Profile Correction Failed (Color Channels)

Error 30-240 to 30-243, Light Profile Correction Failed (B/W Channel)

Error 30 is displayed if more than 200 consecutive pixels or a total of 1500 pixels cannot be adjusted up to the required White-Signal Level.

- Error 30 is most often caused by dirt on the Glass Plate or the White Background Plate and the first step should be to make sure that these parts are clean.

Next, use SCANtest 6, Test 9, to check the Light Profiles, see Section 4.2.1, page 87.

If the Light Profile is distorted, the cause may be:

- Incorrect Vertical Positioning, see Section 4.2.7, page 110.
- Incorrect Vertical Alignment (does not apply to 1-Camera scanners), run SCANtest 6, Test 11 or Scanner Maintenance.
- Lamp does not turn ON.
- Corrupted Basic Calibration.
Try to Erase Parameter Blocks, see Section 3.2.1, page 26. Remember to run Scanner Maintenance after Erase Parameter Blocks.
- Defective CBE/CBF-Board.

It is possible to override Error 30 from WIDEimage and go through with the scanning. Whether the result will be useful or not depends on the actual cause of Error 30.

Error 32-144 to 30-146, Stitching Failed (Color (Green) Channel)

Error 32-244 to 30-246, Stitching Failed (B/W Channel)

It has not been possible for the processor to detect one and only one image of the Stitching Wire in the scanned input.

- Make sure that the Glass Plate and the White Background Plate are clean. Dirt on the Glass Plate or the White Background Plate in the areas opposite the Stitching Wire may be interpreted as multiple images of the Stitching Wire and cause Error 32.
- Check the images of the Stitching wire using SCANtest 6, Test 9, see Stitching Images in Section 5.2, page 133.
 - White dust on the Stitching Wire may cause the image of the Stitching Wire to be too “short” to be detected.
 - One of the CCD-Cameras is so much out of focus that the image of the Stitching Wire does not reach down below the Stitching Threshold level, which is approximately 50% of the Corrected White-Signal level (incorrect Camera Adjustment).
 - The Stitching Wire may be broken.
- The CCD-Centering of one of the CCD-Cameras may be so much out of adjustment, that the image of the Stitching Wire falls outside the range where it can be detected by the scanner (incorrect Camera Adjustment).
 - Check CCD-Centering with SCANtest 6, Test 9, see images in Section 4.2.6, page 109.
- Erase Parameter Blocks, 3.2.1, page 26.
 - Run Scanner Maintenance.
- Replace SUC-Board.

Error 40-35 to 40-50 and 40-75, 40-76, 40-84, CBE/CBF-Board Errors

- Check that the Lamp is lit.
- Run SCANtest 6, Test 7 to verify the error.
- Check that all cable connectors are properly seated into their sockets.
- Check that no cables have been interchanged.
- Check the supply voltages on the boards.
- Replace CBE/CBF-Board.

Error 40-134 to 40-139, 40-170 to 40-189, CBE/CBF-Board Errors

- Run SCANtest 6, Test 7 to verify the error.
- Check that all cable connectors are properly seated into their sockets.
- Check the supply voltages on the boards.
- Check Light Profiles with SCANtest 6, Test 9, see Section 4.2.1, page 87.
- Erase Parameter Blocks, see Section 3.2.1, page 26.
- Run Scanner Maintenance.
- Replace Lamp.
- Replace CBE/CBF-Board.

Error 50-17 to 50-28, 50-51 to 50-81 and 50-90 to 50-99, SUC-Board Errors

- Run SCANtest 6, Test 7 to verify the error.
- Check that all cable connectors are properly seated into their sockets.
- Check the supply voltages on the board.
- Replace SUC-Board.
- Run Scanner Maintenance.

Error 50-100 to 50-217, Firmware related errors

- Upgrade firmware.
- Erase Parameter Blocks, see Section 3.2.1, page 26.
- Run Scanner Maintenance.

Error 60-29 to 60-34, 60-82 to 60-85, IMB/IMD-Board Errors

- Run SCANtest 6, Test 7 to verify the error.
- Check the supply voltages on the IMB/IMD-Board.
- Replace IMB/IMD-Board.

Error 70-86, 70-87, MDA-Board Errors

- Run SCANtest 6, Test 7 to verify the error.
- Check the supply voltages on the MDA-Board.
- Check ATAC Position Sensors.
- Replace IMB/IMD-Board.

Original Feed Problems

If the Stepper Motor does not run:

- Check supply voltage on the SMPS and LME-Board, Section 3.3, page 27 and Section 3.4, page 30.
- Replace LME-Board.
- Remove the Stepper Motor cable connector from J12 on the LME-Board and check the resistance of the two windings of the Stepper Motor:
 - Winding 1: Blue – Brown (Green)
 - Winding 2: Yellow - RedThe resistance should be approximately 3.7 ohms.
- Replace Motor.

If the Stepper Motor is overloaded (high noise level, original feed problems):

- Check supply voltage and the Stepper Motor Reference Voltages on the LME-Board, Section 3.4, page 30.
- Replace LME-Board.

Streaking (Vertical Lines)

Vertical Lines running from top to bottom of the scanned image are often caused by dust or dirt on the Glass Plate.

A description of how to locate the cause of vertical lines in the scanned image is given in:

Section 10.1.12, Test 20, Noise Test, page 174.

If it has been necessary to remove a CBE/CBF-Board for replacement or for cleaning of the CCD-chip, refer to Chapter 4, page 79 for adjustment instructions.

8. Disassembly and Assembly

Refer to the following figures:

Fig. 9-2 Transmission, page 168.

Fig. 9-3 Drive-Belt Tightener, page 169.

Fig. 9-4 Scanner Cross Section, page 170.

CAUTION:

Before removing any covers, turn the power switch OFF and disconnect the power cord.

The following Sections describe disassembly. For assembly, use the same procedures in reverse order.

8.1 Top Cover with Front Profile

Remove the two (three on 54" scanners) fixing screws along the lower edge of the Front Profile.

Pull the Front Profile away from the scanner to get the upper edge of the Top Cover off the heads of the guide screws.

Now, the Top Cover with Front Profile may be lifted off.

After replacement:

On 2-, 3-, and 4-camera scanners: Run SCANtest 6, Test 11 (Vertical Alignment and Stitching) or Scanner Maintenance.

8.2 End Covers

Remove the Top Cover.

Remove the Original Guide Plate, on 54" scanners: open Original guide Plate.

Remove the two M4 fixing screws under the Top Cover, one M4 fixing screw under the Original Guide Plate, and four M3 fixing screws along the lower edge of the End Covers.

On the right End Cover, two of the M3 screws are placed 50 mm above the lower edge, these screws must be M3x6 mm. If they are longer, they may touch the Mirror Chassis and disturb the camera adjustment when tightened.

8.3 Rear Cover

Remove the four (five on 54" scanners) fixing screws along the centerline of the Rear Cover and the three (25" scanners) or four (36" and 40" scanners) or five (54" scanners) fixing screws along the lower edge of the Rear Cover.

The Rear Cover may now be detached.

8.4 Bottom Plate

Remove the End Covers.

Remove the Rear Cover.

Remove the two fixing screws, one on the left and one on the right side plate.
Do not grip on the Mirror Chassis when lifting the scanner for removal of the Bottom Plate.

8.5 Top Profile (Lid)

On scanners with ATAC:

Remove the Streamer and the four fixing screws located behind the Streamer.

Open the Top Cover (Lid)

On all scanner models:

Release the lock screw in one of the bearings of the Top Profile.

Slide the bearing off and lift off the Top Profile

8.6 Original Guide Plate with ATAC

Move Original Guide Plate to upper position.

Open Original Guide Plate.

Remove Streamer and the four fixing screws located behind the Streamer.

Open the Top Cover.

Disconnect cable from MDAB-Board.

Pull the cable off the Original Guide Plate.

Remove the two fixing screws for the hinge bushings.

Lift off the Original Guide Plate.

8.7 Glass Plate

On 25", 36" and 40" scanners:

The Glass Plate is hinged on two small brass bearings, one on each side plate.

Remove the mounting screws for the two bearings and lift off the Glass Plate.

When replacing the Glass Plate, the bearing should be mounted with the flange against the side plate.

On scanners with ATAC:

Move Original Guide Plate to upper position.

Open Original Guide Plate.

Open the Glass Plate and lift it off its hinges.

8.8 Entry Roller Shield

Remove the Top Cover.

Remove the Original Guide Plate.

Remove the two front most guide pins for the Original Guide Plate (25", 36" and 40" scanners).

Remove the Glass Plate (be careful not to loose the two bearings when lifting off the Glass Plate in 25", 36" and 40" scanners).

Loosen (do not remove) the twelve (25" scanners) or sixteen (36" and 40" scanners) or 24 (54" scanner) screws (half are Allen screws and half are screws with 6 mm hexagonal head) on the front side of the Entry Roller Shield.

Caution: 36", 40", and 50" scanners only: Do not loosen the two fixing screws for the center bearing of the Feed Roller (5.5 mm hexagonal heads or Allen screws secured by seal lacquer).

Gently remove the Entry Roller Shield (be careful not to bend or in any other way damage the shield).

When replacing the Entry Roller Shield, the Glass Plate must be mounted and closed down before tightening the fixing screws of the Entry Roller Shield. While tightening the screws, gently press the Entry Roller Shield downwards so that the rear edge of the Entry Roller Shield is in contact with the edge of the Glass Plate. This is to prevent the original from being caught by the edge of the Entry Roller Shields when it is moving backwards.

8.9 Exit Roller Shield

For 25", 36" and 40" scanners

Remove the Top Profile (Lid).

Remove the Original Guide Plate.

Remove the two rear guide pins for the Original Guide Plate.

Remove the left and right hinges for the Top Profile (Lid).

For 54" scanner

Remove Original Guide Plate.

Remove the Rear Cover.

Loosen (do not remove) the twelve (25" scanners) or sixteen (36" and 40" scanners) or 24 (54" scanner) screws (half are Allen screws and half are screws with 6 mm hexagonal head) on the front side of the Entry Roller Shield.

Caution: 36", 40", and 54" scanners only: Do not loosen the two fixing screws for the center bearing of the Feed Roller (5.5 mm hexagonal heads or Allen screws secured by seal lacquer).

Gently remove the Entry Roller Shield (be careful not to bend or in any other way damage the shield).

When replacing, gently press the Exit Roller Shield downwards while tightening the fixing screws.

8.10 Mirror Chassis

Remove all Covers.

Turn scanner upside down.

Remove the brackets with the two rear rubber feet.

Remove the four 4 mm nuts and washers (on the outside of the side plates) that hold the Mirror Chassis.

Pull out the four tight-fitting bolts (two at each end).

The Mirror Chassis is now free to be lifted out.

To replace the Mirror Chassis, reverse the order of removal.
Always clean the mirrors before replacing the Mirror Chassis.

After replacement of the Mirror Chassis and Covers:

Check Camera Adjustment, Chapter 4.2, page 86, *especially Vertical Positioning, Section 4.2.7, page 110.*

Run Scanner Maintenance.

8.11 Reflector Assembly

Remove all Covers.

Remove Glass Plate.

This is to prevent scratching of the Glass Plate when removing and replacing the Reflector Assembly.

Remove the Fluorescent Lamp.

Turn the scanner upside down *Do not grip on the Mirror Chassis.*

Remove the Mirror Chassis.

Disconnect the cable from the OSB-Board.

Push the plug down through the cutout in the Reflector Assembly. The cable is now free to be pulled out through the opening in the side plate.

To re-install the cable grip the plug with flat-nose pliers and - through the opening in the side plate - push the plug up through the cutout in the Reflector Assembly.

Remove the 12 screws that hold the Reflector Assembly.

Lift out the Reflector Assembly.

To prevent damage to the Stitching Wire when replacing the Reflector Assembly, the notches in the Reflector Assembly should be aligned with the Stitching Wire. This may be done by carefully keeping the holes for the fixing screws aligned with the holes in the scanner chassis.

9. Replacement of Parts

Refer to the following figures:

Fig. 9-2 Transmission, page 168.

Fig. 9-3 Drive-Belt Tightener, page 169.

Fig. 9-4 Scanner Cross Section, page 170.

CAUTION:

Before removing any covers, turn the power switch OFF and disconnect the power cord.

The following Sections describe removal of parts. For replacement, use the same procedures in reverse order.

9.1 Feed Roller Shaft

Remove the Entry respectively Exit Roller Shield.

Remove the Guard Plate over the OIB-Board with bracket.

Remove the OIB-Board.

The Sensor Actuators are now turned into an upright position allowing the Feed Roller Shaft to be lifted out.

Remove the Thickness Detector at the Drive Belt end of the Entry Roller.

Remove the Drive Belt from the pulley.

When replacing, check and if necessary adjust the Drive Belt tension, see Fig. 9-3, page 169.

Loosen the two lock screws and pull off the pulley, be careful not to lose the joint tongue in the shaft.

A dismantling screw may be useful for pulling off the pulley.

Remove the two screws, which hold the bearing at the pulley end.

Pull off the bearing and washers; note the number of washers for later replacement.

Remove the top part of the center bearing (36", 40" and 54" scanners only).

The top parts of the center bearings of the Entry and Exit Roller Shafts must not be interchanged, therefore please mark the top part before removal.

Remove the two screws, which hold the bearing at the Operator Panel end.

Pull off the bearing and washers; note the number of washers for later replacement.

Slide the shaft towards the pulley end to let it go free of the side plate.

Lift out the Feed Roller Shaft.

When removing the shaft, note the number and position of washers on the ends of the shaft for later replacement.

After replacement, readjust the Original Sensors, see Section 3.14, page 66 and check Media Thickness Detector, see Section 3.17, page 78.

9.2 Original Sensor Actuators

Remove the Feed Roller Shaft.

Remove the Torsion Spring from the actuator.

Remove the Thickness Detector at the Operator Panel end.

Loosen (do not remove) the screws holding the bearings of the actuator just enough to allow the Original Sensor Actuator to be lifted out of the bearing.

Remove the Original Sensor Actuator.

After replacement, readjust the Original Sensors, see Section 3.14, page 66 and check Media Thickness Detectors, see Section 3.17, page 78.

9.3 Stitching Wire

Remove the Reflector Assembly.

Remove the fixing screws, clamps, and leaf springs for the Stitching Wire and remove the defective wire.

When replacing the Stitching Wire, make sure that it is placed in the notches of the leaf springs.

The Stitching Wire should be tightened to give a deflection of 2 – 2.5 mm on each of the two leaf springs, see Fig. 5-2, page 132.

9.4 Fluorescent Lamp

CAUTION:

Turn the power switch OFF and disconnect the power plug.

Remove the Top Cover.

Remove the Original Guide Plate.

Remove the End Cover at the Power Inlet end.

Remove the fixing screw under the Lamp Holder.

Pull off the Lamp Holder.

The Fluorescent Lamp may now be pulled out.

Be careful not to touch the Stitching Wire, if any, when removing and replacing the lamp.

Place the new Fluorescent Lamp (be careful not to touch the Stitching Wire if any) and make sure that it is inserted properly in the lamp holder at the keyboard end. Then proceed in reverse order of removal.

Make sure, that the cable for the Lamp Sensor does not get caught when replacing the Lamp Holder.

After replacement:

Check and if necessary adjust the Lamp Driver, Section 3.4.2, page 30.

Replace all covers.

Reset “Lamp On Time”, see Section 10.1.1, page 172.

Run Scanner Maintenance.

9.5 Stepper Motor

See Fig. 9-2, page 168.

Remove the Original Guide Plate.

Remove the Top Cover.

Remove the End Cover at the Power Inlet end.

Remove the Drive Belt from the pulley.

When replacing, check and if necessary adjust the Drive Belt to 1.5 kg (15 N), see Fig. 9-3, page 169.

Remove the four large fixing screws holding the mounting plate for the stepper motor.

On 1-Camera scanners the SMPS must be moved to give room for pulling out the stepper motor. Remove the two fixing screws for the SMPS mounting console to allow the SMPS to be moved.

The Stepper Motor with mounting plate is now free to be removed.

9.6 Camera Motor

See Fig. 4-44, page 121.

Remove the Original Guide Plate.

Remove the Top Cover.

Disconnect the motor from the connector on the CBE/CBF-Board.

Remove the two Motor Bracket fixing screws.

When replacing: Make sure that the cylinder shaped nut on the spindle rests correctly in the cutout of the Vertical Alignment Arm. The Motor Bracket should be pushed to the uppermost position when tightening the fixing screws to ensure sufficient tension of the drive belt.

The Camera Motor (Bracket) is now free to be removed.

Run SCANtest 6, Test 11 or Scanner Maintenance (Vertical Alignment).

9.7 Camera Board, CBE/CBF

Note: The Camera Board includes Mounting Plate and CCD, these parts should never be disassembled, see Fig. 4-3, page 84.

Remove the Original Guide Plate.

Remove the Top Cover.

Disconnect ribbon cable from the CBE/CBF-Board.

Remove the Camera Motor.

Remove the four fixing nuts for the CCD Mounting Plate, see Fig. 4-3, page 84.

The Camera Board (with Mounting Plate) is now free to be removed.

After replacement of CBE/CBF-Board, do:

- CCD-Centering, Section 4.2.6, page 109.
- Vertical Positioning, Section 4.2.7, page 110.
- Check Scan-Width, if it is within the limits given in Section 4.2.5, page 99, Focus will also be OK, and no further adjustments are required.
- Run Scanner Maintenance, Section 6.1.7, page 142.

These adjustments can be made without loosening the Camera Fixing Screws and without loosening the Focus Lock Ring / Lock Screw.

9.8 Lamp Sensor Board, OSB

Remove all Covers.

Remove the Mirror Chassis.

There is now free access to the Lamp Sensor Board.

After replacement:

Readjust the Lamp Driver, Section 3.4.2, page 30.

Check Camera Adjustment, Chapter 4.2, page 86, *especially Vertical Positioning, Section 4.2.7, page 110.*

Run Scanner Maintenance.

9.9 Interface Boards, IMB and IMD

Remove Top Cover.

Remove Right End Cover.

Remove end cover of Interface Board Compartment (19 screws).

Disconnect SCSI Connector (IMBA and IMDA only).

Remove the EMC Contact Spring that connects the USB, respectively the IEEE 1394, connector housing to Interface Compartment.

Remove the 3 fixing screws that secure the Interface Board.

The Interface Board is now free to be pulled out.

Important: To maintain the EMC properties of the scanner, the EMC Contact Spring must be mounted after replacement of the Interface Board.

9.10 Dust Filter on Fan

Remove Top Cover.

Remove (un-snap) retainer with dust filter.

Replace dust filter media.

Snap retainer and filter back on to the fan.

9.11 White Background Plate

On 54" scanner with ATAC

Open Original Guide Plate.

Remove the stop plate (2 screws) at the left end of the Original Guide Plate.

Pull out the White Background Plate.

All other models:

Remove the Original Guide Plate from the scanner.

Place the Original Guide Plate with the front down.

Remove the two fixing screws for the Stop Bracket at one end of the Original Guide Plate.

Lift out the Stop Bracket.

Pull out the White Background Plate.

After replacement:

Run Scanner Maintenance.

9.12 Slider for Media Thickness Adjustment

Does not apply to scanners with ATAC

Remove the Original Guide Plate from the scanner.

Place the Original Guide Plate with the front down.

Remove the two fixing screws and guide bushings for the Adjustment Slider.

The Adjustment Slider may now be removed.

9.13 Elevation Motor (ATAC)

Open Top Cover (Lid) of Original Guide Plate.

Remove the two (M3) fixing screws for the motor bracket.

Pull the motor with bracket off.

Move motor bracket and the flexible coupling to the new motor.

Re-install the motor and adjust the flexible coupling to a play of 1 mm, see Fig. Fig. 3-26, page 74.

Secure the motor cable with cable ties.

9.14 Original Guide Sensors (ATAC)

See Fig. 3-24, page 72 and Fig. 3-25, page 73

Open Top Cover (Lid) of Original Guide Plate.

Remove the fixing screws for the sensor bracket.

Click the sensor off the bracket and replace.

Install the sensor and adjust as described in Section 3.15, page 69

9.15 Gas Spring for Guide Plate

When replacing the Gas Spring which helps to keep the Guide Plate open, use a screw driver or the like to support the mounting bracket and to swing it into position when removing and placing the fixing screws, see Fig. 9-1 below.

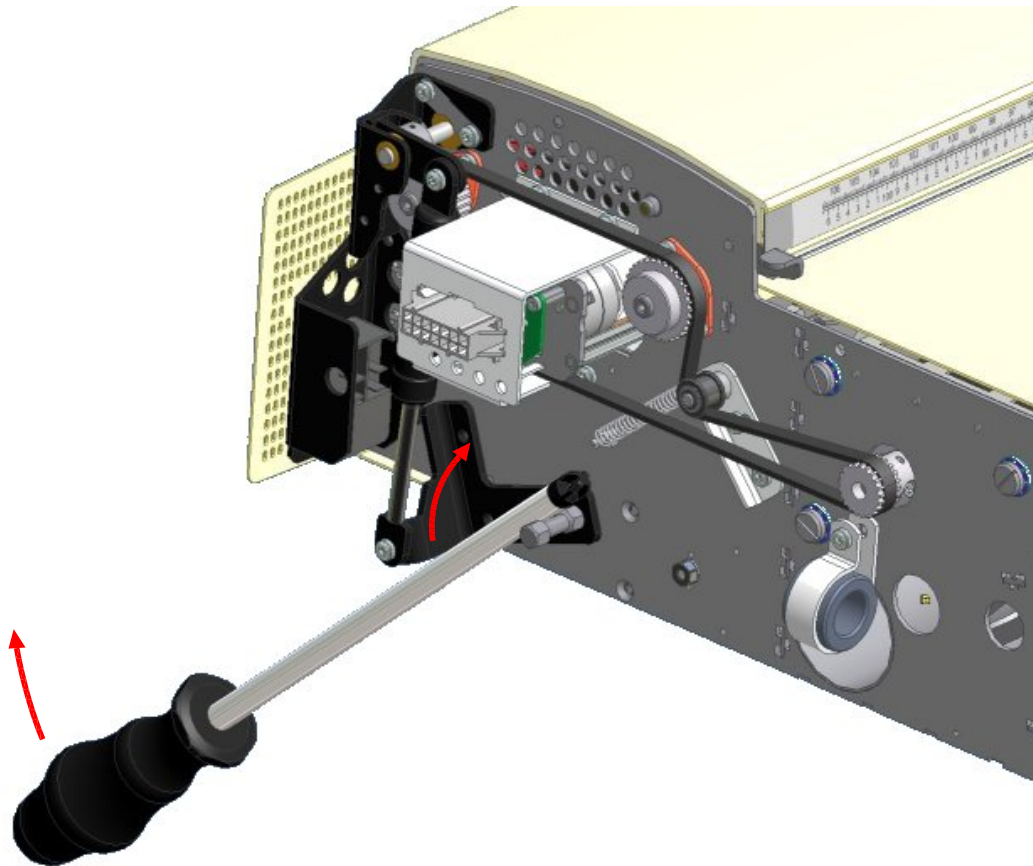

Fig. 9-1 Gas Sprin for Guide Plate

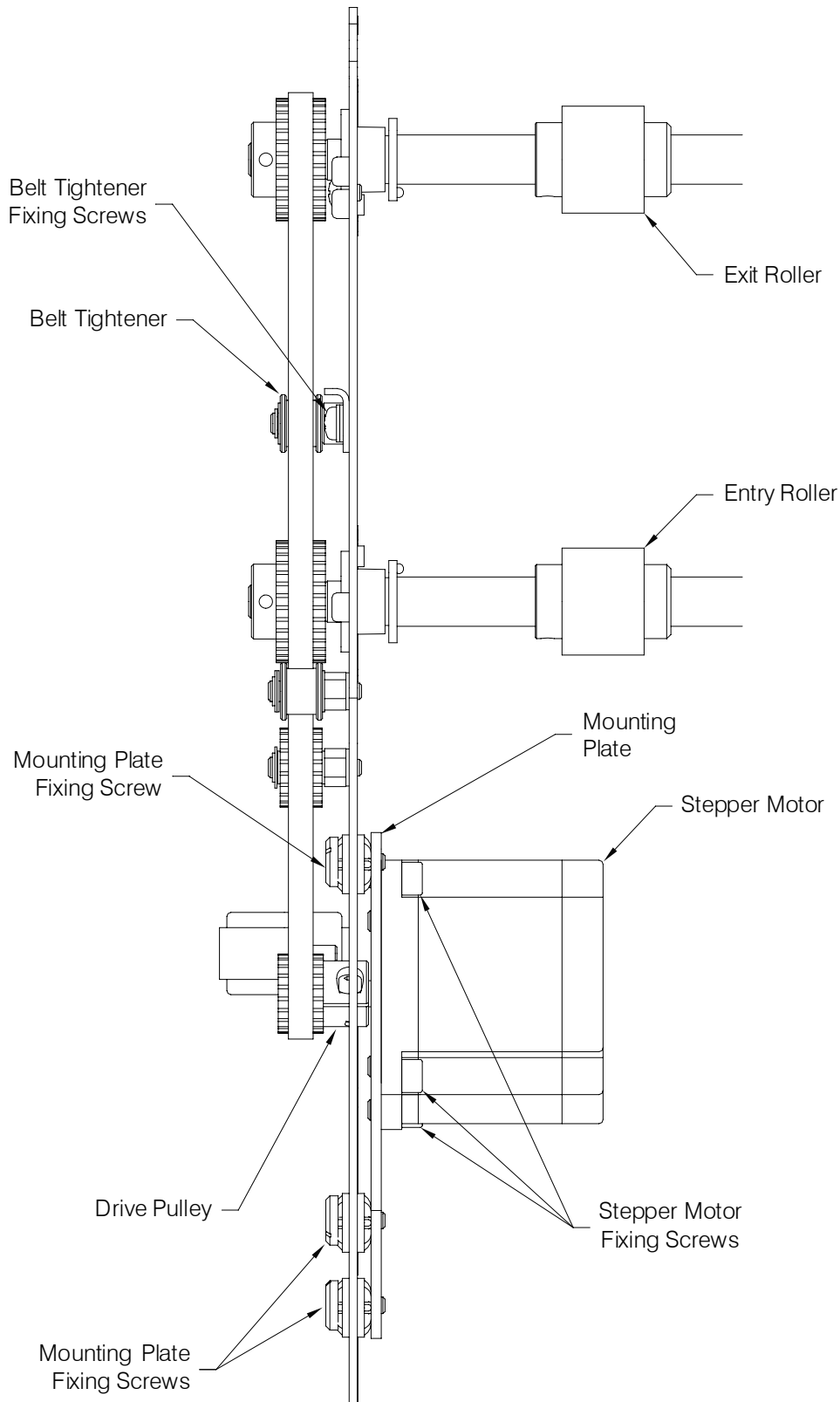

Fig. 9-2 Transmission

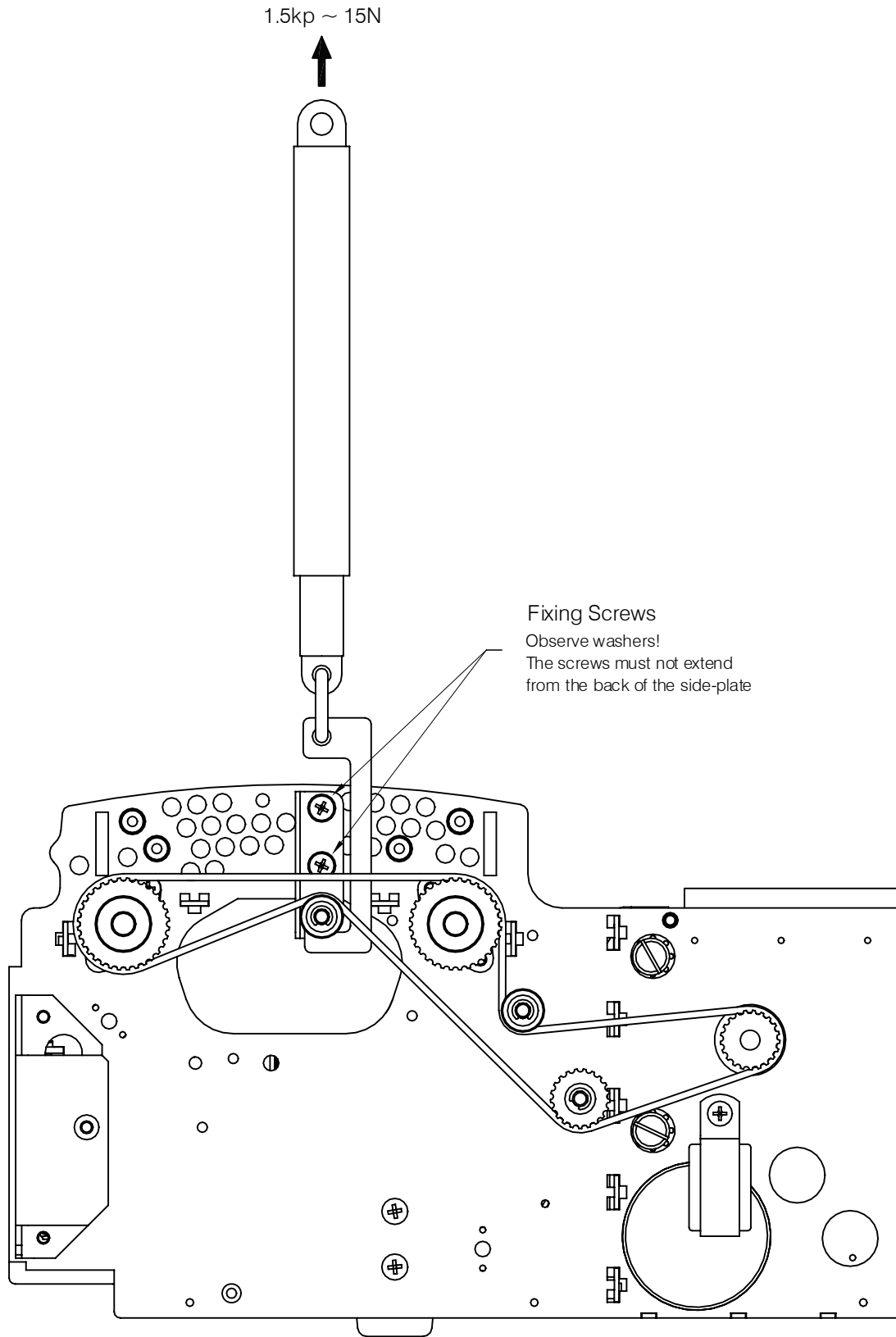

Fig. 9-3 Drive-Belt Tightener

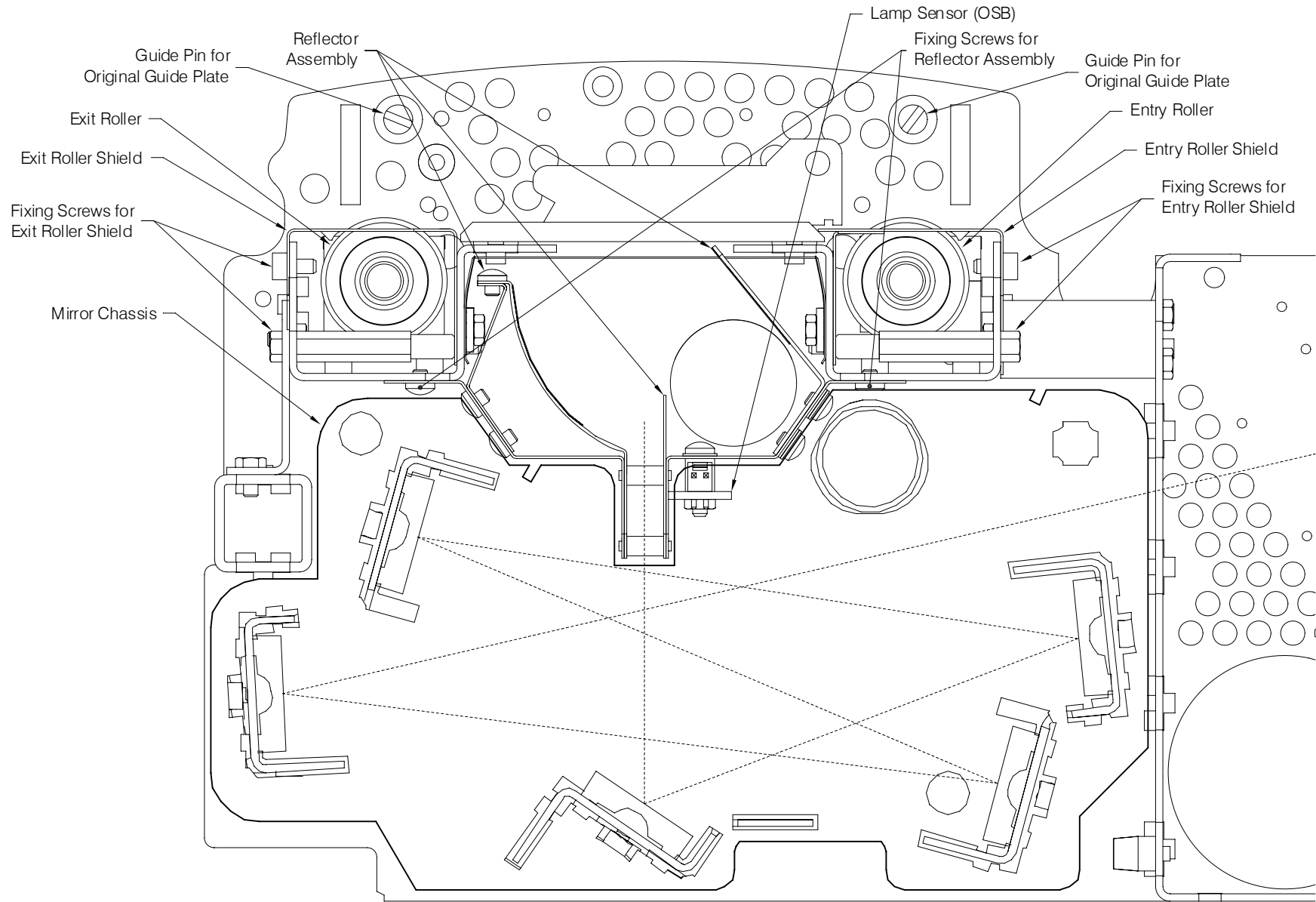

Fig. 9-4 Scanner Cross Section

10. SCANtest 6

The purpose of the scanner test program, SCANtest 6, is to support troubleshooting and adjustment of Contex Wide Format Scanners.

SCANtest 6 for Win98/2000/Me/NT4.0 is available from the Contex web-site:

www.contex.com

When SCANtest 6 has been started, the scanner is switched into Test Mode, and the Diagnostic LED Indicator on the Operator Panel is turned ON.

Scanner Test Program Menu

Test 1:	Scanner Information
Test 2:	LED Test
Test 3:	Key Test
Test 4:	Original-Sensor Test
Test 5:	Lamp Test
Test 6:	Motor Test
Test 7:	Complete Hardware Test
Test 9:	Camera Adjustment
Test 11:	Stitching and Vertical Alignment
Test 12:	Adjust Y-Axis Scaling
Test 13:	Switch Scanner to Test Mode
Test 20:	Noise Test
Test 21:	Scan Dump
Test 27:	Camera Adjustment Wizard
Test 28:	Original Guide Sensor Test
Test 30:	Calibrate ATAC

If SCANtest 6 is started when the scanner is in Error Mode, the Error Code Number and a short description of the error will be displayed on the screen.

10.1 Description of SCANtest 6

10.1.1 Test 1, Scanner Information

Purpose: To display scanner data and to enter or change the serial number of the scanner. The serial number is stored in Flash memory on the SUC-Board.

The following is displayed:

Scanner Model:
 Firmware Release:
 Firmware Release Date:
 Firmware Build:
 FPGA Revision:
 FPGA Release Date:
 Boot Code Revision:
 Boot Code Release Date:
 Scanner ID Switch:
 SCSI ID:
 Serial Number:
 Lamp Light On: *)

*) Password for reset of counter is “xetnoc”

10.1.2 Test 2, LED Test

Purpose: To test the LED Indicators on the Operator Panel.

Description:

All LEDs are sequentially switched ON/OFF until Test 2 is terminated.

10.1.3 Test 3, Key Test

Purpose: To test the Keys on the Operator Panel.

Description

Each key on the Operator Panel will turn a LED ON when pressed.

Key	LED
Forward and Reverse	Ready (Green)
Appl. (E-mail, Scan, and Copy)	Wait
Power	Wait
ATAC key	Ready (Green)

10.1.4 Test 4, Original-Sensor Test

Purpose: To test the Original Sensors and the Media Thickness Detector.

Description:

The following LEDs turn ON when one of the Original-Sensors is activated, or when one or both Adjustment Sliders for Media Thickness are pulled out from Normal position:

Actuator	LED
Original Entry Sensor	Ready (Green)
Original Exit Sensor	Ready (Green)
Adjustment Slider for Media Thickness	Wait

10.1.5 Test 5, Lamp Test

Purpose: To test the Lamp and associated electronics.

Description: A message on the screen will inform whether the **Lamp** is turned ON or OFF (Lamp power is turned ON/OFF) and whether the **Light** is ON/OFF (Light is detected or not). The Lamp is delayed approx. 2 seconds when switched ON.

10.1.6 Test 6, Motor Test

Purpose: To test the Stepper Motor and associated electronics.

Description: From the menu the motor speed and the direction of rotation can be selected.

10.1.7 Test 7, Complete Hardware Test

Purpose: To test various functions on the SUC and CBE/CBF-Boards.

10.1.8 Test 9, Camera Adjustment

See also Test 27, Camera Adjustment Wizard

Purpose: To support CCD-Camera evaluation and adjustments.

Description: Test 9 contains a “Software Oscilloscope” for check and adjustment of the cameras. The following functions can be selected from the Test Program Menu.

- Uncorrected or Corrected Light Profile
- Red, Green, Blue, or Gray Color Channel (Selections depend on scanner model)
- Special Detail Views for Light Profile, Scan Width, and Vertical Positioning
- Forward / Reverse controls for the Camera Motor
- Save screen images
- Print screen images
- Load saved images

The contents of Detail Views is marked on the upper overview window by red vertical lines. The continuous lines refer to the left Detail View and the dashed lines to the right Detail View.

10.1.9 Test 11, Stitching and Vertical Alignment

Purpose: Performs Automatic Vertical Alignment and Horizontal Stitching.

Description: After Test 11 has been started:

- Insert SM Calibration Sheet
- Select Vertical Alignment to align the cameras
- Select Horizontal Stitching to stitch the cameras

The screen image may be saved or printed.

Test 11 allows manual setting of the Stitch Values. The Stitch Values are stored in the Flash Memory on the SUC-Board.

The Vertical Alignment may be adjusted manually by controlling the Camera Motor from the control field '<<dddd>>'. The two buttons marked '<<' respectively '>>' are used to start the motor and to determine the direction of rotation. When stated, the motor runs for dddd milliseconds as entered into the control field.

10.1.10 Test 12, Adjustment of Y-Axis Scaling

Purpose: To adjust the Y-Axis Scaling.

Description: The scaling (dpi) in the mechanical scan direction (Y-Axis) depends on the speed of the stepper motor relative to the scanline Exposure Time. The default motor speed can be changed $\pm 1\%$, either from Test 12 or by using the 'Scanner Setup/Correction factor ...' option of WIDEimage.

The correction factor is stored in the Flash Memory on the SUC-Board.

10.1.11 Test 13, Switch Scanner to Test Mode

Purpose: To switch the scanner back to Test Mode. Useful if the scanner gets out of Test Mode, e.g. if it has to be turned OFF/ON during troubleshooting.

10.1.12 Test 20, Noise Test

Purpose: To detect and locate the possible cause (dust, dirt, scratches,..) of vertical lines running from top to bottom of the scanned image.

Description: Test 20 scans the White Calibration Area of the SM Calibration Sheet and displays, for each color channel, the graytone values of each separate pixel averaged over the scanned band.

The displayed image of the SM Calibration Sheet will be superimposed by low level noise caused by the CCD chip, and larger spikes most likely caused by dust, dirt, scratches, or similar defects on the Glass Plate. In rare cases, larger spikes may be caused by dust, dirt, or pixel faults on the CCD chip.

The positions of larger spikes are shown by the numbers (cm or inch units) opposite to the spikes. The numbers refer to the Sideload-ruler on the scanner.

Larger spikes going downwards are often caused by dust, dirt, scratches, or similar defects on the Glass Plate and may be removed by cleaning the Glass Plate.

Downward spikes often show up as darker vertical lines in the scanned image, see Fig. 10-1, page 176.

Larger spikes going upwards are often caused by dust or dirt present on the Glass Plate during the last calibration with Scanner Maintenance. These defects are memorized by the Light Profiles stored in Flash Memory and can only be removed by cleaning of the Glass Plate followed by running Scanner Maintenance again.

Upward spikes show up as very bright vertical lines in the scanned image, see Fig. 10-1, page 176.

White vertical lines in the scanned image may be found even if Noise Test shows a perfectly 'clean' scanner. In this case, the cause may be white dust or particles on the backside of the Glass Plate having the same color as the white background.

In this case, the Light Profiles of SCANtest 6, Test 9 may show upwards going spikes when a dark original is placed in the scan-area.

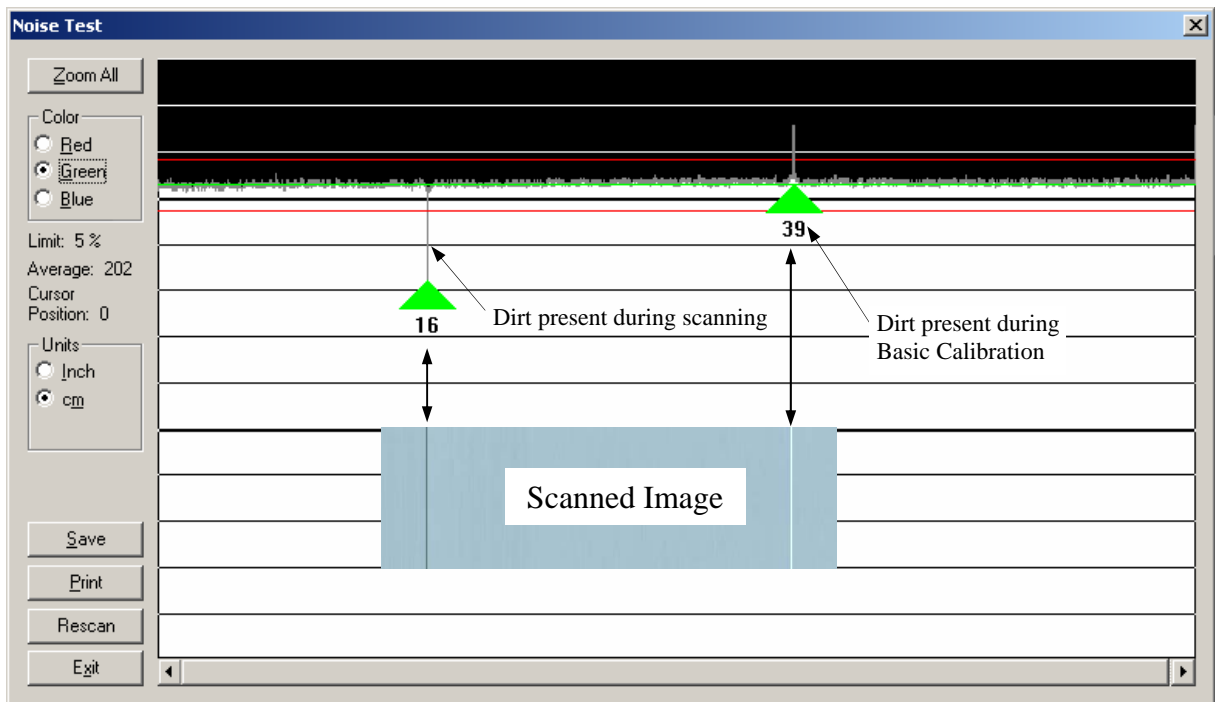

Fig. 10-1 Noise Test, Example

10.1.13 Test 21, SCANDump

Purpose: To create a file, SCANDump.con, which contains Light Profiles and other scanner data for diagnostics purposes.

Description: The file SCANDump.con will be placed in the directory pointed to by the SET TEMP environment variable.

The files contained in SCANDump.con may be unpacked by SCANview 6 by double clicking on SCANDump.con.

The unpacked Light Profiles may be viewed by SCANview 6. If other files are included use an appropriate reader or viewer.

10.1.14 Test 27, Camera Adjustment Wizard

See also Test 9, Camera Adjustment

Purpose: To support CCD-Camera adjustments.

Description: The Camera Wizard provides a guide for a complete adjustment of all cameras of the actual scanner, just start Test 27 and follow the instructions given by the Wizard.

10.1.15 Test 28, Original Guide Sensor Test

Purpose: To support check and adjustment of the sensors located in the Original Guide with ATAC.

Description: see Section 3.15, page 69.

10.1.16 Test 30, Calibrate ATAC

This test applies only to scanners with ATAC and has been implemented from firmware release 50 (Build 799) and SCANtest 6 version 7.0.1.

Purpose: To set the current level at which the ATAC will stop if something is preventing the guide plate from moving.

The first scanners shipped had a predefined current level but with this new test the ATAC system adapts to the actual friction level of the system.

To calibrate the ATAC simply run Test 30. If the calibration fail this is most likely because the tacho sensor is not functioning. In this case please refer to FSG/TSB/003 which describes how to correct this problem.

11. Wiring Diagrams

This Section contains the following wiring diagrams:

- Fig. 11-1 COUGAR 25 Primary Wiring, page 179
- Fig. 11-2 COUGAR 25, Secondary Wiring, page 180
- Fig. 11-3 CHAMELEON 25, Primary Wiring, page 181
- Fig. 11-4 CHAMELEON 25, Secondary Wiring, page 182
- Fig. 11-5 COUGAR 36, Primary Wiring, page 183
- Fig. 11-6 COUGAR 36, Secondary Wiring, page 184
- Fig. 11-7 CHAMELEON 36, PREMIER 36, Primary Wiring, page 185
- Fig. 11-8 CHAMELEON 36, PREMIER 36, Secondary Wiring, page 186
- Fig. 11-9 CHROMA Tx 40, CRYSTAL Tx 40, Primary Wiring, page 187
- Fig. 11-10 CHROMA Tx 40, CRYSTAL Tx 40, Secondary Wiring, page 188
- Fig. 11-11 MAGNUM XL 54, Primary Wiring, page 189
- Fig. 11-12 MAGNUM XL 54, Secondary Wiring, page 190
- Fig. 11-13 COUGAR Tx 36, CHAMELEON Tx 36, PREMIER Tx 36, Primary Wiring, page 191
- Fig. 11-14 COUGAR Tx 36, CHAMELEON Tx 36, PREMIER Tx 36, Secondary Wiring, page 192

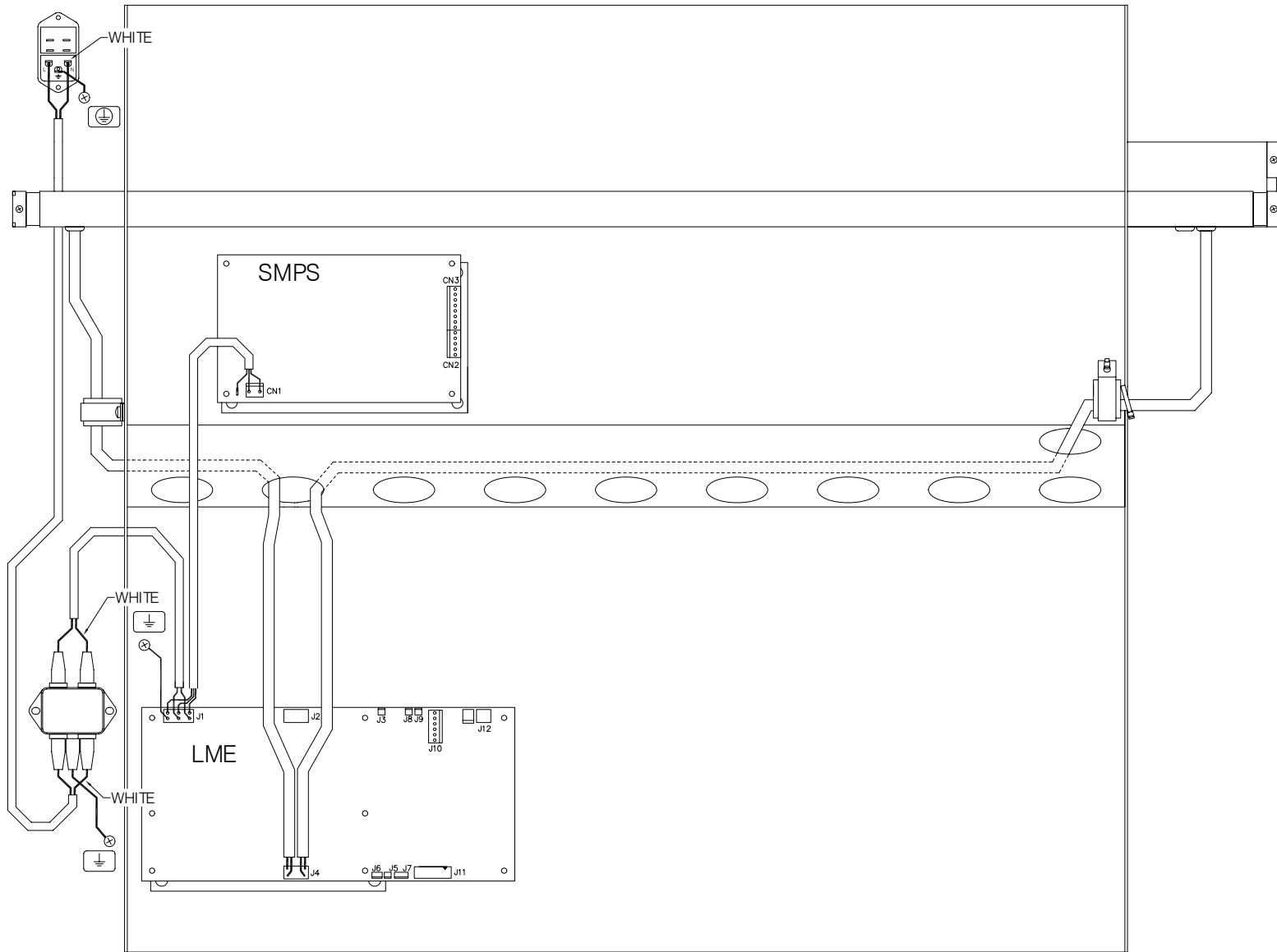

Fig. 11-1 COUGAR 25 Primary Wiring

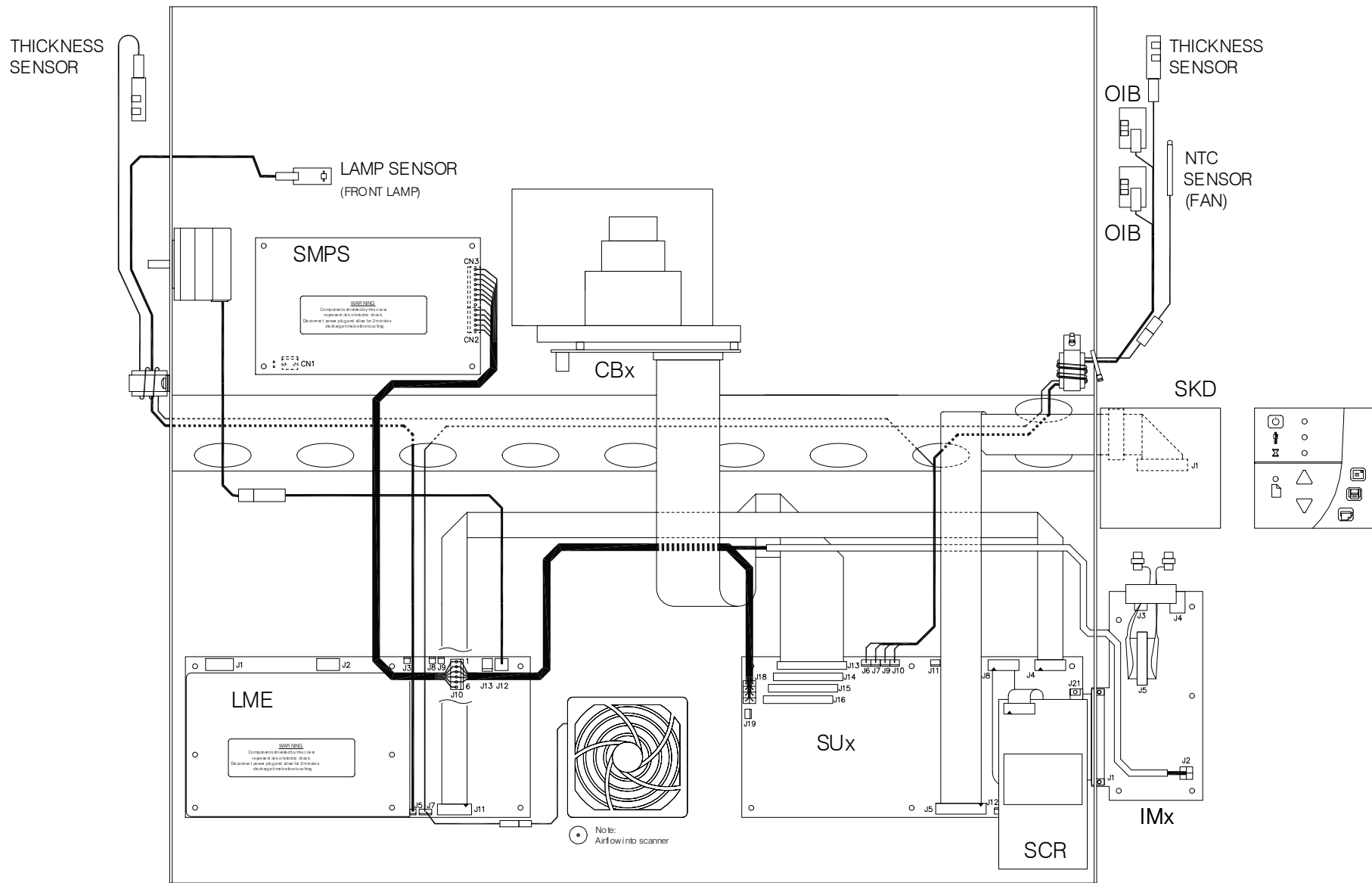

Fig. 11-2 COUGAR 25 Secondary Wiring

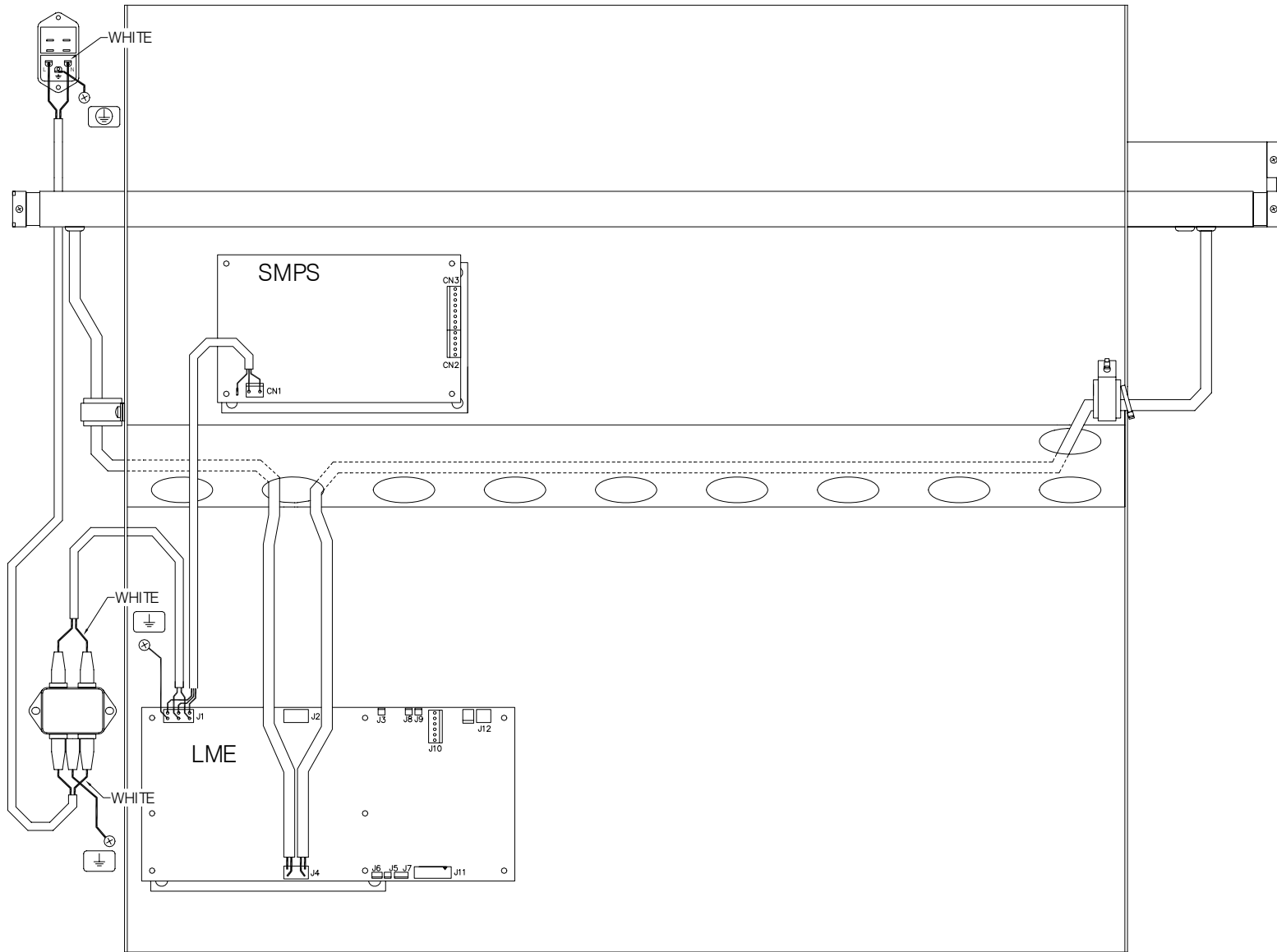

Fig. 11-3 CHAMELEON 25 Primary Wiring

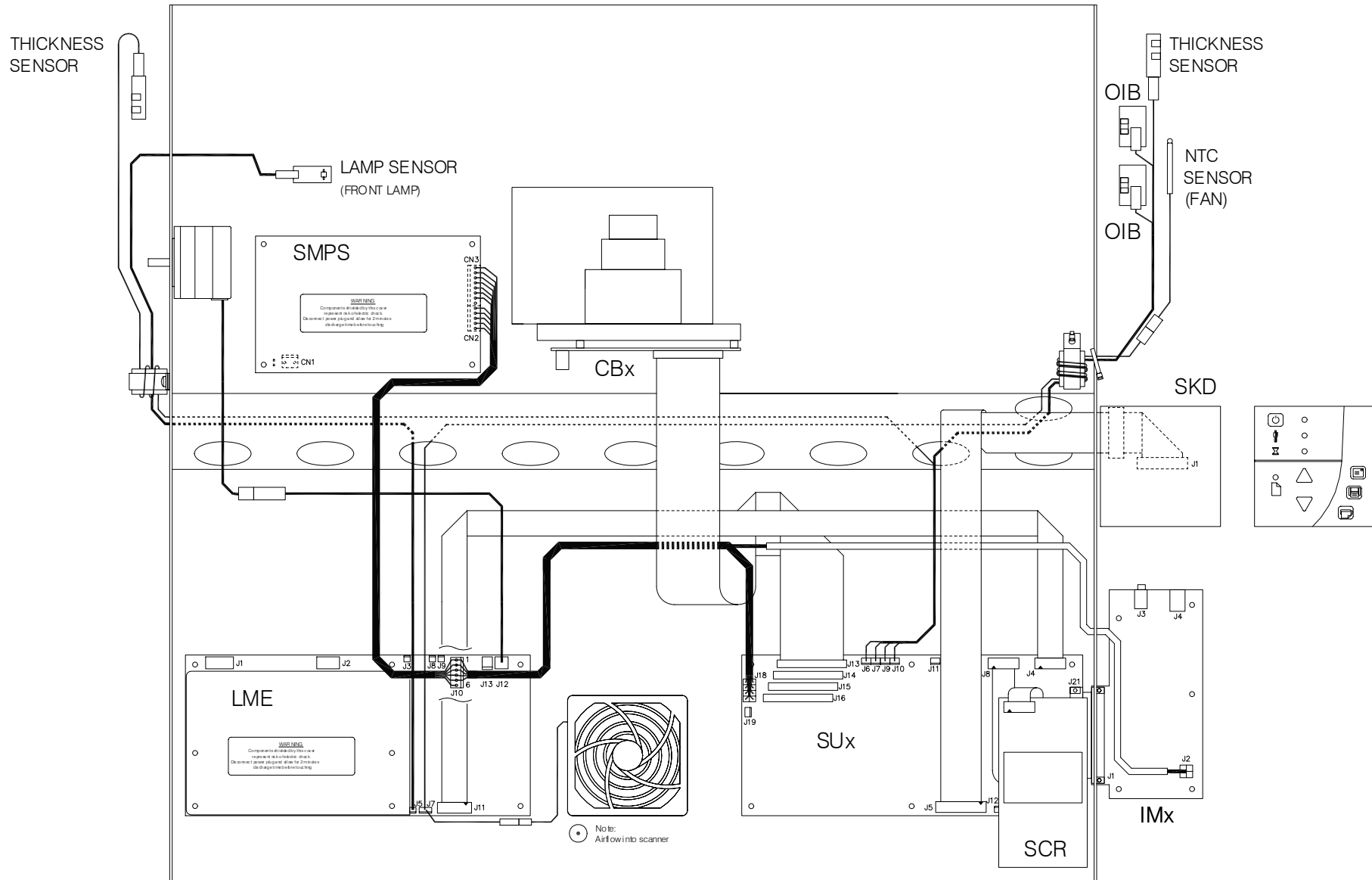

Fig. 11-4 CHAMELEON 25 Secondary Wiring

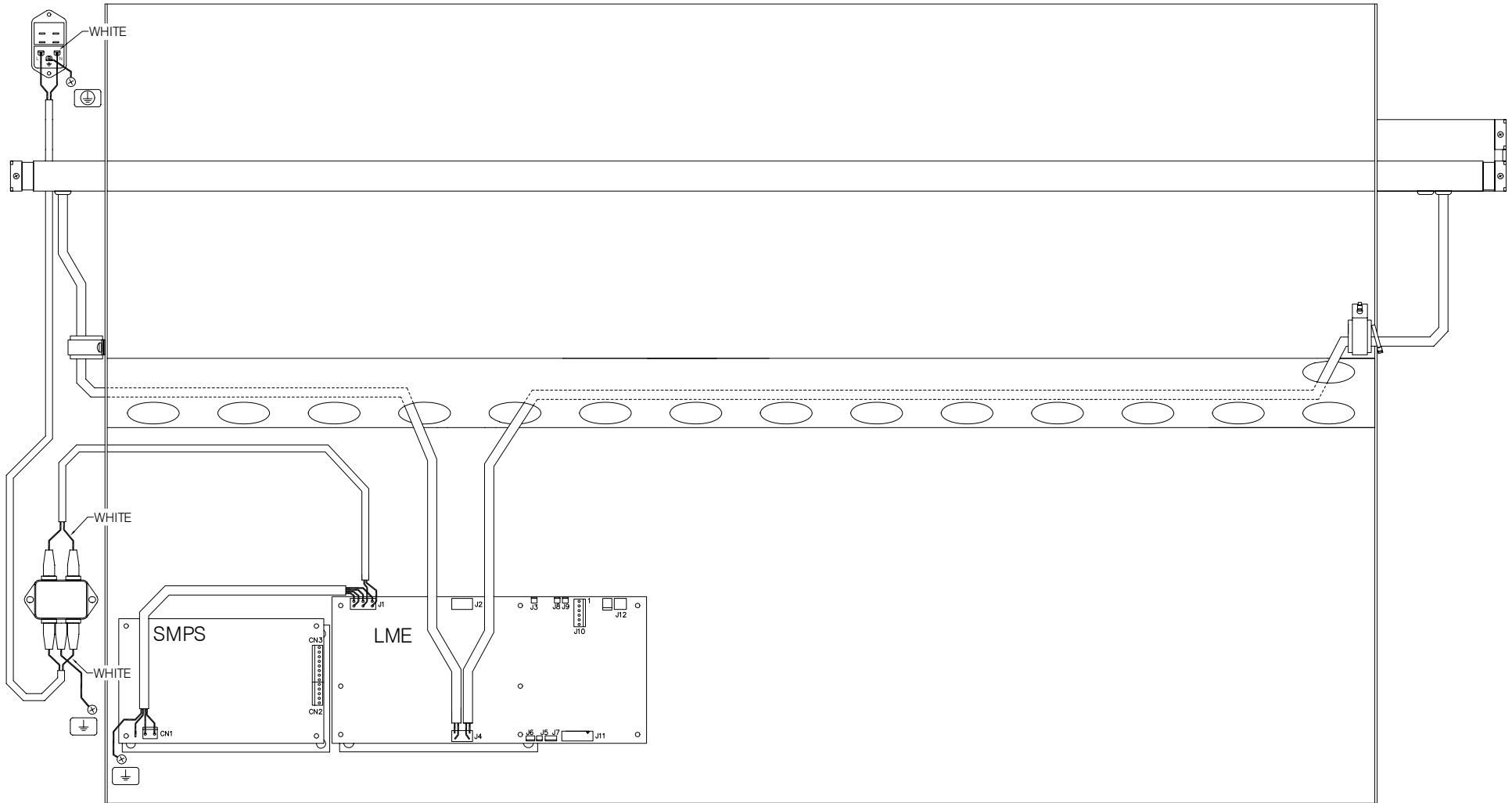

Fig. 11-5 COUGAR 36 Primary Wiring

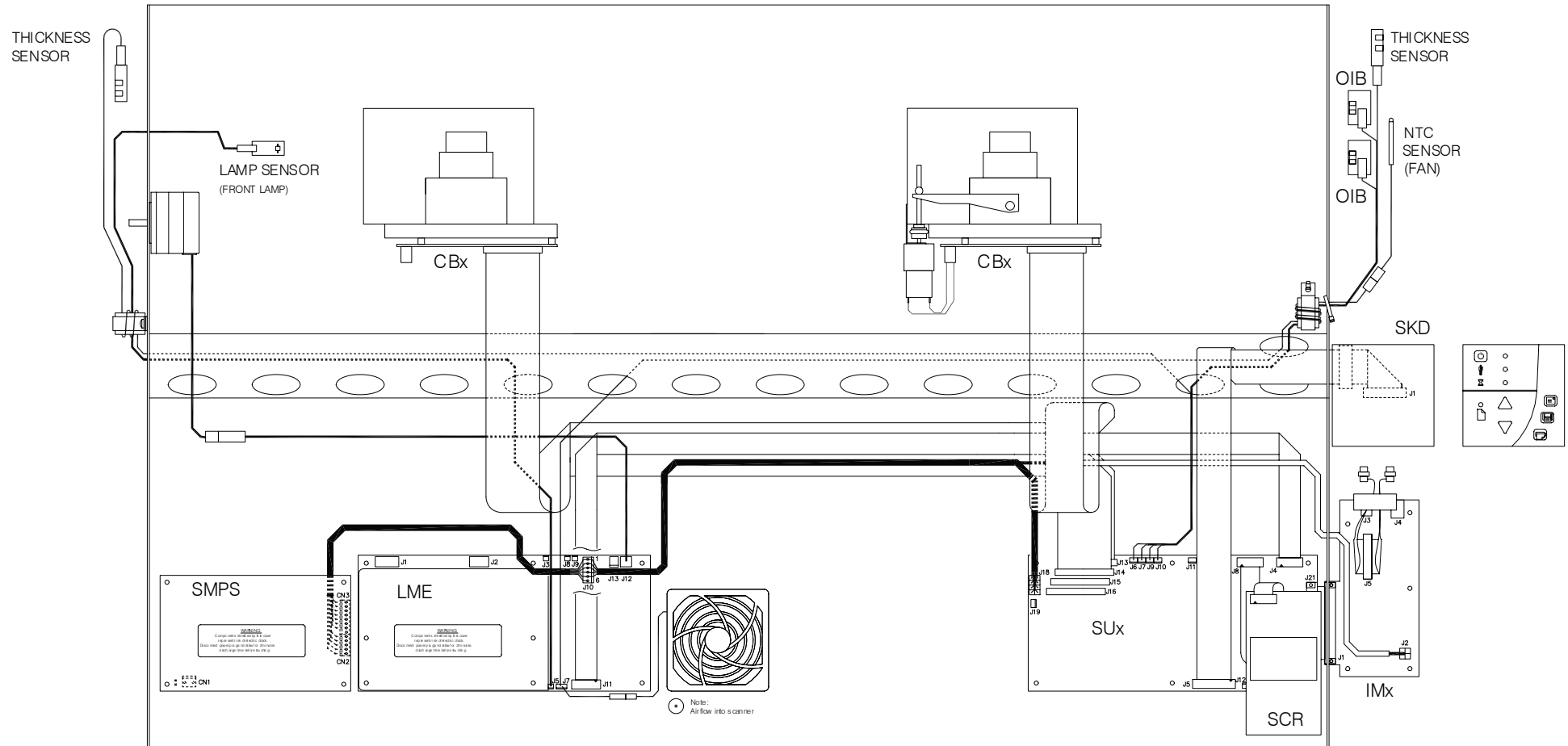

Fig. 11-6 COUGAR 36 Secondary Wiring

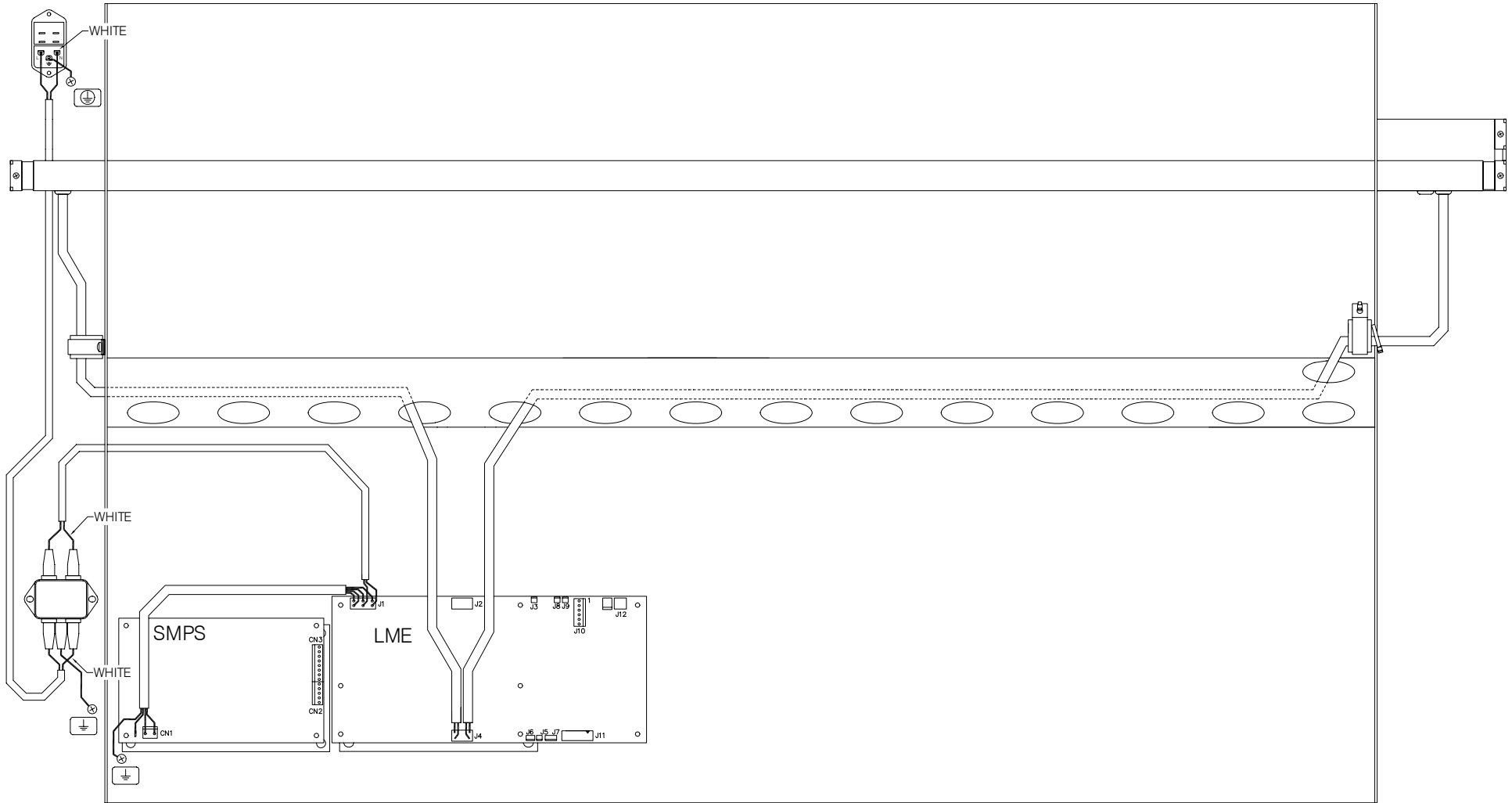

Fig. 11-7 CHAMELEON 36, PREMIER 36, Primary Wiring

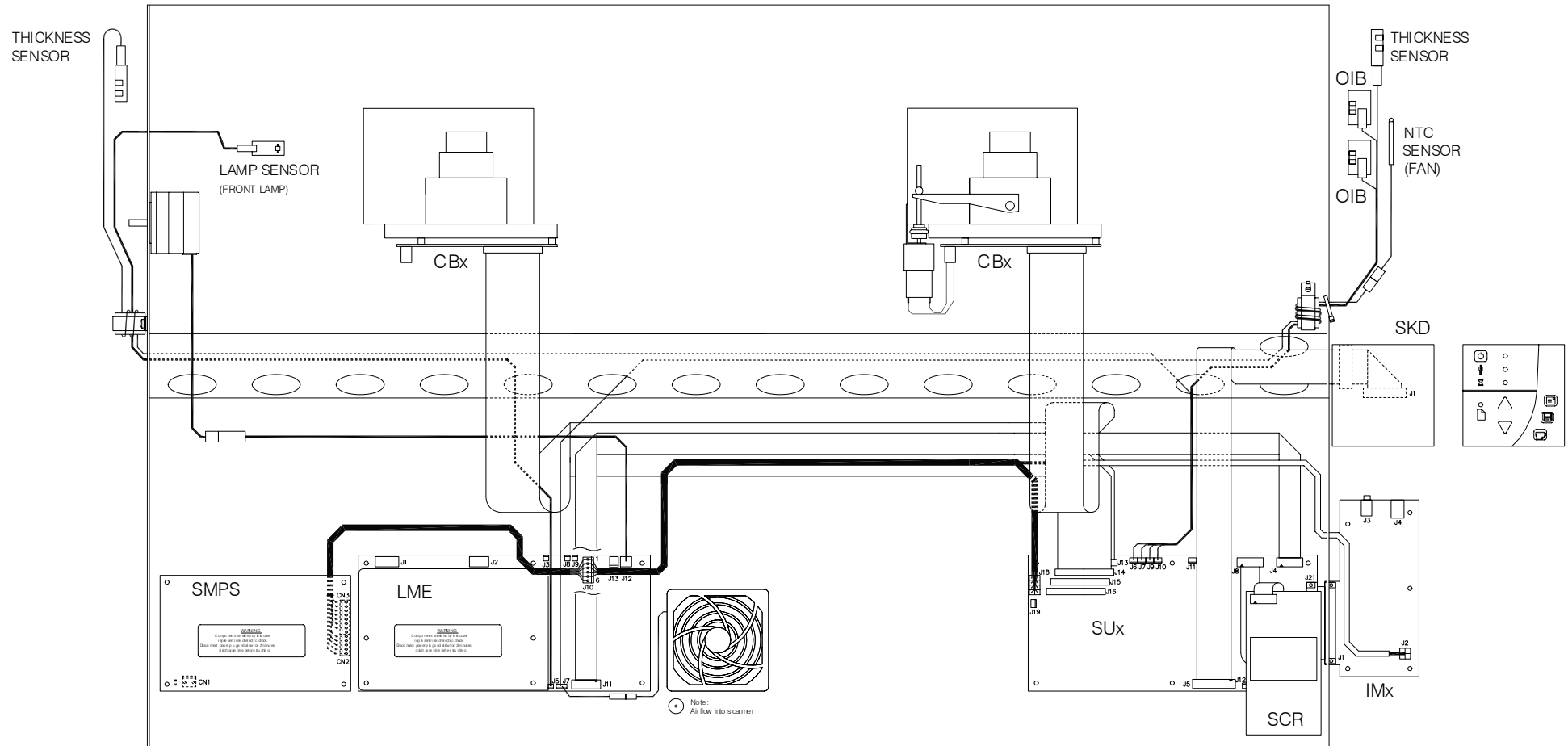

Fig. 11-8 CHAMELEON 36, PREMIER 36, Secondary Wiring

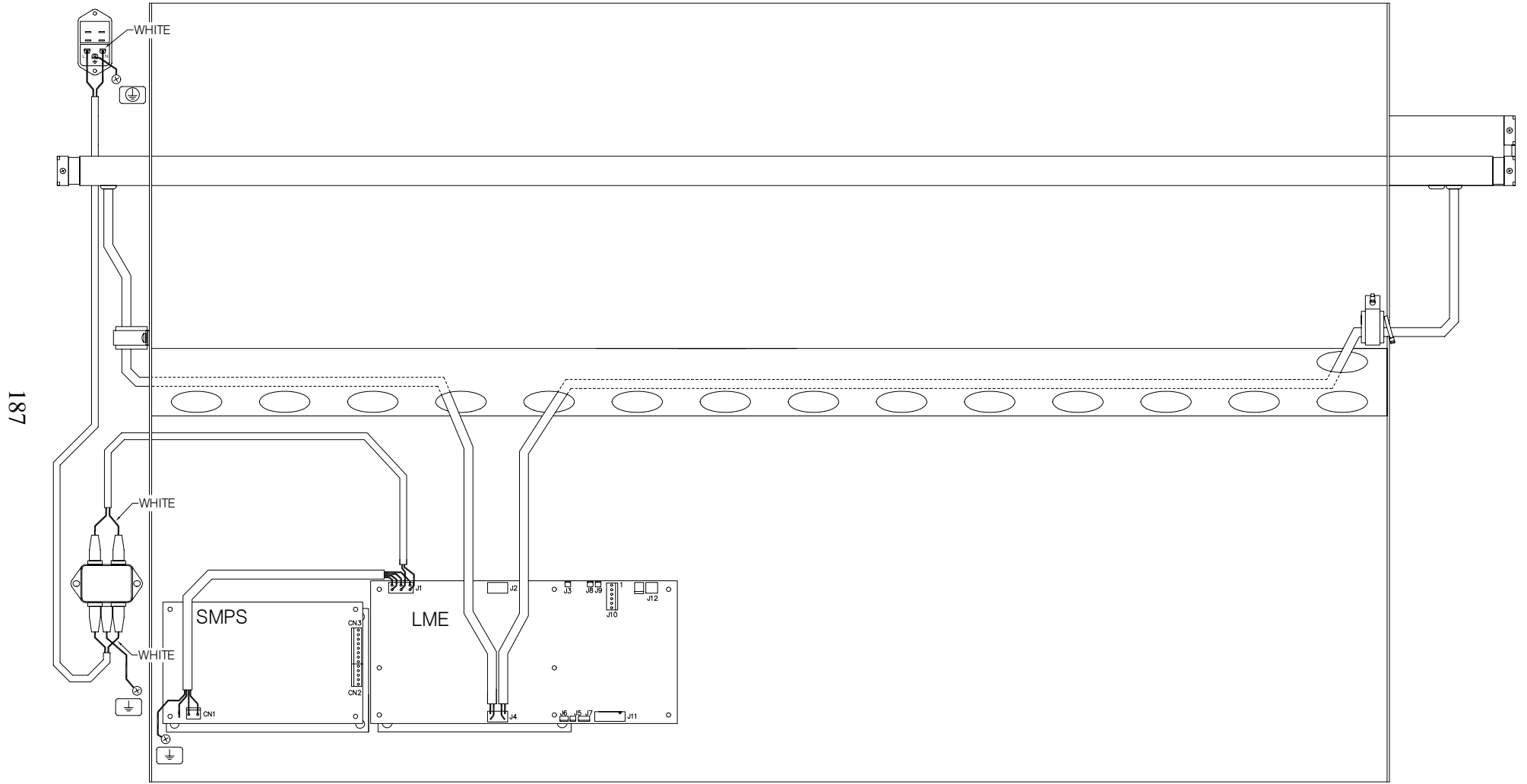

Fig. 11-9 CHROMA Tx 40, CRYSTAL Tx 40, Primary Wiring

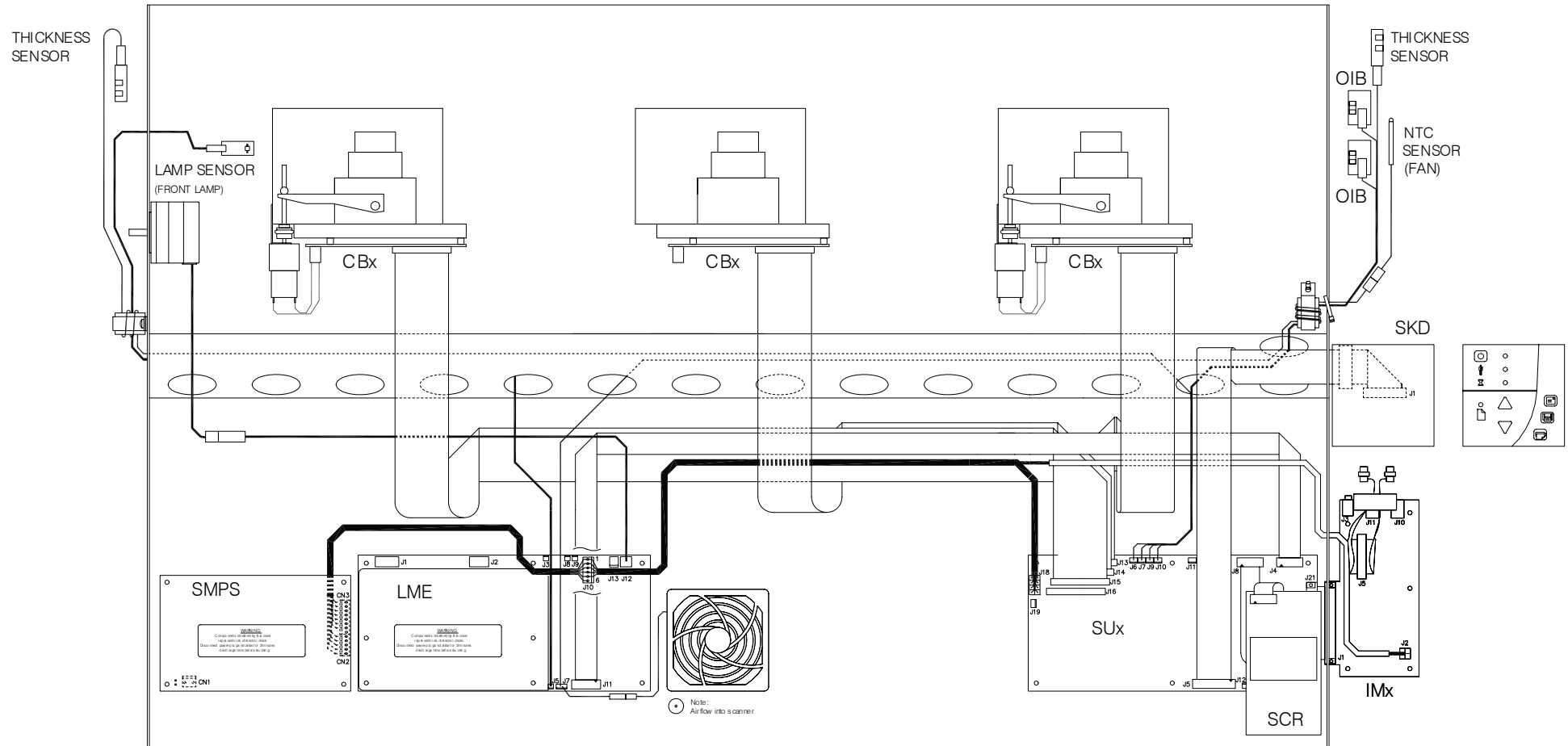

Fig. 11-10 CHROMA Tx 40, CRYSTAL Tx 40, Secondary Wiring

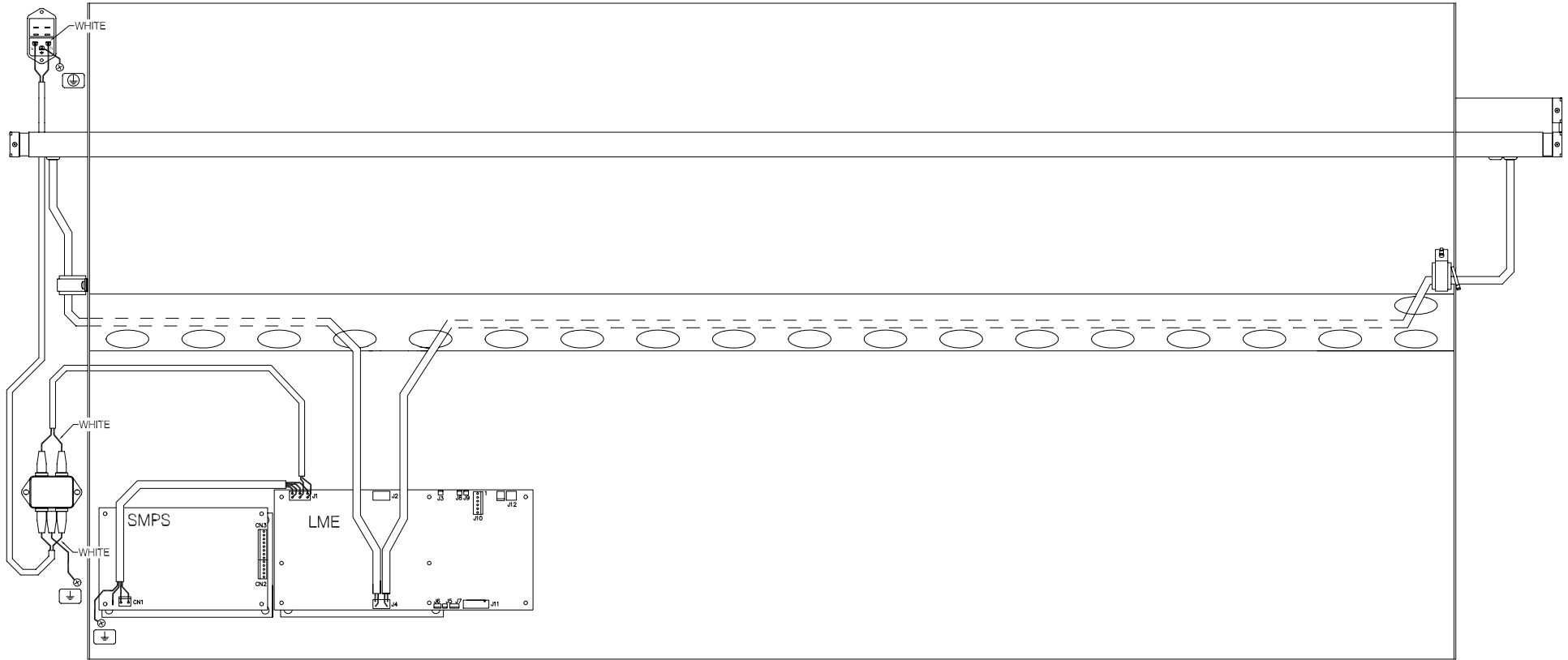

Fig. 11-11 MAGNUM XL 54, Primary Wiring

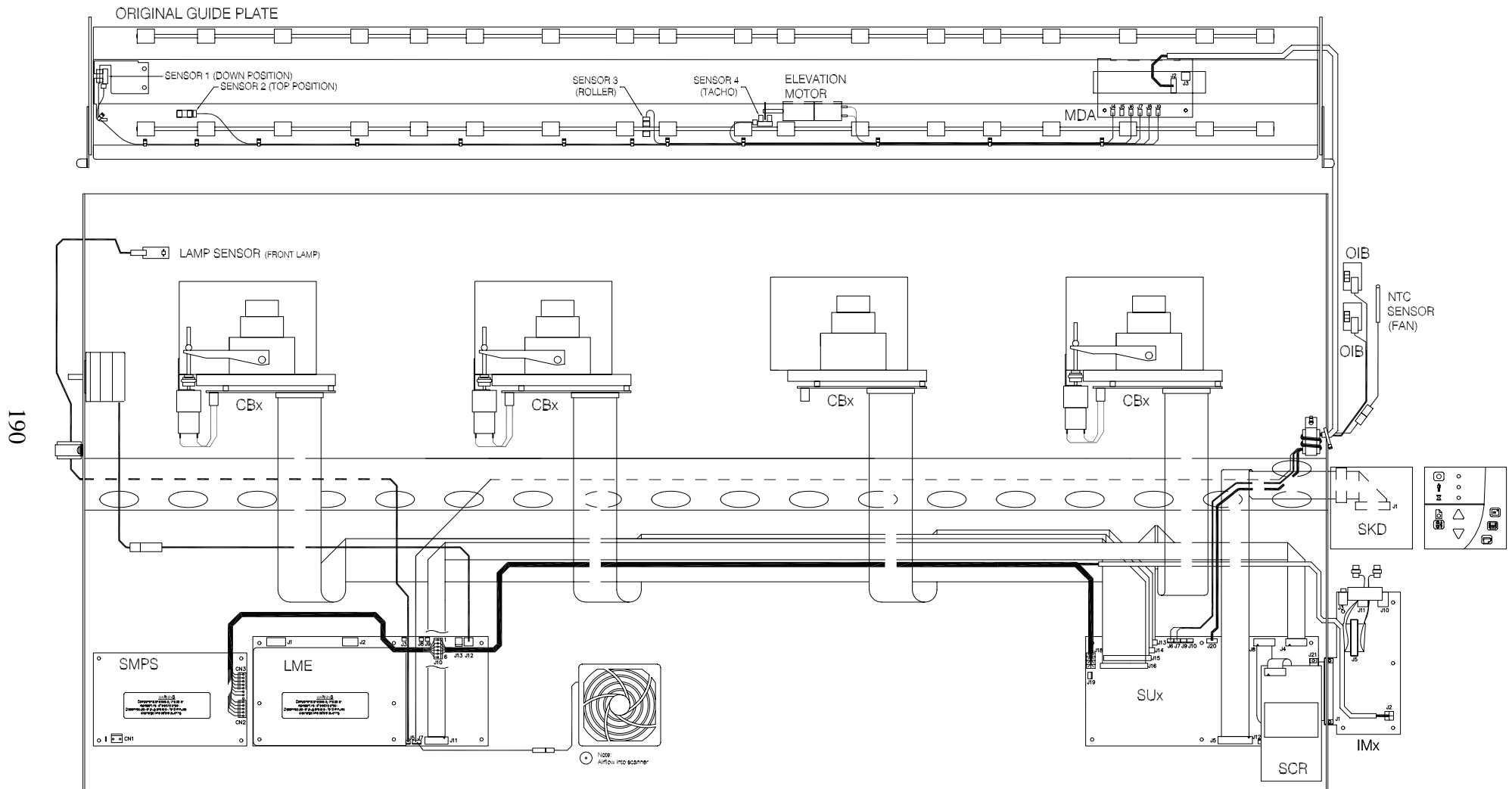
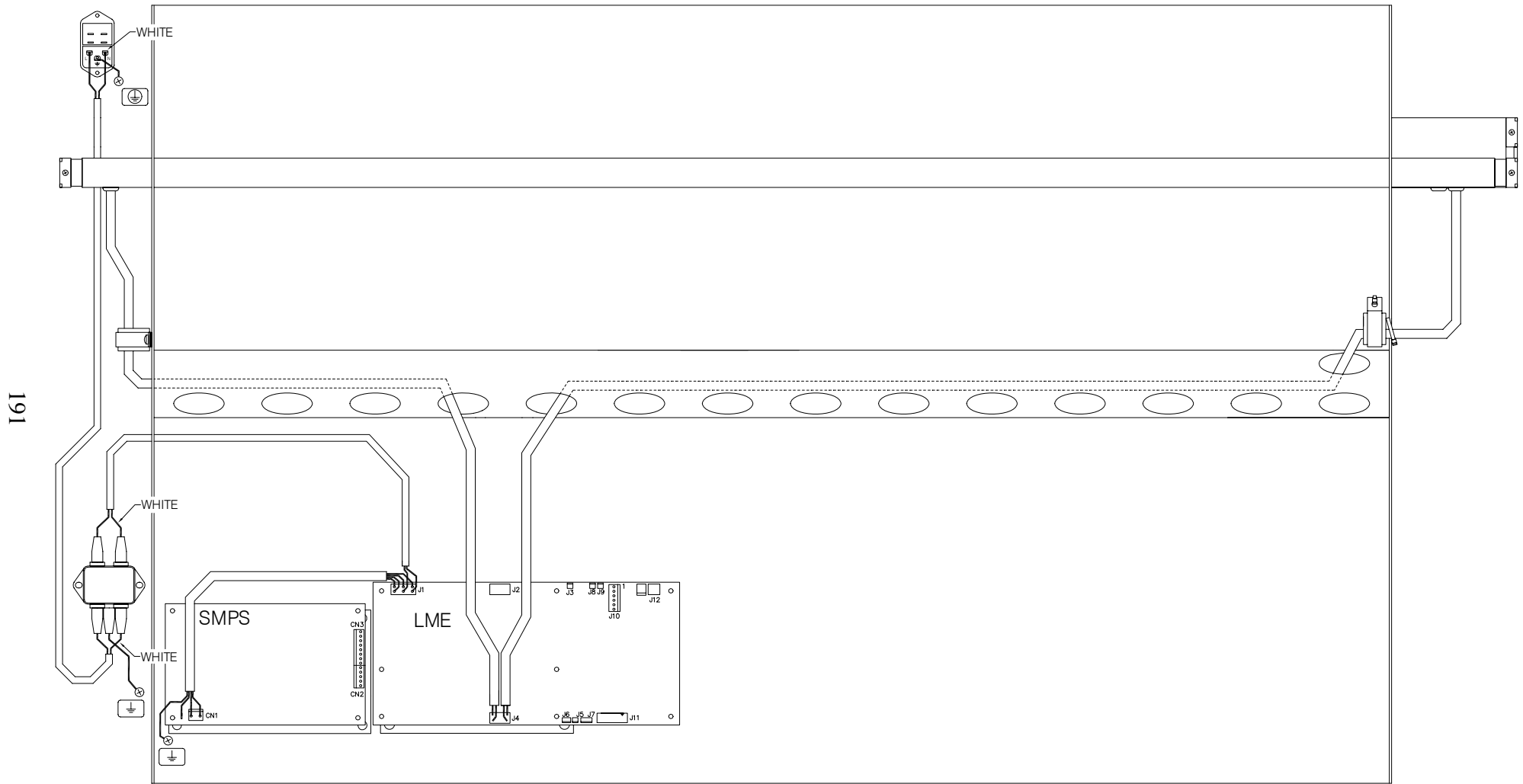

Fig. 11-12 MAGNUM XL 54, Secondary Wiring



191

Fig. 11-13 COUGAR Tx 36, CHAMELEON Tx 36, PREMIER Tx 36, Primary Wiring

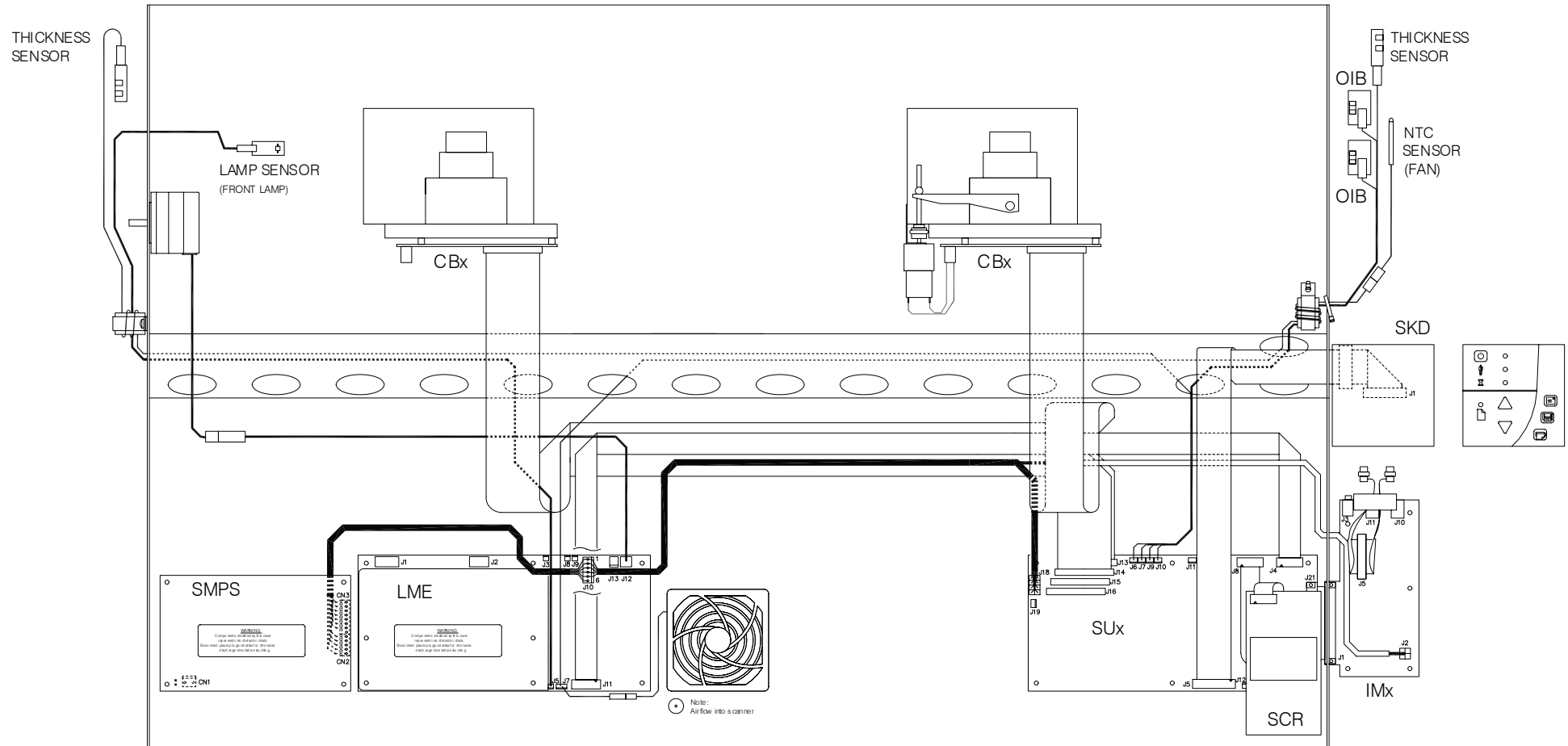

Fig. 11-14 COUGAR Tx 36, CHAMELEON Tx 36, PREMIER Tx 36, Secondary Wiring

12. Special Service Tools

Adjustment and Test Patterns:

Scanner Model:	COUGAR 25 CHAMELEON 25	COUGAR 36 CHAMELEON 36 PREMIER 36	CHROMA Tx 40 CRYSTAL Tx 40	COUGAR Tx 36 CHAMELEON Tx 36 PREMIER Tx 36	MAGNUM XL 54
Optical Adjustment Pattern, 25", 1 Cam. p/n 6779D105R01	×				
Optical Adjustment Pattern, 36", 2 Cam. p/n 6779D127R01				×	
Optical Adjustment Pattern, 40", 2 Cam. p/n 6779D107R01		×			
Optical Adjustment Pattern, 40", 3 Cam. p/n 6779D102R01			×		
Optical Adjustment Pattern, 54", 4 Cam. p/n 6779D130R01					×
Focus Pattern, 25" p/n 6779D215R01	×				
Focus Pattern, 40" p/n 6779D216R01		×	×	×	
Focus Pattern, 54" p/n 6779D228R01					×
SM Calibration Sheet, 25" p/n 6799D115R01	×				
SM Calibration Sheet, 40" p/n 6799D116R01		×	×	×	
SM Calibration Sheet, 54" p/n 6799D165					×

Special Tools:

Scanner Model:	COUGAR 25 CHAMELEON 25	COUGAR 36 CHAMELEON 36 PREMIER 36	CHROMA Tx 40 CRYSTAL Tx 40	COUGAR Tx 36 CHAMELEON Tx 36 PREMIER Tx 36	MAGNUM XL 54
Belt Tension Gauge p/n 6779D120	×	×	×	×	×
Adjustment Tools for Roller Sensor (2 pcs.) p/n 6779D133R01					×
Adjustment Tools for Top Position Sensor (2 pcs.) p/n 6779D246R01					×

For cleaning of the Glass Plate and the White Background Plate use:

- Ordinary window-cleaning detergent
- Soft lint-free cloth
- Microfibre Cleaning Cloth (as the cloth supplied with scanner)

For cleaning of the CCD use:

- A soft lint-free cloth and ethyl alcohol be careful not to scratch the glass.

TITLE: Addendum to FSG/MTM/001
CHROMA XL 42
CRYSTAL XL 42
COUGAR Sx 25
CHAMELEON Sx 25

DOC. NO.: FSG/MTM/002

PREPARED BY: LM/BN

AUTHORIZED: JR

DISTRIBUTION: Tegningsarkiv, Svendborg (1)
PT, Svendborg (1)
DD (1)

ISSUE REVISION: 1.1
DATE: 2006-06-11

This document is the property of Contex A/S. The data contained herein, in whole or in part, may not be duplicated, used or disclosed outside the Recipient for any purpose other than to conduct technical evaluation. This restriction does not limit the Recipients right to use information contained in the data if it is obtained from another source without restriction.



Document Revision Record

DRR

REV.	DATE	CHANGED BY	PAGES AFFECTED	BRIEF DESCRIPTION OF CHANGE
1.0	040705	LM/BN	All	Original issue of document
1.1	060511	LM	All	3.12, Adjustment of Original Sensors: New description for XL 42 Fig. 2-1 & 2-2 Block Diagrams: Paper sensor connections corrected Screen dumps for camera adjustments added Minor corrections

Table of Contents

1.	Introduction.....	5
2.	General Overview	5
2.1	COUGAR SX 25 AND CHAMELEON SX 25	6
2.2	CHROMA XL 42 AND CRYSTAL XL 42.....	8
3.	Electrical Tests and Adjustments	10
3.1	LMF (USED IN XL 42 SCANNERS)	10
3.1.1	DC Voltages	10
3.1.2	Lamp Driver	10
3.1.3	Stepper Motor Driver	10
3.1.4	The LMF board is designed to work with calibrated Lamp Cartridges which means that there Functional Test	10
3.1.5	Fuses	11
3.1.6	Markings	11
3.1.7	Jumper Settings	11
3.1.8	Hints	11
3.2	CBI (USED IN SX 25 SCANNERS).....	13
3.2.1	DC Voltages	13
3.2.2	Adjustments	13
3.2.3	Functional Test	13
3.2.4	Markings	13
3.2.5	Jumper Settings	13
3.2.6	Hints	13
3.3	CBK (USED WITH XL 42 SCANNERS).....	15
3.3.1	DC Voltages	15
3.3.2	Adjustments	15
3.3.3	Functional Test	15
3.3.4	Markings	15
3.3.5	Jumper Settings	15
3.3.6	Hints	15
3.4	SUCM AND SUCL.....	17
3.4.1	Markings	17
3.4.2	Hint	17
3.5	SKD	17
3.5.1	Markings	17
3.5.2	Switch Setting (Scanner ID)	17
3.6	IME (USED IN XL 42 SCANNERS)	18
3.6.1	DC Voltages	18
3.6.2	Adjustments	18
3.6.3	Functional Test	18
3.6.4	Markings	18
3.7	IMF (USED IN SX 25 SCANNERS)	20
3.7.1	DC Voltages	20
3.7.2	Adjustments	20
3.7.3	Functional Test	20
3.7.4	Markings	20
3.8	CRB (USED IN XL 42 SCANNERS)	22
3.8.1	DC Voltages	22
3.8.2	Functional Test	22
3.8.3	Markings	22
3.8.4	DIP Switch Setting	22

3.8.5	Signal LED on the CRB Board	23
3.9	MDA (USED IN XL 42 SCANNERS)	25
3.9.1	DC Voltages	25
3.9.2	Functional Test	25
3.9.3	Markings	25
3.10	LCA (USED IN XL 42 SCANNERS)	26
3.11	CHECK AND ADJUSTMENT OF ORIGINAL GUIDE SENSORS (ATAC) (XL 42 ONLY)	26
3.12	ADJUSTMENT OF ORIGINAL SENSORS	26
4.	CCD Camera	27
4.1	SETTING THE INITIAL POSITION OF THE VERTICAL ALIGNMENT ARM	27
4.2	ADJUSTING THE CAMERA TILT	27
4.3	CCD-CAMERA CHECK AND ADJUSTMENT	29
4.3.1	Check of Light Profiles	30
4.3.2	Check and Adjustment of Focus	32
4.3.3	Check and Adjustment of Scan-Width	34
4.3.4	Check and Adjustment of CCD-Centering	35
4.3.5	Check and Adjustment of Vertical Positioning	36
4.3.6	Final Check	36
5.	Special Service Tools	41
6.	Wiring Diagrams	42

List of Figures

Fig. 2-1	COUGAR Sx 25 and CHAMELEON Sx 25 Block Diagram	7
Fig. 2-2	CHROMA XL 42 and CRYSTAL XL 42 Block Diagram	9
Fig. 3-1	LMF Component Layout	12
Fig. 3-2	CBI Component Layout	14
Fig. 3-3	CBK Component Layout	16
Fig. 3-4	IME Component Layout	19
Fig. 3-5	IMF Component Layout	21
Fig. 3-6	CRB Component Layout	24
Fig. 3-7	MDA Component Layout	25
Fig. 4-1	CCD Camera	28
Fig. 4-2	Sx 25 Uncorrected Light Profile	30
Fig. 4-3	Sx 25 Corrected Light Profile	30
Fig. 4-4	XL 42 Uncorrected Light Profile	31
Fig. 4-5	XL 42 Corrected Light Profile	31
Fig. 4-6	Sx 25 Focus Signal (Blue Channel)	32
Fig. 4-7	XL 42 Focus Signal (Blue Channel)	33
Fig. 4-8	XL 42 Focus Signal (Red and Green Channel)	33
Fig. 4-9	Sx 25, Scan-Width, CCD-Centering and Vertical Positioning	37
Fig. 4-10	XL 42 Camera A: Scan-Width, CCD-Centering and Vertical Positioning	37
Fig. 4-11	XL 42 Camera B: Scan-Width, CCD-Centering and Vertical Positioning	38
Fig. 4-12	XL 42 Camera B: Scan-Width, CCD-Centering and Vertical Positioning	38
Fig. 4-13	Optical Adjustment Pattern, 1 Camera, 25"	39
Fig. 4-14	Optical Adjustment Pattern, 3 Camera, 42"	40
Fig. 6-1	Sx 25 Primary Wiring	43
Fig. 6-2	Sx 25 Secondary Wiring	44
Fig. 6-3	XL 42 Primary Wiring	45
Fig. 6-4	XL 42 Secondary Wiring	46

1. Introduction

This document is an addendum to FSG/MTM/001 which gives a short introduction to the following new scanner models:

GQ67D (COUGAR Sx 25)
 GR67D (CHAMELEON Sx 25)
 GN67D (CHROMA XL 42)
 GP67D (CRYSTAL XL 42)

It primary contains component layout drawings for any new boards used in these scanners as well as describes how to set the basic vertical position of the new camera used in the XL 42 models.

2. General Overview

The table below gives a general overview of which boards are used in which scanners and where to find the description/layout for these.

Model	GN67D	GP67D	GQ67D	GR67D	Comments
Trade Name	CHROMA XL 42	CRYSTAL XL 42	COUGAR Sx 25	CHAMELEON Sx 25	
Type	3C42"	3C42"	1C25"	1C25"	
CCD	4x 7500	4x 7500	3 x 10680	3 x 10680	
Optical resolution	508	508	424	424	
ATAC	YES	YES	NO	NO	
Power Supply	PPQ-1003D	PPQ-1003D	PPQ-1003D	PPQ-1003D	Refer to FSG/TSM/001
Lamp Driver	LMFA	LMFA			NEW *
Lamp Driver			LMEA	LMEA	Refer to FSG/TSM/001
Camera Board	CBKA	CBKA			NEW *
Camera Board			CBIA	CBIA	NEW *
Controller Board	SUCM		SUCM		NEW *
Controller Board		SUCL		SUCL	NEW *
Keyboard	SKDG	SKDG			NEW *
Keyboard			SKDA	SKDA	Refer to FSG/TSM/001 Keyboard switch settings in this document
Interface Board	IMEA	IMEA			NEW *
Interface Board			IMFA	IMFA	NEW *
Card Reader Board	CRBA	CRBA			NEW *
Card Reader Board			SCRA	SCRA	Refer to FSG/TSM/001
Motor Driver Board	MDAC	MDAC	N/A	N/A	NEW *
Lamp Cartridge	LCAB	LCAB	N/A	N/A	NEW *

* Component layouts and test voltages found in this document

2.1 COUGAR Sx 25 and CHAMELEON Sx 25

The Block Diagram is shown in:

Fig. 2-1 COUGAR Sx 25 and CHAMELEON Sx 25 Block Diagram, page 7

The COUGAR Sx 25 and CHAMELEON Sx 25 scanner range consists of:

Model:	GQ67D		GR67D	
Trade name:	COUGAR Sx 25	COUGAR Sx 25 PLUS	CHAMELEON Sx 25	CHAMELEON Sx 25 PLUS
No. of cameras:	1	1	1	1
CCD	3 x 10680	3 x 10680	3 x 10680	3 x 10680
Chassis:	25 inches	25 inches	25 inches	25 inches
Scan width:	25 inches	25 inches	25 inches	25 inches
Computer interface:	USB/IEEE 1394	USB/IEEE 1394	USB/IEEE 1394	USB/IEEE 1394
Scan mode:	Color Monochrome	Color Monochrome	Monochrome	Color Monochrome
Optical resolution:	424 dpi	424 dpi	424 dpi	424 dpi
SmartCard:	BASIC	PLUS	BASIC	PLUS

Each of the two models GQ67D and GR67D are marketed with two different levels of functionality, such as image resolution, scanning speed, scanning modes, etc:

Model: GQ67D (USB and IEEE 1394 interface)
 Trade names: COUGAR Sx 25 (basic level of functionality)
 COUGAR Sx 25 PLUS (enhanced level of functionality)

Model: GR67D (USB and IEEE 1394 interface)
 Trade names: CHAMELEON Sx 25 (basic level of functionality)
 CHAMELEON Sx 25 PLUS (enhanced level of functionality)

The basic versions of the scanners (COUGAR Sx 25 and CHAMELEON Sx 25) may be field upgraded to the enhanced versions (COUGAR Sx 25 PLUS and CHAMELEON Sx 25 PLUS) by replacing the BASIC Smart Card with a PLUS Smart Card.

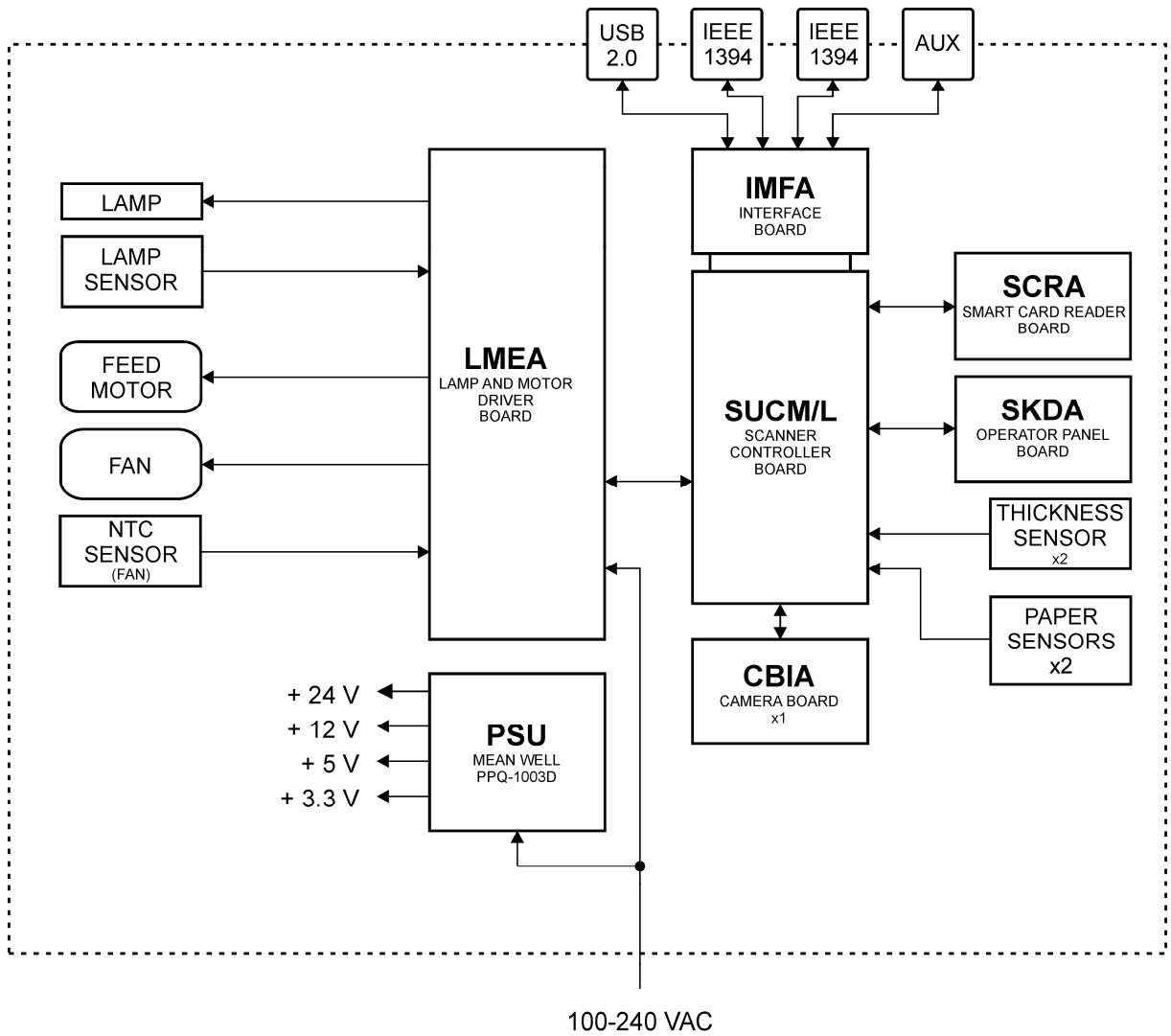

Fig. 2-1 COUGAR Sx 25 and CHAMELEON Sx 25 Block Diagram

2.2 CHROMA XL 42 and CRYSTAL XL 42

The Block Diagram is shown in:

Fig. 2-2 CHROMA XL 42 and CRYSTAL XL 42 Block Diagram, page 9

The CHROMA XL 42 and CRYSTAL XL 42 scanner range consists of:

Model:	GN67D		GP67D	
Trade name:	CHROMA XL 42	CHROMA XL 42 PLUS	CRYSTAL XL 42	CRYSTAL XL 42 PLUS
No. of cameras:	3	3	3	3
CCD	4x 7500	4x 7500	4x 7500	4x 7500
Chassis:	42 inches	42 inches	42 inches	42 inches
Scan width:	42 inches	42 inches	42 inches	42 inches
Computer interface:	USB/IEEE 1394	USB/IEEE 1394	USB/IEEE 1394	USB/IEEE 1394
Scan mode:	Color Monochrome	Color Monochrome	Color Monochrome	Color Monochrome
Optical resolution:	508 dpi	508 dpi	508 dpi	508 dpi
SmartCard:	BASIC	PLUS	BASIC	PLUS

Each of the two models GN67D and GP67D are marketed with two different levels of functionality, such as image resolution, scanning speed, scanning modes, etc:

Model: GN67D (USB and IEEE 1394 interface)
 Trade names: CHROMA XL 42 (basic level of functionality)
 CHROMA XL 42 PLUS (enhanced level of functionality)

Model: GP67D (USB and IEEE 1394 interface)
 Trade names: CRYSTAL XL 42 (basic level of functionality)
 CRYSTAL XL 42 PLUS (enhanced level of functionality)

The basic versions of the scanners (CHROMA XL 42 and CRYSTAL XL 42) may be field upgraded to the enhanced versions (CHROMA XL 42 PLUS and CRYSTAL XL 42 PLUS) by replacing the BASIC Smart Card with a PLUS Smart Card.

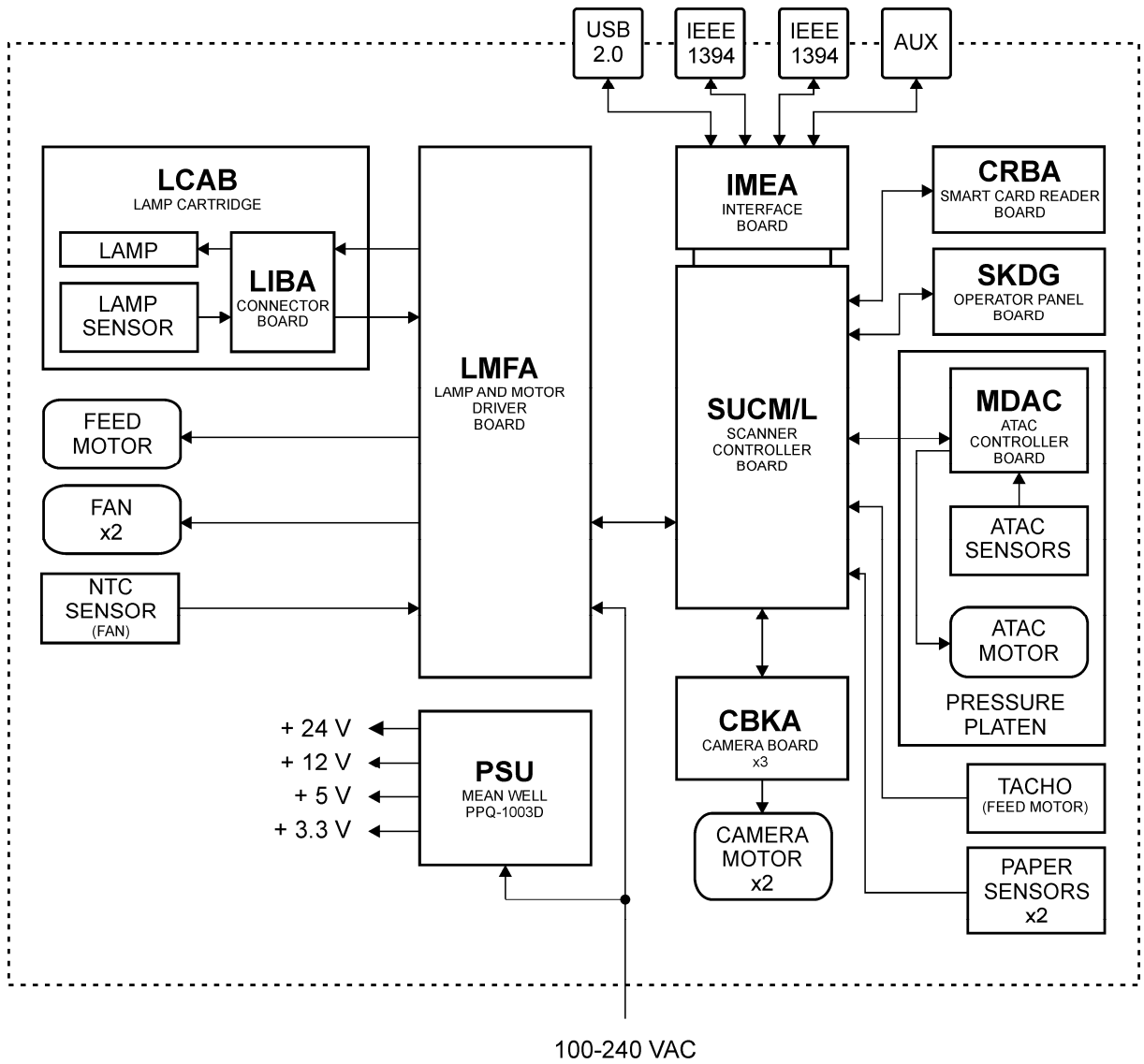

Fig. 2-2 CHROMA XL 42 and CRYSTAL XL 42 Block Diagram

3. Electrical Tests and Adjustments

Required Test Equipment:

Multimeter, $R_i > 10 \text{ MOhm}$

PC with:

- SCANtest 6* installed
- Scanner Maintenance* installed
- USB interface
- IEEE 1394 interface

*SCANtest 6 and Scanner Maintenance are described in FSG/MTM/001 (found in FSG/TSM/001).

3.1 LMF (used in XL 42 scanners)

All test points referred to below are shown in Fig. 3-1, page 12.

All DC voltages are measured relative to test point GND.

CAUTION:

Connectors J1, J7 and all the components in the hatched area are connected to the line voltage and constitute a risk of electric shock, or injury to persons.

3.1.1 DC Voltages

Ref. on Fig. 3-1	DC Voltage
Test point GND	GND
TP8 - GND	+3.3 V \pm 0.1 V
TP9 - GND	+5.3 V +0/-0.2 V
TP10 - GND	+12.0 V + 1/-0 V
TP18 - GND	+24.0 V \pm 1 V
TP16 - GND	+5.0 V \pm 0.15 V
TP15 - GND	+12.0 V \pm 0.3 V
TP5 – TP7 *	+200 V \pm 20 V
TP7 – TP6*	-200 V \pm 20 V

* Caution: These test points are at high voltage level and constitute a risk of electric shock, or injury to persons.

3.1.2 Lamp Driver

The LMF board is designed to work with calibrated Lamp Cartridges which means that there is no adjustment of the lamp driver.

3.1.3 Stepper Motor Driver

There are no adjustments to the Stepper Motor Driver on the LMF board

3.1.4 The LMF board is designed to work with calibrated Lamp Cartridges which means that there Functional Test

SCANtest 6: Test 5, Lamp Test

Test 6, Motor Test

3.1.5 Fuses

The type and rating of the fuse on the LMFA-Board is:

F1: T2.0AH/250V, type IEC 127- 2/5, UL R/C

CAUTION:

For continued protection against risk of fire, replace only with same type and rating of fuse.

3.1.6 Markings

CHROMA XL 42	LMFAdd
CRYSTAL XL 42	LMFAdd
where dd = board revision number.	

3.1.7 Jumper Settings

Jumper:	JP1
	not installed

3.1.8 Hints

Jumper on JP1: Not installed: Lamp controlled by SUC
 Installed: Lamp constant ON

Control signals on J11:

pin 2: Lamp ON/OFF, LOW = ON
 pin 8: Feed-Motor Step Pulse
 pin 11: Feed-Motor Direction, LOW = FORWARD

Fan Speed Control:

A NTC Temperature Sensor located under the End Cover at the Operator Panel end of the scanner controls the speed of the fans connected to J13 and J14.

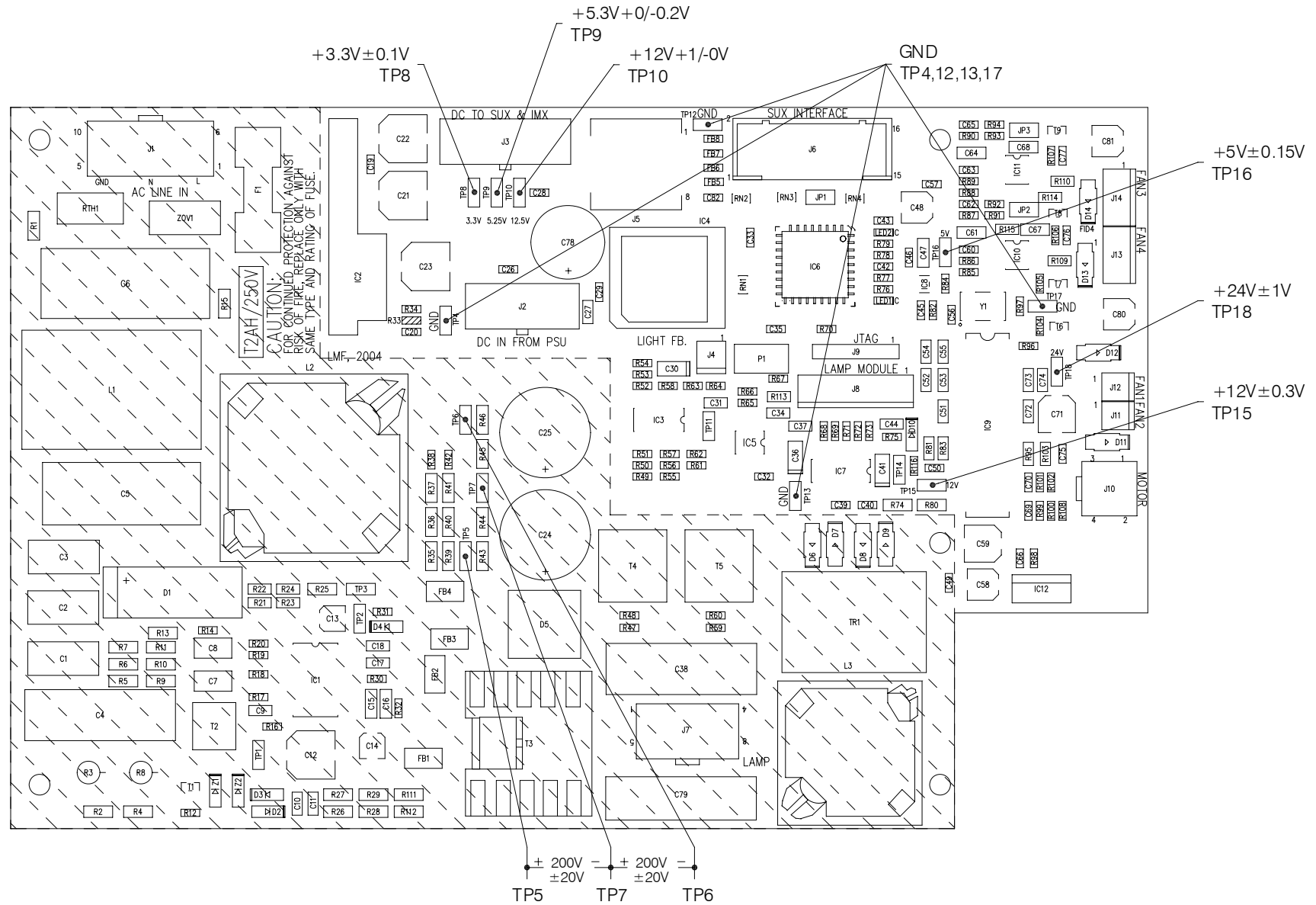

Fig. 3-1 LMF Component Layout

3.2 CBI (used in Sx 25 scanners)

All test points referred to are shown in Fig. 3-2, page 14.

All voltages are measured relative to test point GND.

3.2.1 DC Voltages

Ref. on Fig. 3-2	DC Voltage	Remarks
D3, bottom	+5.3 V \pm 0/-0.2 V	From SUC / SMPS
D3, top	+5.0 V \pm 0.2 V	Derived from +5.3V
D2, top	+5.0 V \pm 0.2 V	Derived from +5.3V
D4, bottom	+12.0 V \pm 1/-0 V	From SUC / SMPS, used for CCD and Camera Motor
D4, top	+11.6 V \pm 0.6 V	Derived from +12V
C301, bottom	+3.3 V \pm 0.1 V	From SUC / SMPS
D308, bottom	+1.8 V \pm 0.1 V	Derived from +3.3V

3.2.2 Adjustments

The gain and offset of the CBI-Board are adjusted automatically by running Scanner Maintenance.

3.2.3 Functional Test

SCANtest 6: Test 7, Complete Hardware Test

3.2.4 Markings

COUGAR Sx 25	CBIAdd
CHAMELEON Sx 25	CBIAdd
where dd = board revision number.	

3.2.5 Jumper Settings

No jumpers.

3.2.6 Hints

+3.3 V, +5.3 V, and +12 V is supplied from the SMPS via the SUC-Board.

CCD

The lines of pixels on the CCD are covered by color filters and arranged as follows:

Upper line on the CCD:	Blue
Center line on the CCD:	Green
Lower line on the CCD:	Red

As the image is mirrored an even number of times (mirror chassis and lens), the Blue line remains upper line when referred to the original.

Control of Camera Motor

The Camera Motor for Vertical Alignment is driven from a controller IC on the CBI-Board. The supply voltage for the motor is +12 V.

The motor can be tested using test 9, Camera Adjustment (Forward / Reverse controls for the Camera Motor)

After replacement of CBI-Board, do:

- CCD-Centering, see FSG/MTM/001.
- Vertical Positioning, see FSG/MTM/001.
- Check Scan-Width, if it is within the limits given in FSG/MTM/001, Focus will also be OK, and no further adjustments are required.
- Run Scanner Maintenance, see FSG/MTM/001.

These adjustments can be made without loosening the Camera Fixing Screws and without loosening the Focus Lock Ring / Lock Screw.

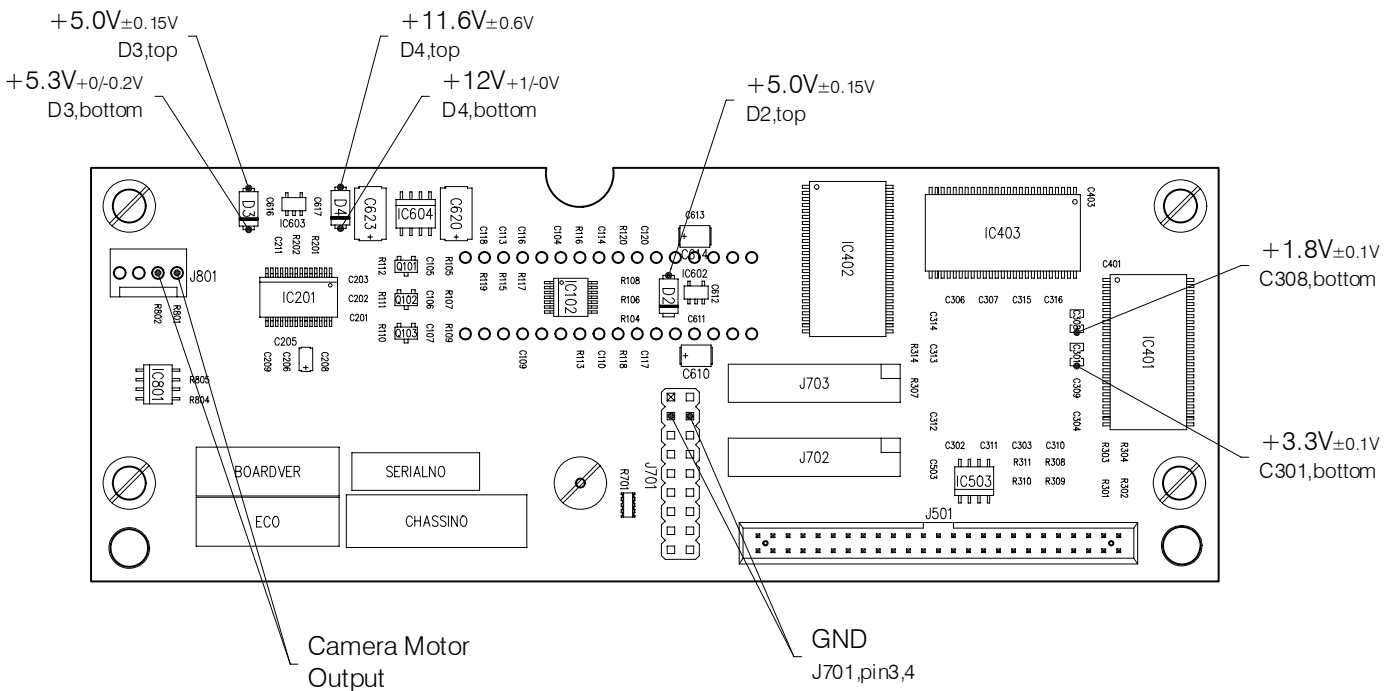

Fig. 3-2 CBI Component Layout

3.3 CBK (used with XL 42 scanners)

All test points referred to are shown in Fig. 3-3, page 16.

All voltages are measured relative to test point GND.

3.3.1 DC Voltages

Ref. on Fig. 3-3	DC Voltage	Remarks
D3, bottom	+5.3 V \pm 0/-0.2 V	From SUC / SMPS
D3, top	+5.0 V \pm 0.2 V	Derived from +5.3V
D2, top	+5.0 V \pm 0.2 V	Derived from +5.3V
D4, bottom	+12.0 V \pm 1/-0 V	From SUC / SMPS, used for CCD and Camera Motor
D4, top	+11.6 V \pm 0.6 V	Derived from +12V
C301, bottom	+3.3 V \pm 0.1 V	From SUC / LMF
D308, bottom	+1.8 V \pm 0.1 V	Derived from +3.3V

3.3.2 Adjustments

The gain and offset of the CBK-Board are adjusted automatically by running Scanner Maintenance.

3.3.3 Functional Test

SCANtest 6: Test 7, Complete Hardware Test

3.3.4 Markings

CHROMA XL 42	CBKAdd
CRYSTAL XL 42	CBKAdd
where dd = board revision number.	

3.3.5 Jumper Settings

No jumpers.

3.3.6 Hints

+3.3 V is supplied from the LMF via the SUC-Board.

+5.3 V and +12 V is supplied from the SMPS via the SUC-Board.

CCD

The lines of pixels on the CCD are arranged as follows:

Upper line on the CCD:	Red
2nd line on the CCD:	Green
3rd line on the CCD:	Blue
Lower line on the CCD:	B/W

As the image is mirrored an even number of times (mirror chassis and lens), the Red line remains upper line when referred to the original.

3.4 SUCM and SUCL

These variants are covered by the description of the SUC boards in FSG/MTM/001. Board layout as for SUCH.

3.4.1 Markings

COUGAR Sx 25	SUCMdd
CHAMELEON Sx 25	SUCLdd
CHROMA XL 42	SUCMdd
CRYSTAL XL 42	SUCLdd
where dd = board revision number.	

3.4.2 Hint

In the Sx 25 scanners the +3.3V supply is supplied from the SMPS

In the XL 42 scanners the +3.3V supply is supplied from the LMF board

3.5 SKD

Please refer to the description in FSG/MTM/001

SKDG which is used in the XL 42 scanners is electrical identical to the SKDF variant (used in XL 54).

3.5.1 Markings

COUGAR Sx 25	SKDAdd
CHAMELEON Sx 25	SKDAdd
CHROMA XL 42	SKDGdd
CRYSTAL XL 42	SKDGdd
where dd = board revision number.	

3.5.2 Switch Setting (Scanner ID)

DIP Switch Setting:

	SW 1	SW 2	SW 3	SW 4	SW 5	SW 6	SW 7	SW 8	HE X
COUGAR Sx 25	OFF	OFF	ON	OFF	ON	OFF	OFF	OFF	0x28
CHAMELEON Sx 25	OFF	OFF	ON	ON	OFF	OFF	ON	OFF	0x32
CHROMA XL 42	OFF	OFF	ON	ON	OFF	OFF	OFF	OFF	0x30
CRYSTAL XL 42	OFF	OFF	ON	ON	OFF	OFF	ON	ON	0x33

An undefined switch setting may cause the 'Invalid Scanner ID' Error Code to be displayed on the Operator Panel.

CAUTION:

The Scanner ID Switch setting is stored in the Flash Memory on the SUC-Board. Every time the scanner is switched ON, it reads the switch setting and if it is different from the stored value, the new setting will be stored and all other stored scanner parameters (including Stitching, Basic Calibration and Color Calibration) will be cleared to default values.

This means that the scanner must be calibrated using Scanner Maintenance afterwards to restore the actual values.

3.6 IME (used in XL 42 scanners)

All test points referred to below are shown in Fig. 3-4, page 19.

All voltages are measured relative to test points GND_T1.

3.6.1 DC Voltages

Ref. on Fig. 3-4	DC Voltage
R34, top	+5.3 V +0/-0.2 V
+5V0_D1	+5.2 V +0/-0.2 V
+3V3_D1	+3.3 V \pm 0.1 V

3.6.2 Adjustments

No adjustments.

3.6.3 Functional Test

Connect the computer to each separate port in turn and start SCANtest 6 or WIDEsystem to check if the scanner is connecting on all ports available.

3.6.4 Markings

CHROMA XL 42	IMEAdd
CRYSTAL XL 42	IMEAdd
where dd = board revision number.	

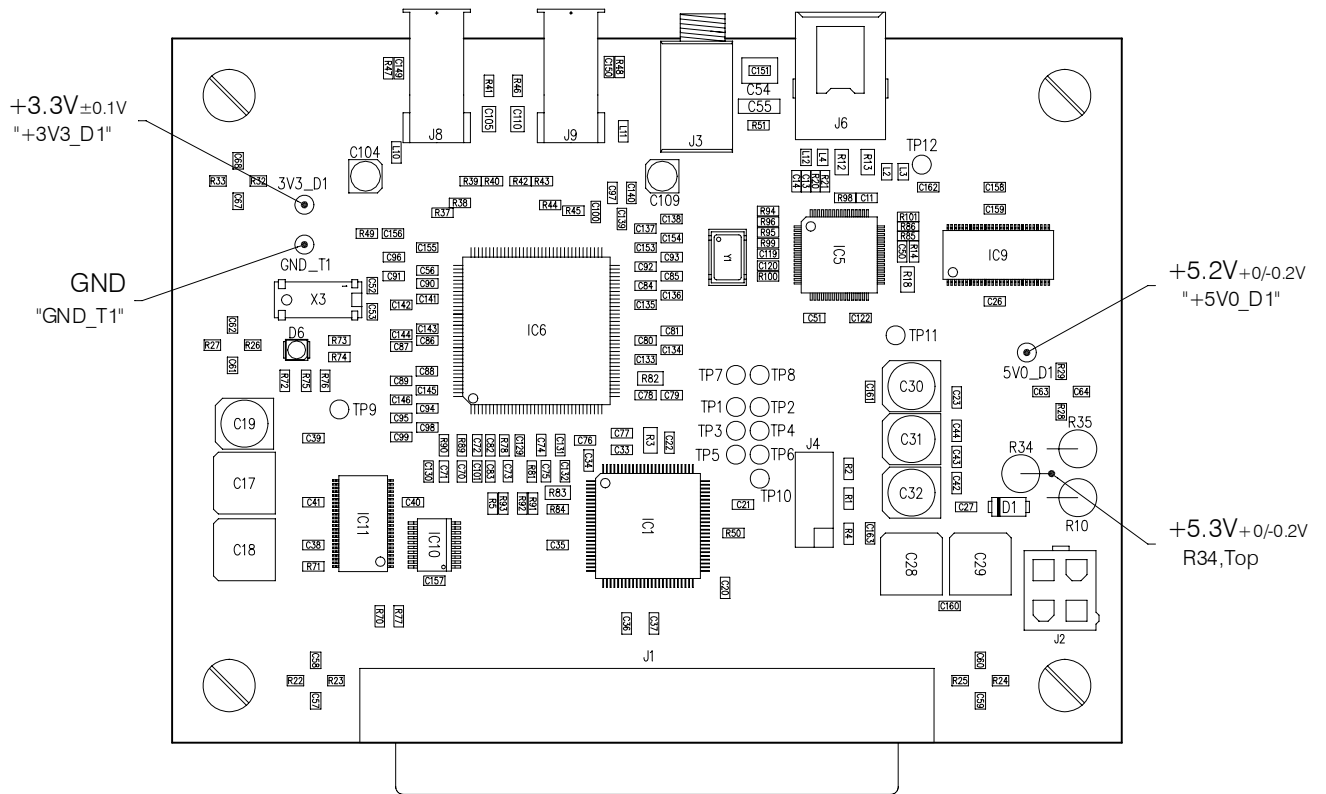

Fig. 3-4 IME Component Layout

3.7 IMF (used in Sx 25 scanners)

All test points referred to below are shown in Fig. 3-5, page 21.

All voltages are measured relative to test points GND_T1.

3.7.1 DC Voltages

Ref. on Fig. 3-5	DC Voltage
R34, top	+5.3 V +0/-0.2 V
+5V0_D1	+5.2 V +0/-0.2 V
+3V3_D1	+3.3 V \pm 0.1 V

3.7.2 Adjustments

No adjustments.

3.7.3 Functional Test

Connect the computer to each separate port in turn and start SCANtest 6 or WIDESystem to check if the scanner is connecting on all ports available.

3.7.4 Markings

COUGAR Sx 25	IMFAdd
CHAMELEON Sx 25	IMFAdd
where dd = board revision number.	

3.8 CRB (used in XL 42 scanners)

All test points referred to below are shown in Fig. 3-6, page 24

All DC voltages are measured relative to test point GND

3.8.1 DC Voltages

Ref. on Fig. 3-6	DC Voltage	Remarks
VR1, pin3	+5.3 V +0/-0.2 V	From SUC / LMF
VR1, tap	+3.3 V \pm 0.1V	Derived from +5.3V

3.8.2 Functional Test

SCANtest 6: Test 1, Scanner Model (Smart Card)

3.8.3 Markings

CHROMA XL 42	CRBAdd
CRYSTAL XL 42	CRBAdd
where dd = board revision number.	

3.8.4 DIP Switch Setting

SCSI related switch settings (SW No. 1, 2, 3, 4, and 5) do not apply for the XL 42 scanners but should be set to the default settings shown in the table below.

Default DIP Switch Setting:

Switch No:	1	2	3	4	5	6	7	8
SCSI ID 2	ON	OFF	ON	ON	OFF	OFF	OFF	OFF

SCSI ID, Terminator, and Communication Mode Selection:

Switch No:	1	2	3	4	5	6	7	8
SCSI ID 0	ON	ON	ON	X	X	X	X	X
SCSI ID 1	OFF	ON	ON	X	X	X	X	X
SCSI ID 2	ON	OFF	ON	X	X	X	X	X
SCSI ID 3	OFF	OFF	ON	X	X	X	X	X
SCSI ID 4	ON	ON	OFF	X	X	X	X	X
SCSI ID 5	OFF	ON	OFF	X	X	X	X	X
SCSI ID 6	ON	OFF	OFF	X	X	X	X	X
SCSI ID 7	OFF	OFF	OFF	X	X	X	X	X
<i>SCAN-SCSI Termination</i>								
Intern, active:				ON				
Extern:				OFF				
<i>SCAN-SCSI Transfer mode</i>								
Asynchronous:					ON			
Synchronous:					OFF			
<i>Not used</i> (Don't care)						(OFF)		

Troubleshooting and Test Switches:

Switch No:	1	2	3	4	5	6	7	8
<i>Boot start-up</i>								
Forced:							ON	
Normal:							OFF	
<i>Factory testing</i>								
Self-test:								ON
Normal:								OFF

- SW1-3: SCSI ID
- SW4: Selects internal, active SCSI termination or external, passive SCSI termination, normally set to ON.
- SW5: If the SCSI communication fails try to run 'Asynchronous'. This mode is intended for debugging, and SW5 should normally be set to OFF.
- SW6: Not used.
- SW7: If download fails, try to set SW7 to ON. For normal operation SW7 must be set to OFF.
- SW8: Reserved for factory testing and **must** be set to OFF.

NB! The switches are read at power-on only, and the scanner must be switched OFF and back ON for a changed switch setting to become effective.

3.8.5 Signal LED on the CRB Board

The signal LED (LED1) on the CRB Board turns ON when a Smart Card is inserted. It only signals, that a Smart Card has been inserted, it does not show whether the card is valid or not.

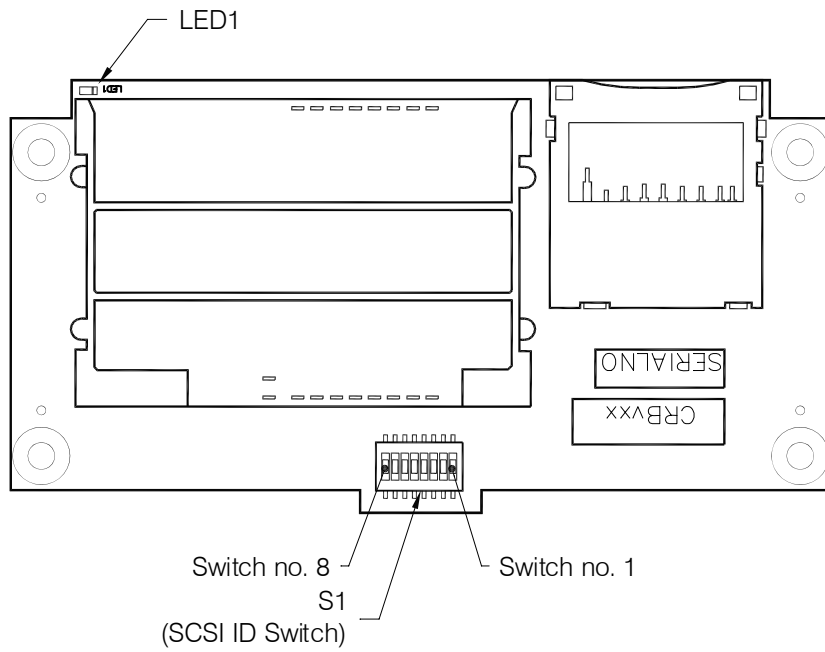
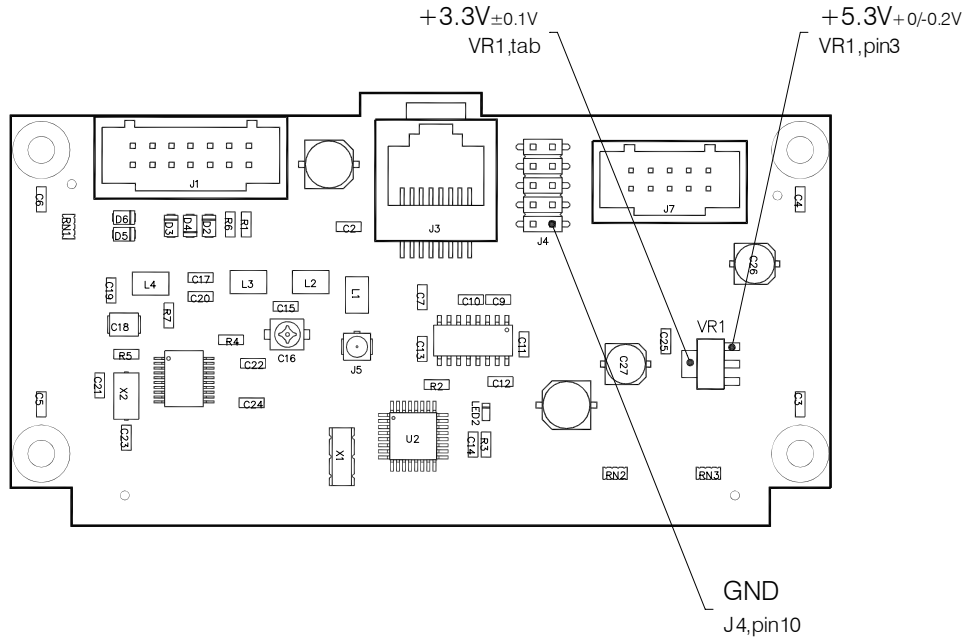

Fig. 3-6 CRB Component Layout

3.9 MDA (used in XL 42 scanners)

All test points referred to below are shown in Fig. 3-7, page 24.
 All voltages are measured relative to test points TP1 (GND).

3.9.1 DC Voltages

Ref. on Fig. 3-7	DC Voltage	Remarks
C2, left	+12.0 V +1/-0 V	SUC, 12V_CAM
C4, top	+5.3 V +0/-0.2 V	SUC, 5V_CAM
TP2	+5.0 V ± 0.15 V	Regulator on MDA
TP4	+3.3 V ± 0.1 V	Regulator on MDA

3.9.2 Functional Test

SCANtest 6, Test 28, Original Sensor Test
 See FSG/MTM/001

3.9.3 Markings

CHROMA XL 42	MDACdd
CRYSTAL XL 42	MDACdd
where dd = board revision number.	

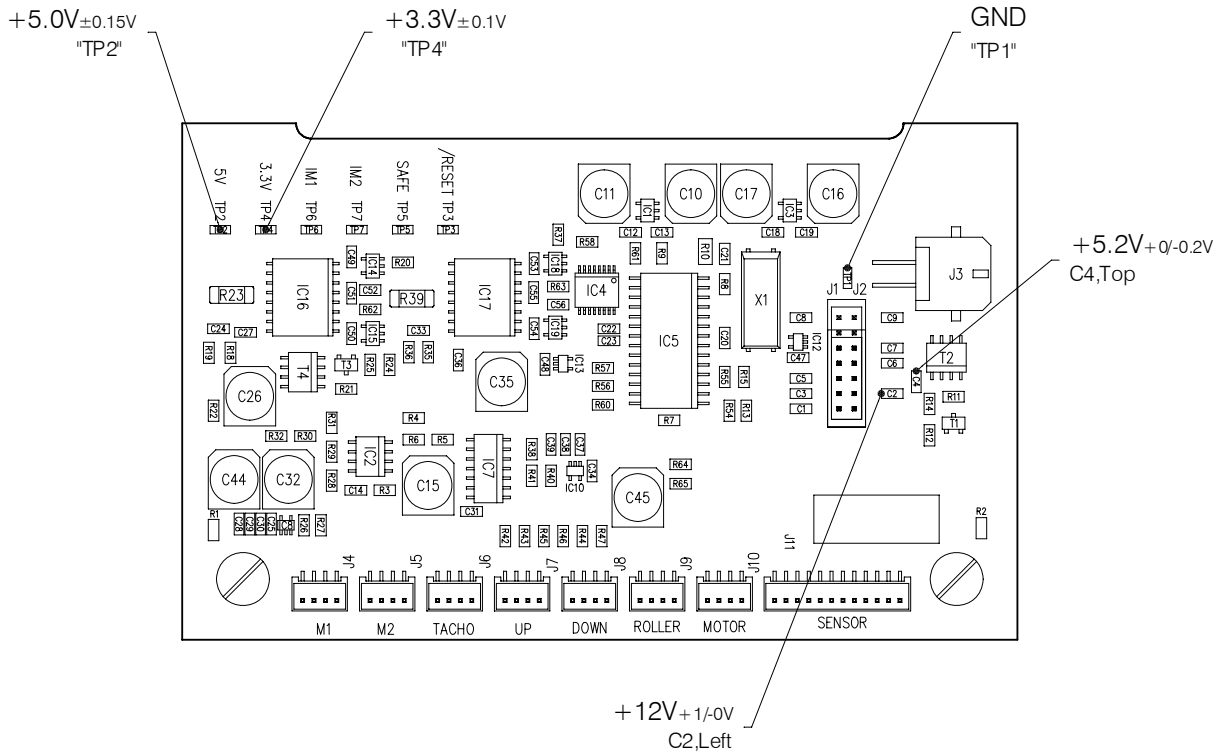

Fig. 3-7 MDA Component Layout

3.10 LCA (used in XL 42 scanners)

In the XL 42 scanners the lamp has been replaced by a Lamp Cartridge which consists of a lamp and a light sensor.

Each Lamp Cartridge is factory calibrated which means that the Lamp Cartridge can be replaced without the need for adjustment.

IMPORTANT: Do not try to disassemble the Lamp Cartridge in order to replace the lamp. This will ruin the calibration resulting in either reduced scanning quality or reduced lamp life.

Attempting to replace the lamp tube will violate safety and constitute a risk of electric shock, or injury to person

3.11 Check and Adjustment of Original Guide Sensors (ATAC) (XL 42 Only)

Please refer to FSG/MTM/001

3.12 Adjustment of Original Sensors

Sx 25 scanners: Please refer to FSG/MTM/001

XL 42 scanners: The Original Sensor comes complete with Mounting Bracket. Please replace the whole unit. No adjustment is needed.

4. CCD Camera

In the XL 42 scanners a new camera design has been used. The new camera differs mostly in the way the basic vertical position (camera tilt) is set/adjusted.

As on the old cameras the vertical position is adjusted by turning the Vertical Adjustment Screw (located under the camera housing) which tilts the camera. But where the old cameras has a “finger wheel” fixed to the screw, the screw on the new cameras must be turned using a special spanner. As it can be seen in Fig. 4-1 page 28 the spanner is the one end of the upper half of the Vertical Alignment Arm.

Even when the Vertical Alignment Arm is not fixed to the Vertical Adjustment Screw the camera tilt will change slightly when turning the Vertical Alignment Arm. Because of this the Vertical Alignment Arm has to be installed and set to its initial position when adjusting the vertical position of the camera. As this rules out using the upper half of the Vertical Alignment Arm of the camera which is adjusted, this part is attached to the spindle console of the fixed camera (camera B). The sole purpose of this part is to be used when adjusting the camera tilt.

Normally there is no need to change the factory set basic vertical position of the cameras nor to change the position of the Vertical Alignment Arm. But if it happens that the Vertical Alignment Arm is close to one of the outer positions and needs to be returned to its initial position or if a camera needs to be tilted, proceed as described below.

4.1 Setting the Initial Position of the Vertical Alignment Arm

Important: If the initial position of the Vertical Alignment Arm needs to be set this is most likely because the arm is not fixed properly to the Vertical Adjustment Screw or because the vertical position of the fixed camera has changed significantly. The vertical position of the cameras should therefore be checked/adjusted at the same time.

Refer to Fig. 4-1 page 28).

- Loosen the lock screw for the Vertical Alignment Arm (located under the camera housing opposite to the Vertical Alignment Arm)
- Loosen (and just loosen) the assembly screw for the Vertical Alignment Arm
- Push the lower half of the arm forward (1) until the assembly screw is free of the upper half of the arm and then swing the upper half upwards (2)
- Detach the upper half of the arm from the Spindle Nut (3) and let the lower part swing backwards
- Rotate the Spindle Nut to position it in the center of the motor spindle
- Attach the upper half of the Vertical Alignment Arm using the reverse order of the above description
- Tighten the assembly screw for the Vertical Alignment Arm
- Tighten the lock screw for the Vertical Alignment Arm

4.2 Adjusting the Camera Tilt

If the correct vertical position during camera adjustment can not be obtained by means of the tilt levers (see FSG/MTM/001 section 4.2.7) the camera tilt must be changed as described below.

Important: Before adjusting the camera tilt set the Vertical Alignment Arm to its initial position as described above.

- Loosen the lock screw for the Vertical Alignment Arm (located under the camera housing opposite to the Vertical Alignment Arm)

- On the fixed camera (camera B) locate the “upper half of the Vertical Alignment Arm” which is attached to the spindle console.
- Loosen the fixing screw and remove the arm. The end opposite to the spindle end is now used as a spanner for adjusting the Vertical Position.
- Set the Vertical Tilt Levers to their nominal positions, that is, horizontal position for the lever near the “connector end” of the camera board and vertical position for the other.
- Turn the Vertical Adjustment Screw using the “spanner” to get as total sum of 16 Black Lines (f.ex. 5 Black Lines at the start and 11 Black Lines at the end of the scanline).
- Tighten the lock screw for the Vertical Alignment Arm and proceed with tyhe camera adjustment as described in FSG/MTM/001)

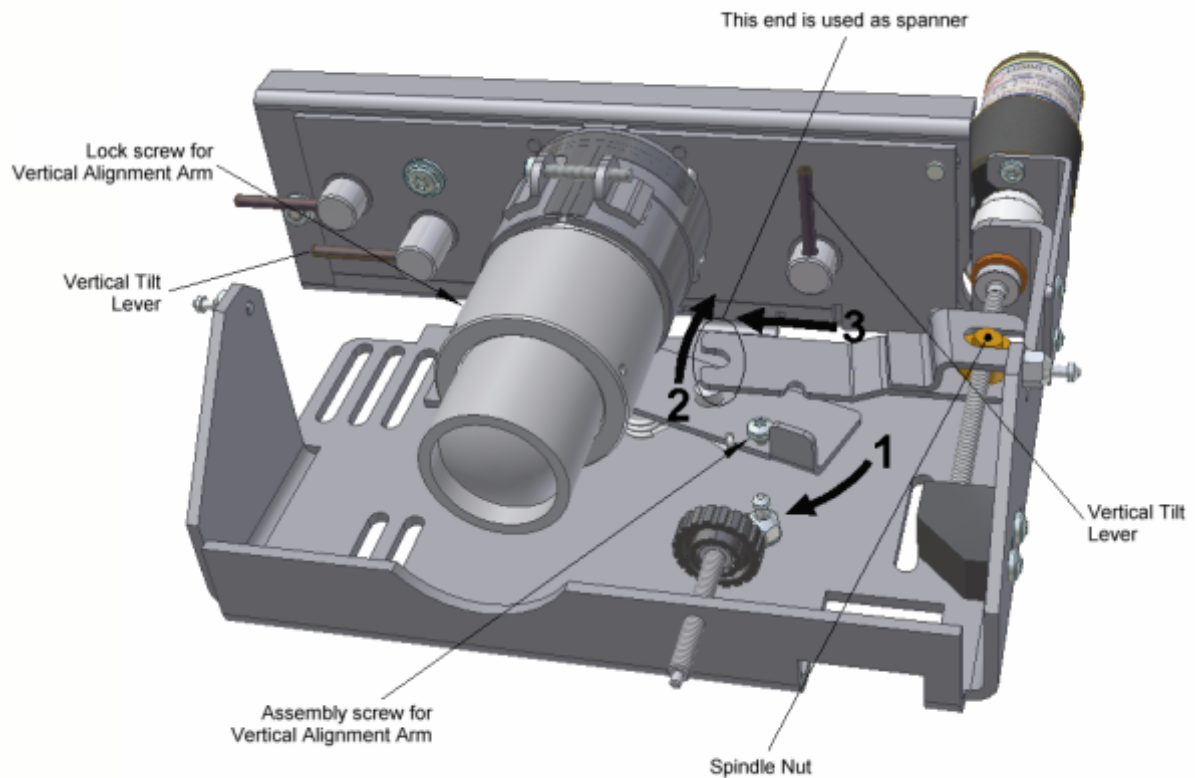

Fig. 4-1 CCD Camera

4.3 CCD-Camera Check and Adjustment

To get access to the CCD Cameras the Top Cover must be removed.

Equipment needed:

- PC with SCANtest 6 and Scanner Maintenance installed:

COUGAR Sx 25, CHAMELEON Sx 25,
CHROMA XL 42, CRYSTAL XL 42: USB or IEEE 1394

- Optical Adjustment Pattern:

COUGAR Sx 25, CHAMELEON Sx 25: 6779D105*
CHROMA XL 42, CRYSTAL XL 42: 6779D134

- Focus Pattern:

COUGAR Sx 25, CHAMELEON Sx 25: 6779D215*
CHROMA XL 42, CRYSTAL XL 42: 6779D216*

* Refer to FSG/MTM/001

4.3.1 Check of Light Profiles

The uncorrected and corrected light profiles are shown for reference below.

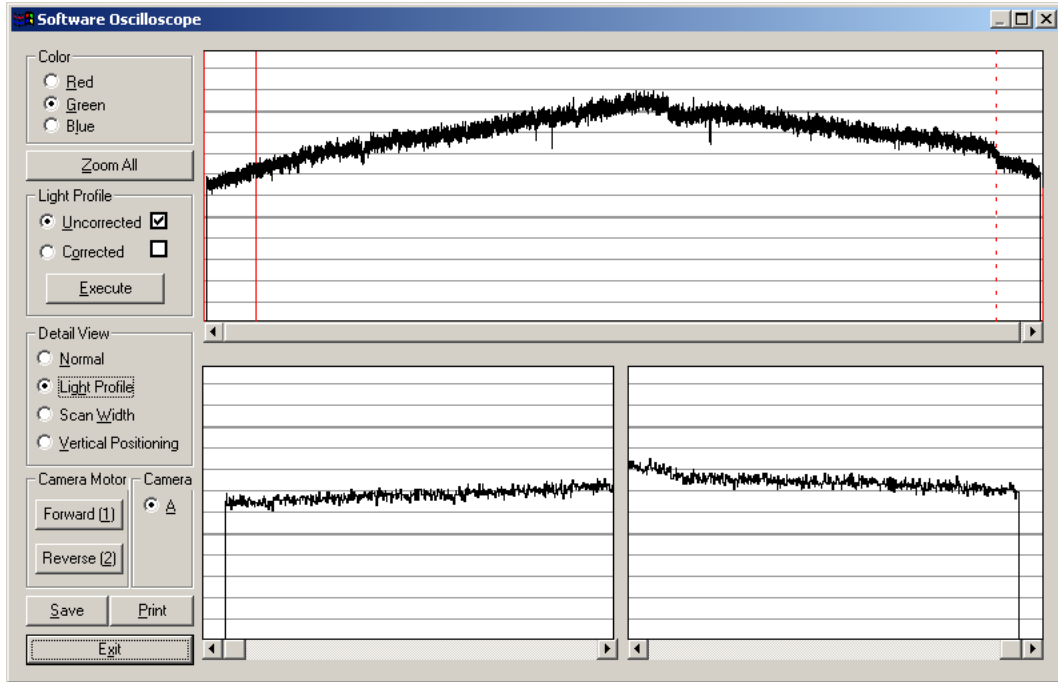

Fig. 4-2 Sx 25 Uncorrected Light Profile

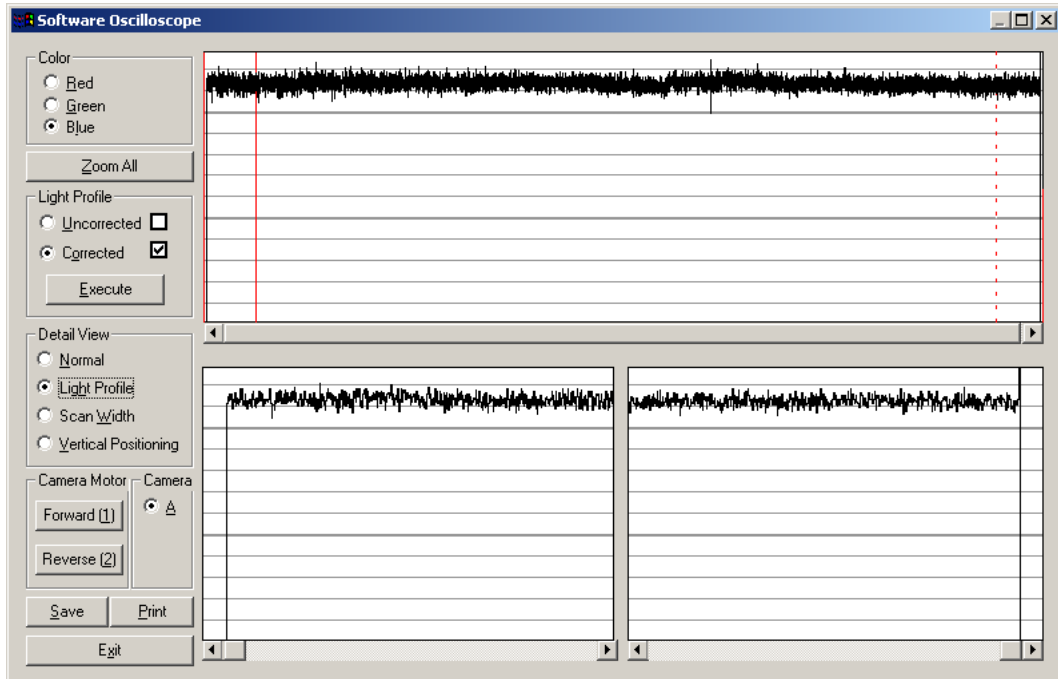

Fig. 4-3 Sx 25 Corrected Light Profile

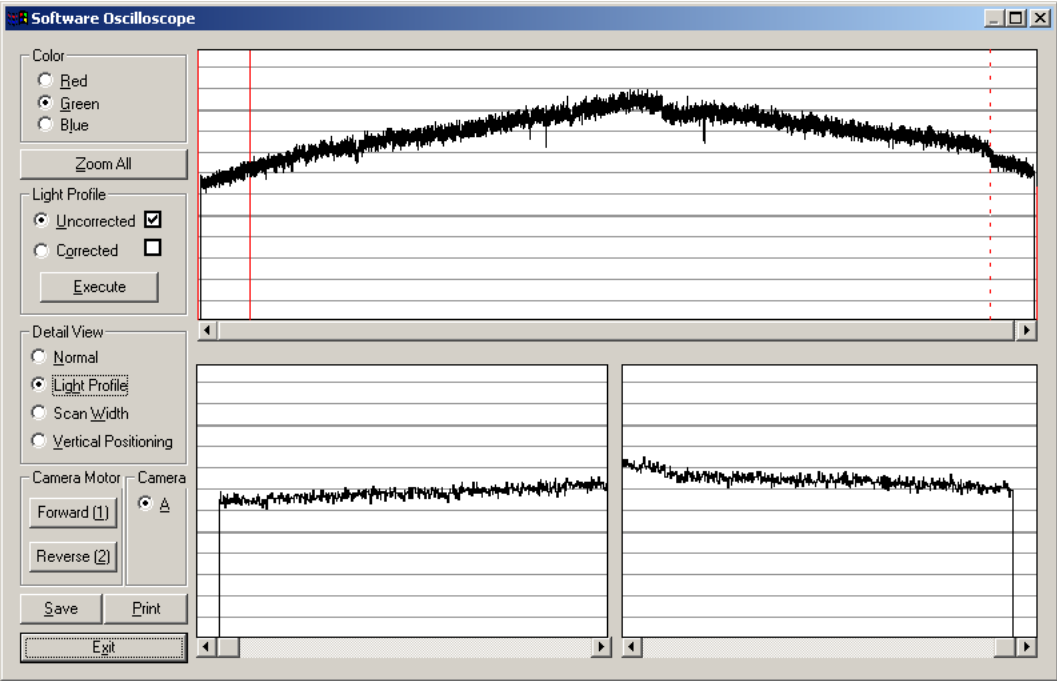

Fig. 4-4 XL 42 Uncorrected Light Profile

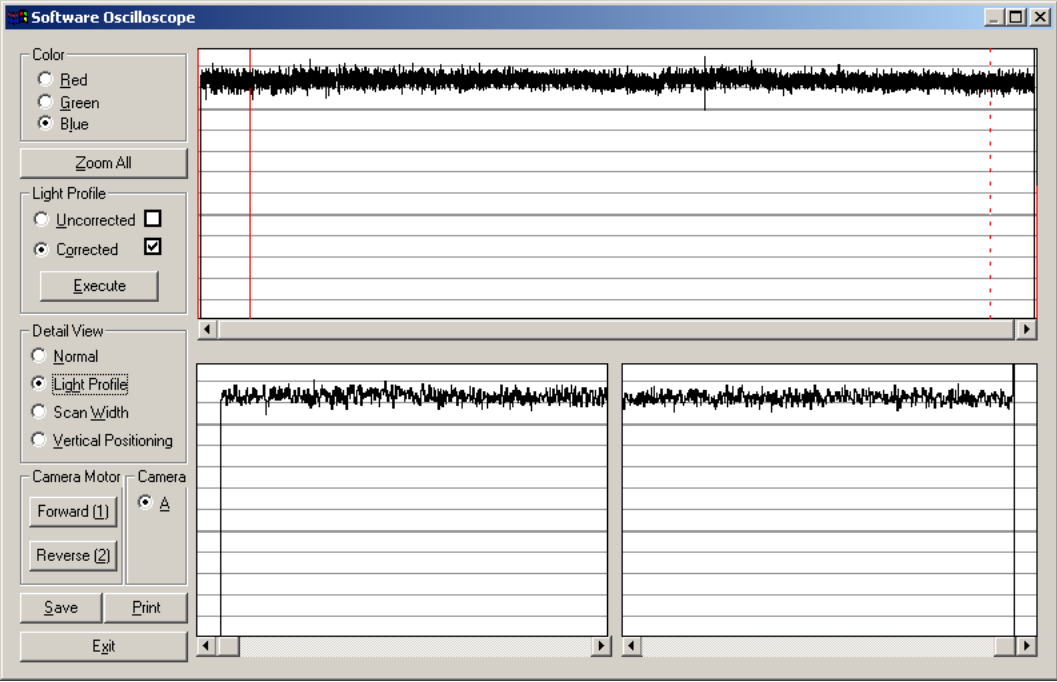

Fig. 4-5 XL 42 Corrected Light Profile

4.3.2 Check and Adjustment of Focus

IMPORTANT: The focus adjustment is factory optimized for all three colors (Red, Green and Blue) which may cause that the focus signal for Blue is not as even as it could be. This is especially important on multi camera scanners in order to avoid visible camera transitions.

Only change the focus adjustment if it is absolutely necessary, i.e. if the Scan-Width is not within the limits given in 4.3.3.

Refer to FSG/TSM/001 for adjustment procedure

IMPORTANT: After replacement of the Camera Board (CBx) check the Scan-Width. It is **ONLY** necessary to adjust the focus if the Scan-Width is not within the limits given in 4.3.3.

Important: On XL 42 scanners, be careful to center the focus pattern. If inserted shifted more than 10mm to either side, the pattern will not cover the full scan-width.

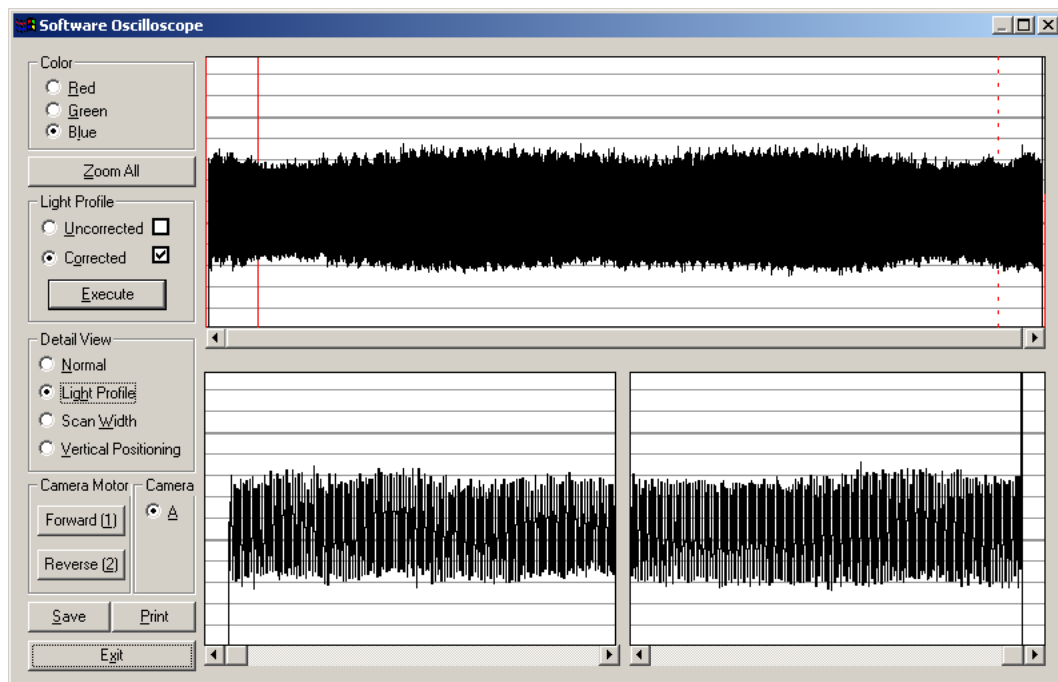

Fig. 4-6 Sx 25 Focus Signal (Blue Channel)

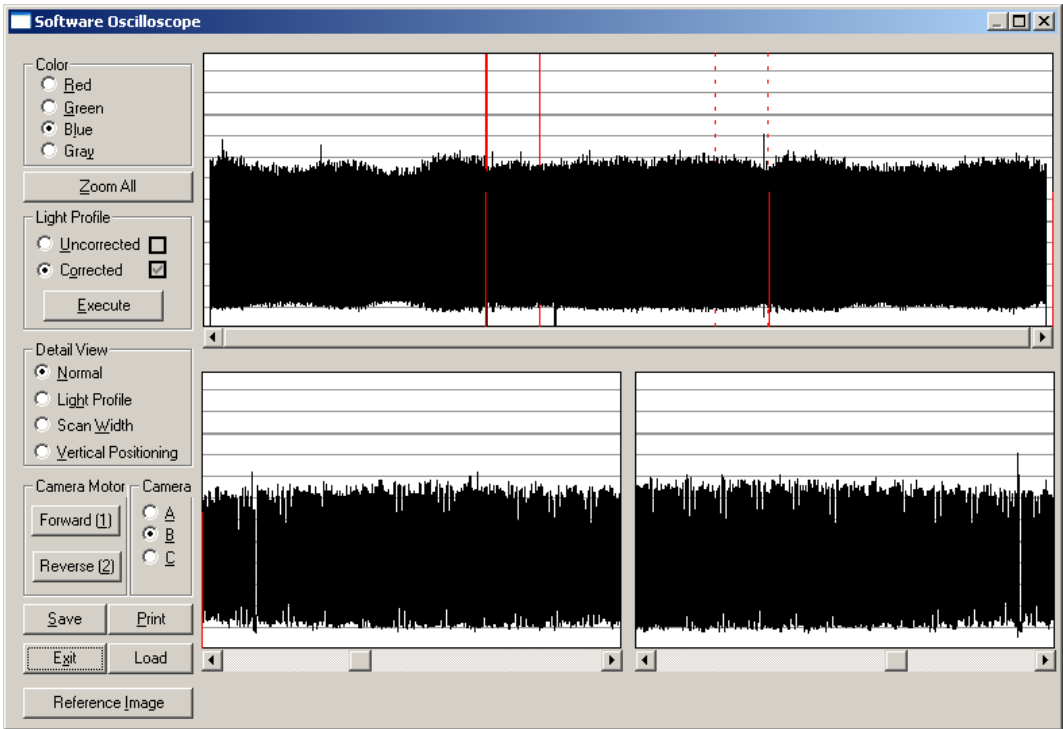

Fig. 4-7 XL 42 Focus Signal (Blue Channel)

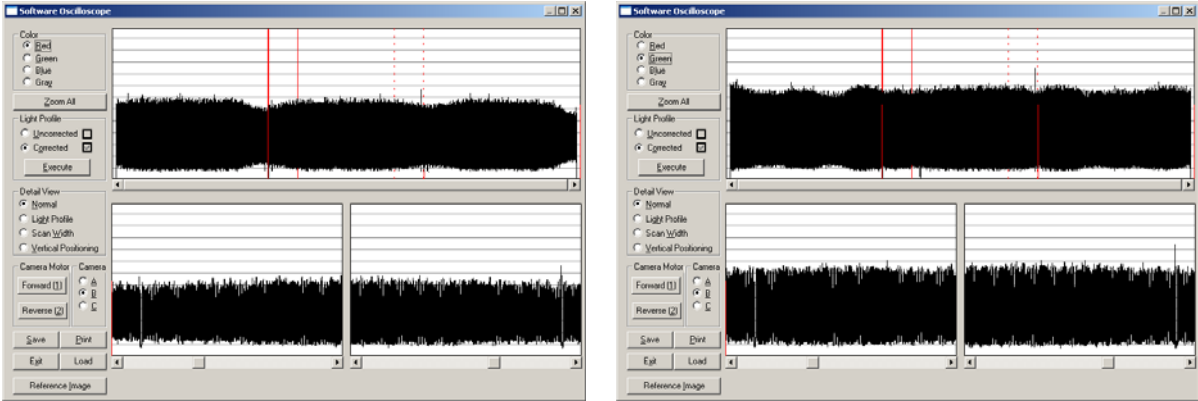

Fig. 4-8 XL 42 Focus Signal (Red and Green Channel)

Interaction

The Focus adjustment has a big influence on the Scan-Width adjustment. Therefore the Scan-Width must be checked and readjusted if necessary when the Focus adjustment has been changed. On the other hand, the Focus adjustment is relative tolerant to changes in the Scan-Width adjustment and as a rule of thumb, the Scan-Width adjustment can be changed ± 1 SWU without the need for re-focusing.

When all camera adjustments have been completed, run Scanner Maintenance.

4.3.3 Check and Adjustment of Scan-Width

Refer to FSG/TSM/001 for adjustment procedure

Images of the Scan-Width adjustments and the Optical Adjustments Patterns are shown in:

- Fig. 4-9 Sx 25, Scan-Width, CCD-Centering and Vertical Positioning
- Fig. 4-10 XL 42 Camera A: Scan-Width, CCD-Centering and Vertical Positioning
- Fig. 4-11 XL 42 Camera B: Scan-Width, CCD-Centering and Vertical Positioning
- Fig. 4-12 XL 42 Camera B: Scan-Width, CCD-Centering and Vertical Positioning
- Fig. 4-13 Optical Adjustment Pattern, 1 Camera, 25"
- Fig. 4-14 Optical Adjustment Pattern, 3 Camera, 42"

The aim of this adjustment is to obtain a *camera* Scan-Width of:

COUGAR Sx 25, CHAMELEON 25:	635 mm
CHROMA XL 42, CRYSTAL XL 42:	365.3/375.0/365.3 mm

The Scan-Width is correct if the total sum of Scan-Width Units (SWU) at the start and at the end of the scanline is as shown in the table below (*1 SWU is either 1 Black Line or 1 White Space of the Scan-Width Pattern (A)*).

Model	Optical Adjustment Pattern	Total sum of Scan-Width Units	Tolerance
COUGAR Sx 25 CHAMELEON Sx 25	6779D105, sub-pattern A	6	±0.5 SWU
CHROMA XL 42 CRYSTAL XL 42	6779D134, sub-pattern A	6	±0.5 SWU

The tolerance corresponds to approximately 0.10% on the Scan-Width (scaling error).

When all camera adjustments have been completed, run Scanner Maintenance.

4.3.4 Check and Adjustment of CCD-Centering

Refer to FSG/TSM/001 for adjustment procedure

Images of the Scan-Width adjustments and the Optical Adjustments Patterns are shown in:

Fig. 4-9 Sx 25, Scan-Width, CCD-Centering and Vertical Positioning

Fig. 4-10 XL 42 Camera A: Scan-Width, CCD-Centering and Vertical Positioning

Fig. 4-11 XL 42 Camera B: Scan-Width, CCD-Centering and Vertical Positioning

Fig. 4-12 XL 42 Camera B: Scan-Width, CCD-Centering and Vertical Positioning

Fig. 4-13 Optical Adjustment Pattern, 1 Camera, 25"

Fig. 4-14 Optical Adjustment Pattern, 3 Camera, 42"

The aim of this adjustment is to position the field of vision of the CCD-Camera symmetrically with respect to the Scan-Width Adjustment Patterns.

The Black Lines and White Spaces of the Scan-Width Patterns should be distributed symmetrically with the following number of Scan-Width Units at both ends of the scanline:

Model	Optical Adjustment Pattern	No of Scan-Width Units, start	No of Scan-Width Units, end	Tolerance
COUGAR Sx 25 CHAMELEON Sx 25	6779D105, sub-pattern A	3	3	± 1 SWU
CHROMA XL 42 CRYSTAL XL 42	6779D134, sub-pattern A	3	3	± 1 SWU

The tolerance on the CCD-Centering means that the image may be shifted ± 1 SWU.

Note: The total number of Scan Width Units must be 6 ± 0.5 , see Section 4.3.3, page 34.

Interaction

Check Vertical Position.

After completing all camera adjustments, run Scanner Maintenance.

4.3.5 Check and Adjustment of Vertical Positioning

Refer to FSG/TSM/001 for adjustment procedure

Images of the Scan-Width adjustments and the Optical Adjustments Patterns are shown in:

Fig. 4-9 Sx 25, Scan-Width, CCD-Centering and Vertical Positioning

Fig. 4-10 XL 42 Camera A: Scan-Width, CCD-Centering and Vertical Positioning

Fig. 4-11 XL 42 Camera B: Scan-Width, CCD-Centering and Vertical Positioning

Fig. 4-12 XL 42 Camera B: Scan-Width, CCD-Centering and Vertical Positioning

Fig. 4-13 Optical Adjustment Pattern, 1 Camera, 25”

Fig. 4-14 Optical Adjustment Pattern, 3 Camera, 42”

The aim of this adjustment is to place the scanline in the correct “Vertical Position” within the scan-area, and to ensure that the scanline is “horizontal”.

The Vertical Positioning of the CCD-Cameras is based on the number of black lines of the Vertical Position Pattern that crosses the scanline. The step height of the Black Lines in the Vertical Position Pattern is shown in the table following:

Model	Optical Adjustment Pattern	Step Height of Black Lines	Step Height 0 through 16 Black Lines
COUGAR Sx 25 CHAMELEON Sx 25	6779D105, sub-pattern B	0.15 mm	2.25 mm
CHROMA XL 42 CRYSTAL XL 42	6779D134, sub-pattern B	0.15 mm	2.25 mm

The cameras are adjusted to 8 Black Lines of the Vertical Position Pattern at both ends of the scanlines.

Interaction

After completing all camera adjustments, run Scanner Maintenance.

4.3.6 Final Check

As the above adjustments interact:

Check, and if necessary readjust steps 4.3.2 through 4.3.5

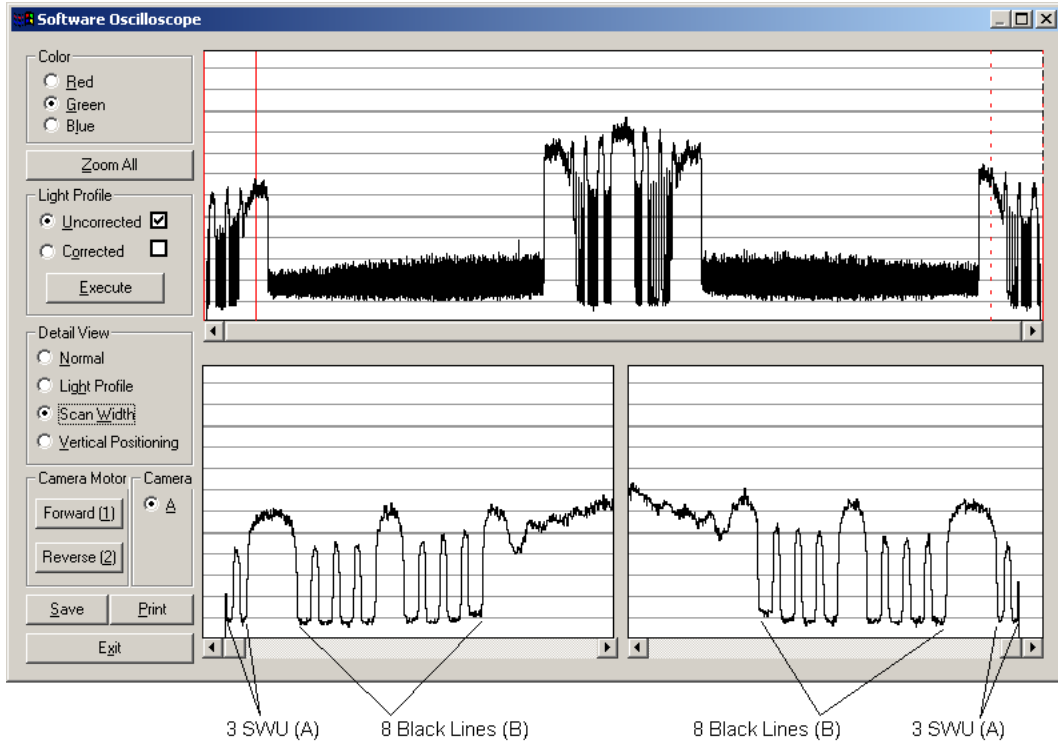

Fig. 4-9 Sx 25, Scan-Width, CCD-Centering and Vertical Positioning

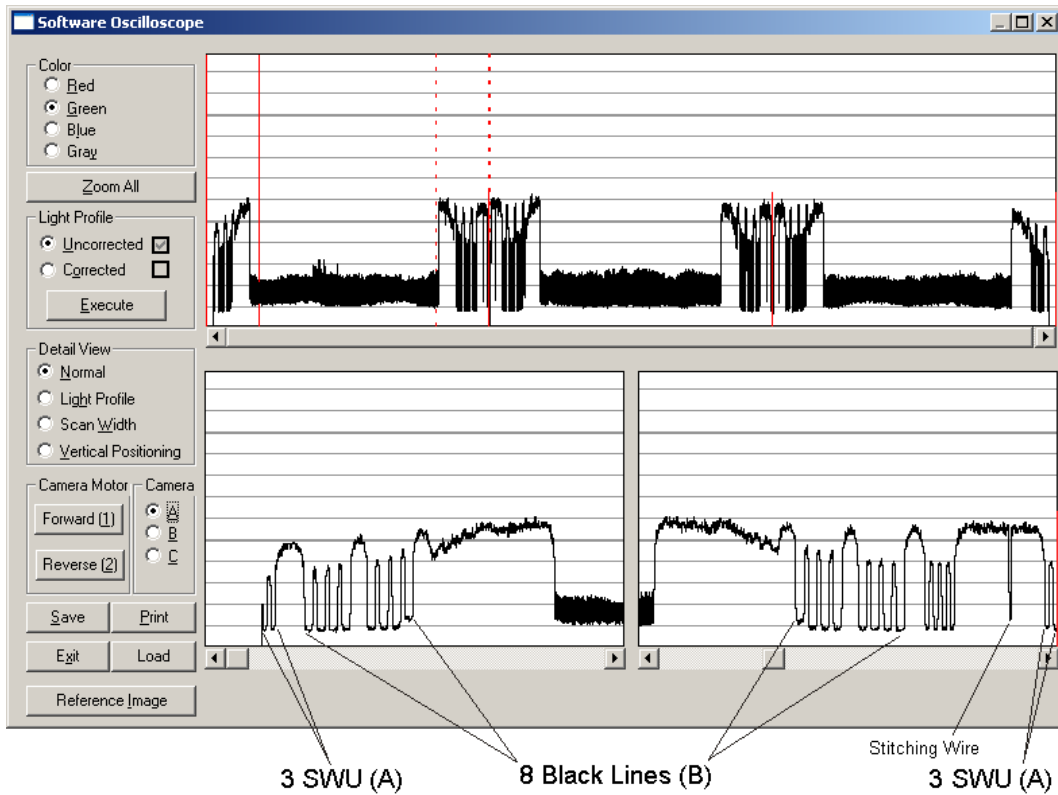

Fig. 4-10 XL 42 Camera A: Scan-Width, CCD-Centering and Vertical Positioning

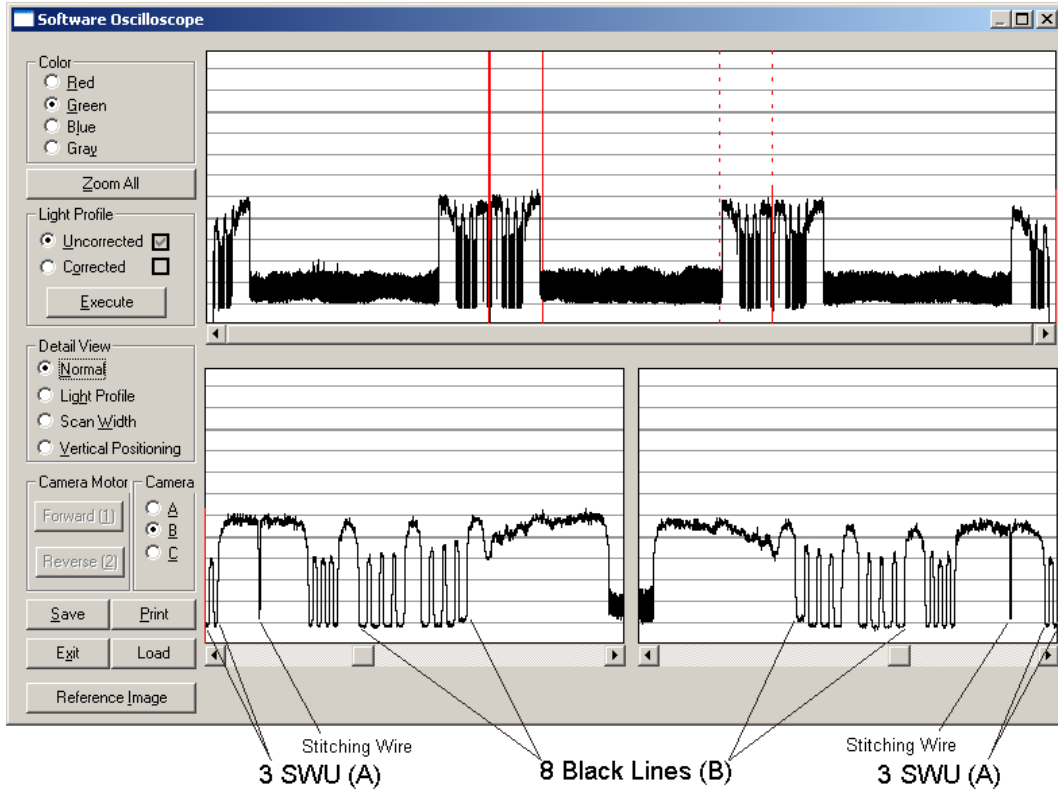

Fig. 4-11 XL 42 Camera B: Scan-Width, CCD-Centering and Vertical Positioning

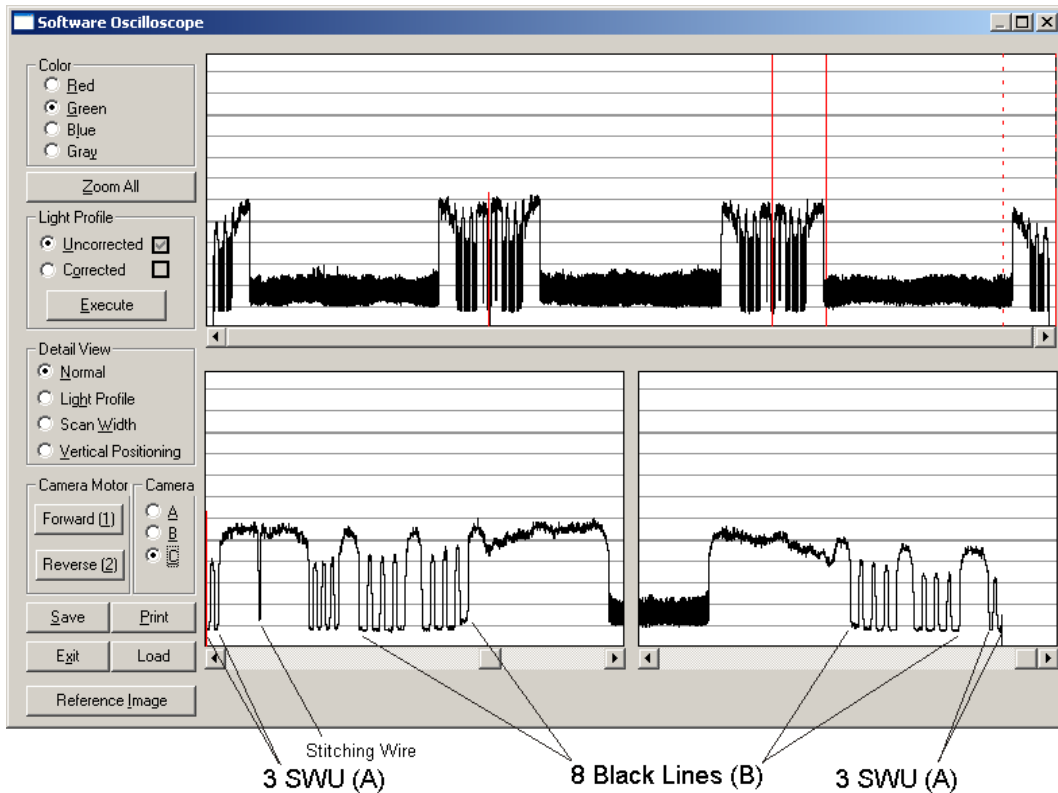
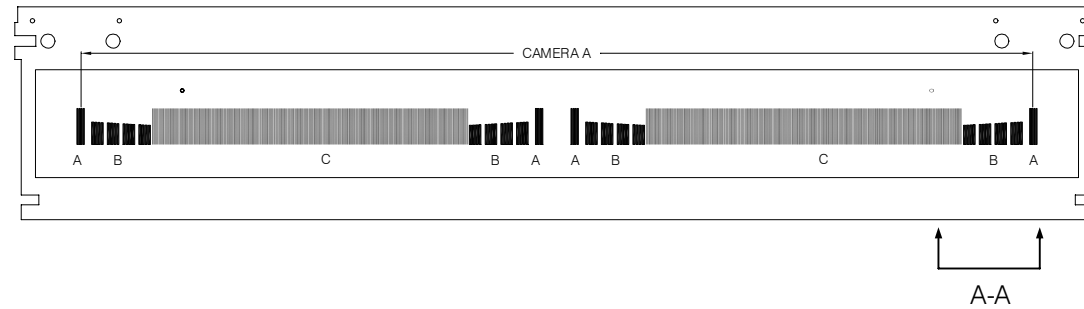
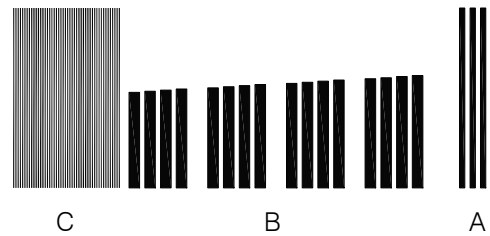

Fig. 4-12 XL 42 Camera B: Scan-Width, CCD-Centering and Vertical Positioning



- Sub-pattern A: Scan-Width Patterns
- Sub-pattern B: Vertical Position Patterns
- Sub-pattern C: Focus Pattern (used for coarse Focus adjustment)



Detail A-A

Fig. 4-13 Optical Adjustment Pattern, 1 Camera, 25"

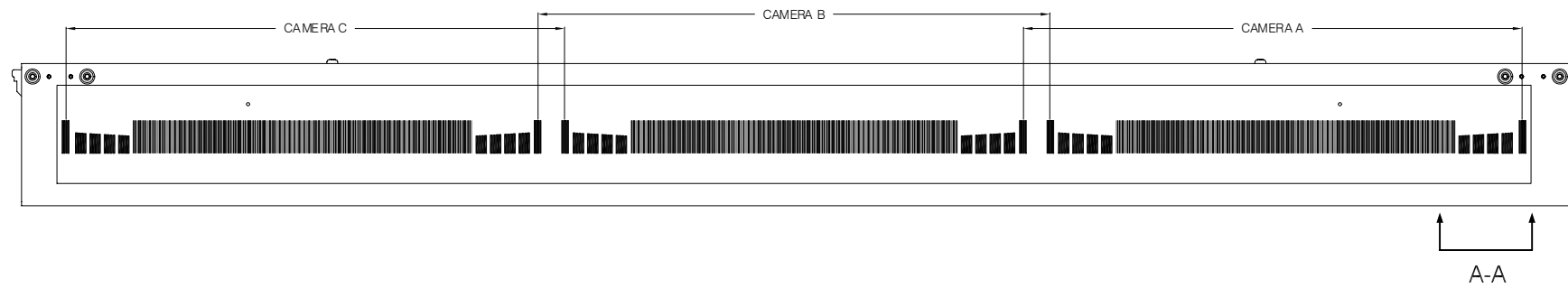

- Sub-pattern A: Scan-Width Patterns
- Sub-pattern B: Vertical Position Patterns
- Sub-pattern C: Focus Pattern (used for coarse Focus adjustment)

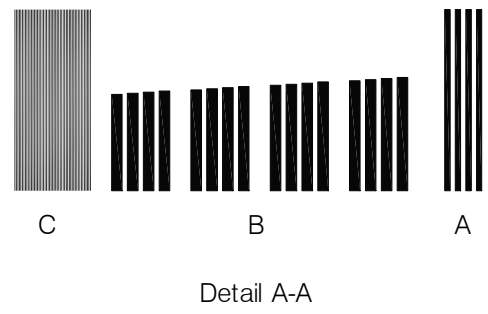

Fig. 4-14 Optical Adjustment Pattern, 3 Camera, 42"

5. Special Service Tools

Adjustment and Test Patterns:

Scanner Model:	COUGAR Sx 25 CHAMELEON Sx 25	CHROMA XL 42 CRYSTAL XL 42
Optical Adjustment Pattern, 25", 1 Cam. p/n 6779D105R01	×	
Optical Adjustment Pattern, 42", 3 Cam. p/n 6779D134R01		×
Focus Pattern, 25" p/n 6779D215R01	×	
Focus Pattern, 40" p/n 6779D216R01		×
SM Calibration Sheet, 25" p/n 6799D115	×	
SM Calibration Sheet, 42" p/n 6799D171		×

Special Tools:

Scanner Model:	COUGAR Sx 25 CHAMELEON Sx 25	CHROMA XL 42 CRYSTAL XL 42
Belt Tension Gauge p/n 6779D120	×	×
Adjustment Tools for Roller Sensor (2 pcs.) p/n 6779D133R01		×
Adjustment Tools for Top Position Sensor (2 pcs.) p/n 6779D246R01		×

For cleaning of the Glass Plate and the White Background Plate use:

- Ordinary window-cleaning detergent
- Soft lint-free cloth
- Microfibre Cleaning Cloth (as the cloth supplied with scanner)

For cleaning of the CCD use:

- A soft lint-free cloth and ethyl alcohol be careful not to scratch the glass.

6. Wiring Diagrams

Fig. 6-1 Sx 25 Primary Wiringpage 43
Fig. 6-2 Sx 25 Secondary Wiringpage 44
Fig. 6-3 XL 42 Primary Wiringpage 45
Fig. 6-4 XL 42 Secondary Wiringpage 46

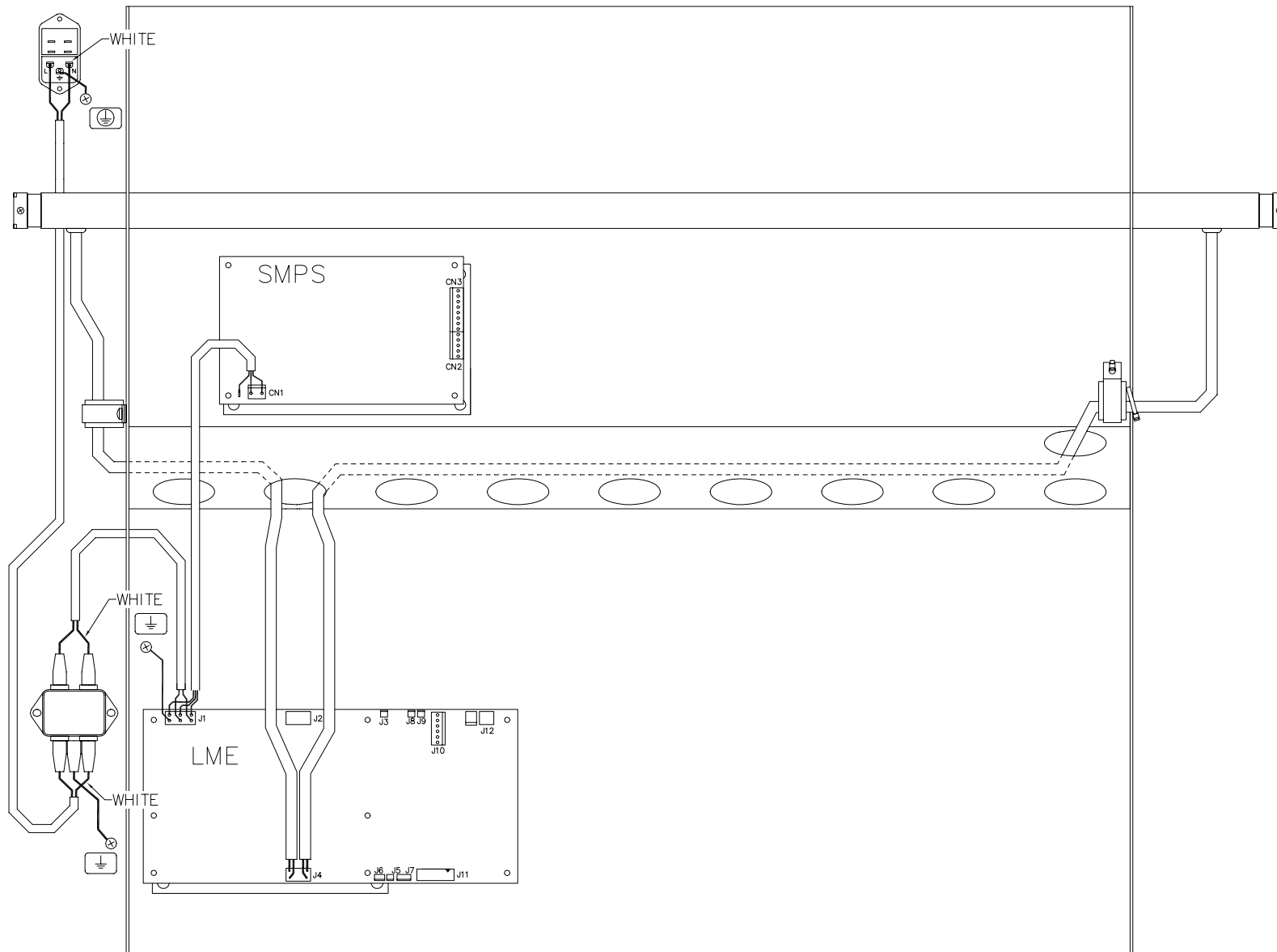

Fig. 6-1 Sx 25 Primary Wiring

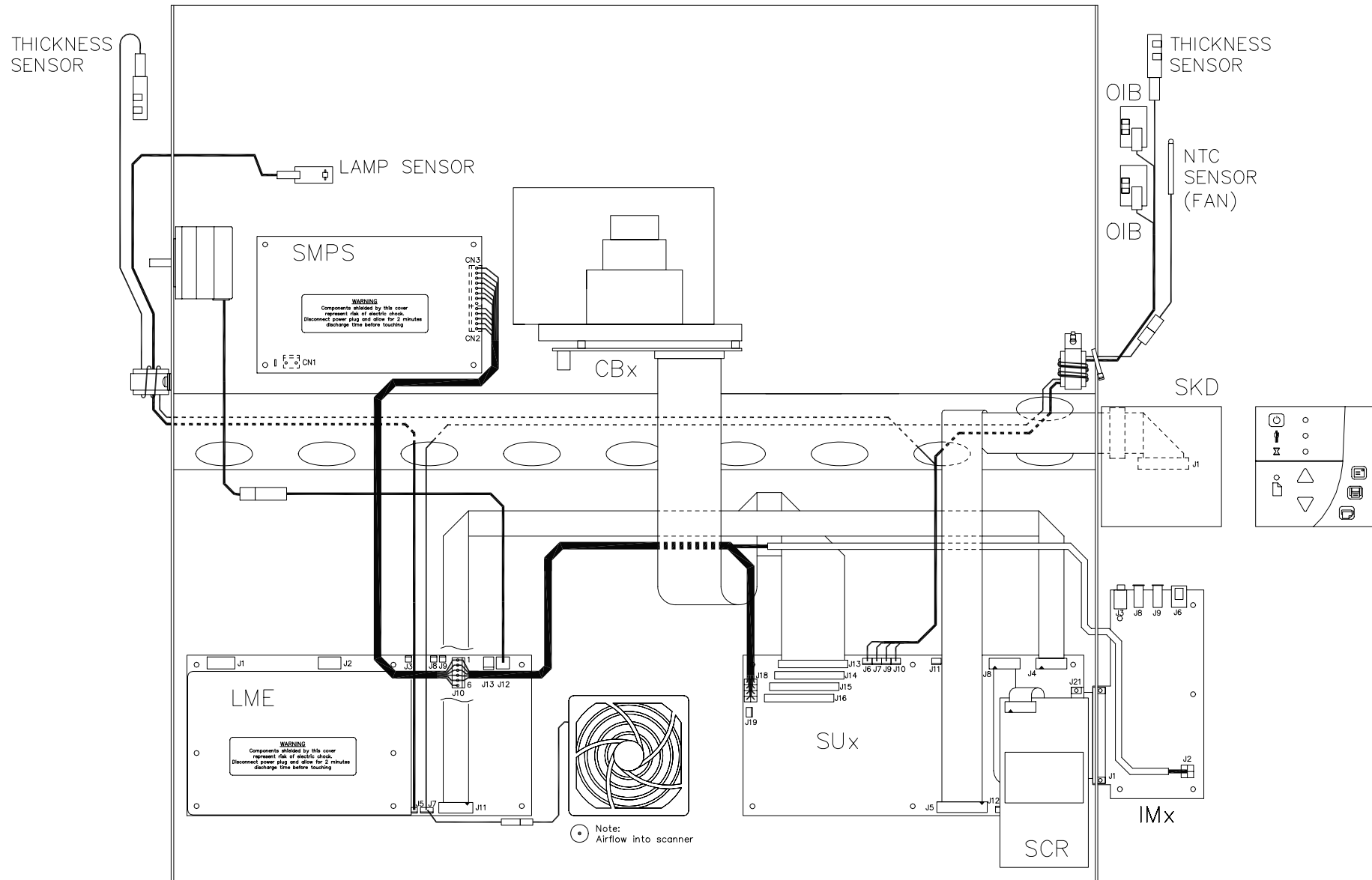

Fig. 6-2 Sx 25 Secondary Wiring

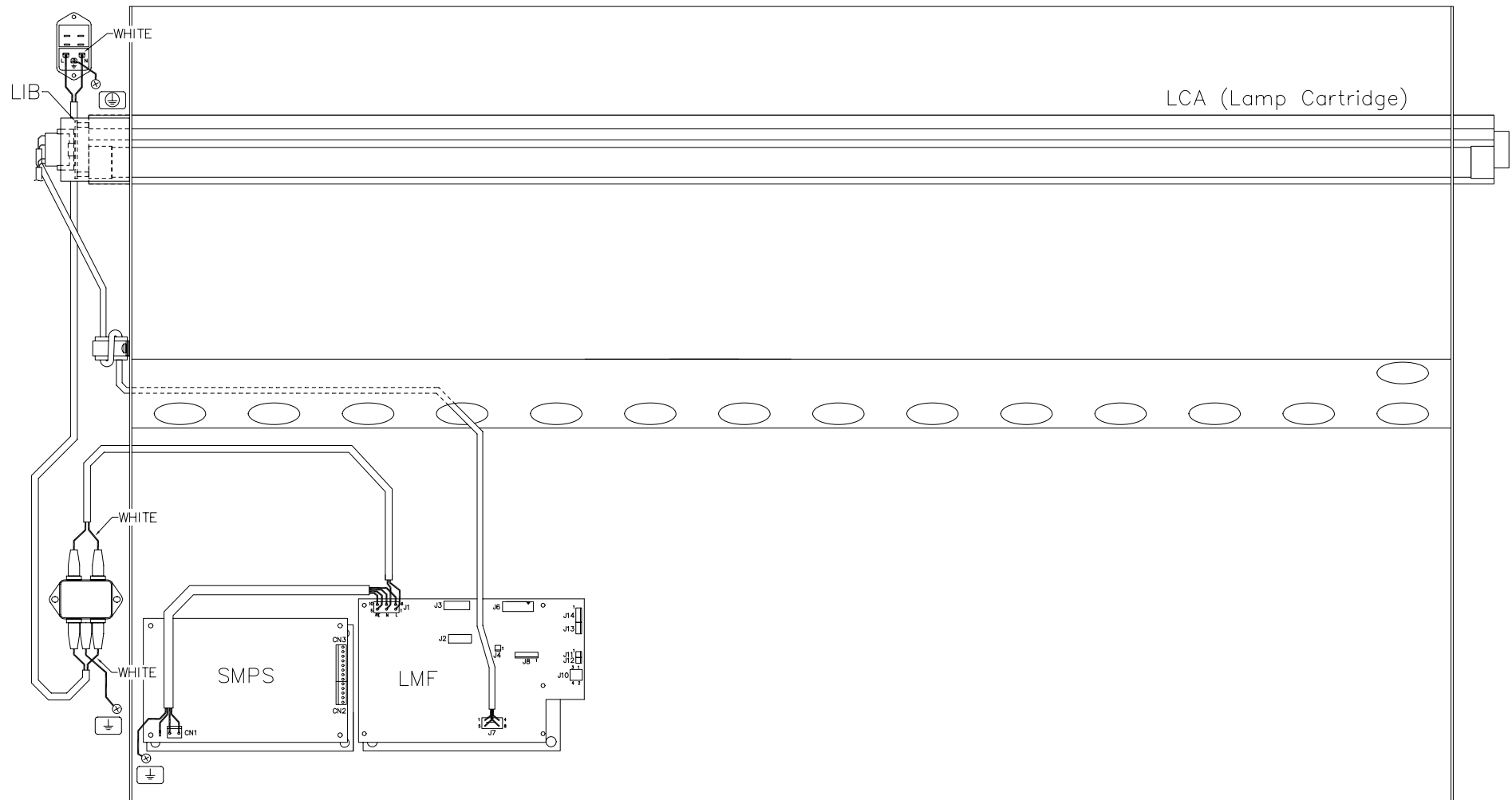

Fig. 6-3 XL 42 Primary Wiring

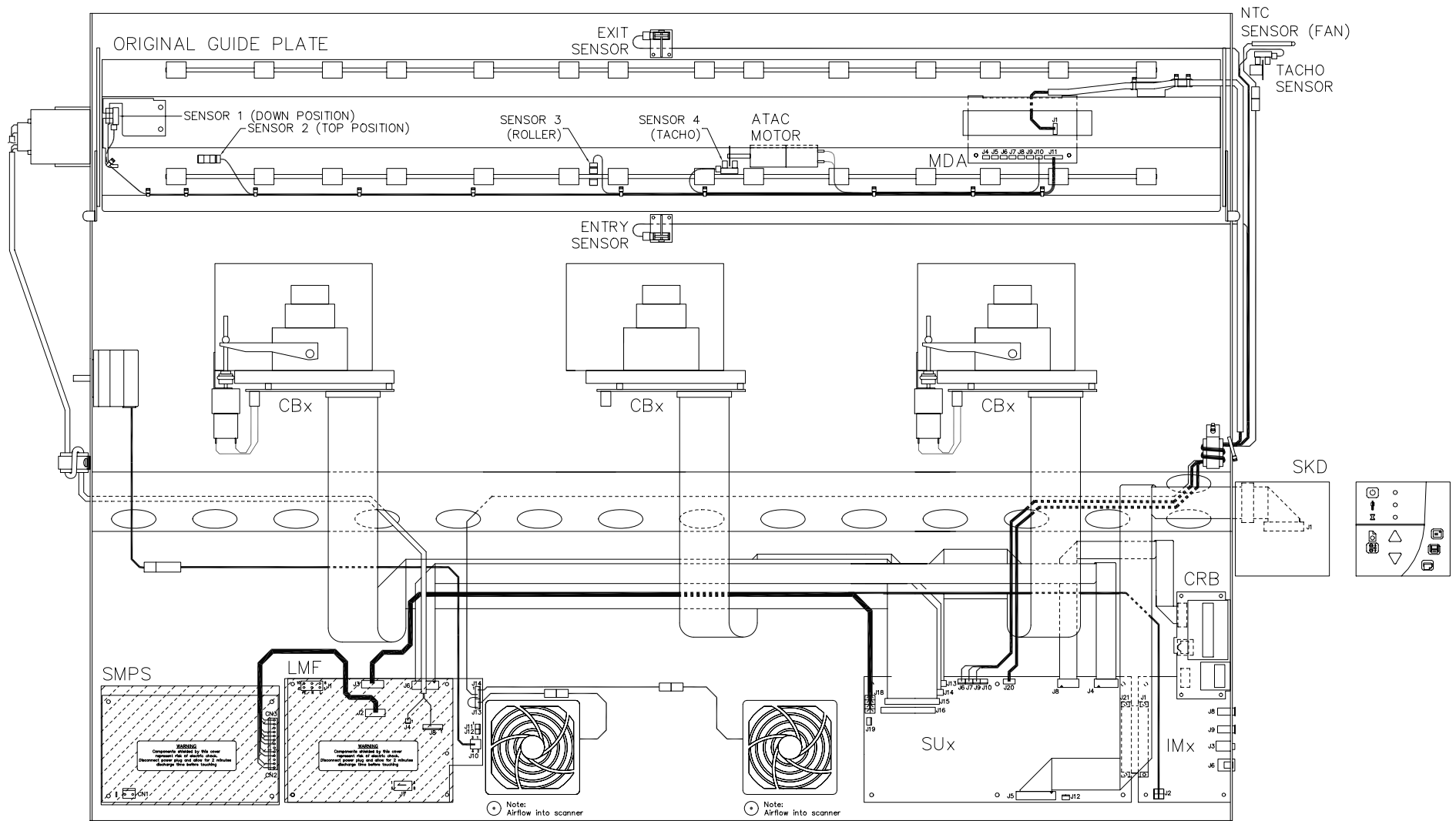

Fig. 6-4 XL 42 Secondary Wiring

TITLE: SPARE PARTS AND SERVICE ACCESSORIES
COUGAR 25, COUGAR 36, CHAMELEON 25,
CHAMELEON 36, CHAMELEON PREMIER 36
CHROMA Tx 40, CRYSTAL Tx 40
COUGAR Tx 36, CHAMELEON Tx 36, PREMIER Tx 36
MAGNUM XL 54
COUGAR Sx 25, CHAMELEON Sx 25
CHROMA XL 42, CRYSTAL XL 42
CHROMA HS 42, CRYSTAL HS 42

DOC. NO.: SOG/PLS/013

PREPARED BY: BN

AUTHORIZED: JR

DISTRIBUTION: Tegningsarkiv, Svendborg (1)
PT, Svendborg (1)
DD (1)

ISSUE REVISION: 1.8
DATE: 2006-03-28

This document is the property of Contex A/S. The data contained herein, in whole or in part, may not be duplicated, used or disclosed outside the Recipient for any purpose other than to conduct technical evaluation. This restriction does not limit the Recipients right to use information contained in the data if it is obtained from another source without restriction.

 Document Revision Record				DRR
REV.	DATE	CHANGED BY	PAGES AFFECTED	BRIEF DESCRIPTION OF CHANGE
1.0	010720	BN	All	Original Issue of Document
1.1	020501	BN	All	CHAMELEON PREMIER 36 CHROMA Tx 40, CRYSTAL Tx 40 added
1.2	030402	BN	All	COUGAR Tx 36, CHAMELEON Tx 36, PREMIER Tx 36 added
1.3	030619	BN	All	MAGNUM XL 54 added
1.4	031030	BN	All	Adj. Tools for Top Pos. Sensor and spring for Top Position Sensor Shutter added
1.5	040701	BN	All	Sx 25 and XL 42 models added. Packing spec (R01) added to p/n.
1.6	041122	BN	All	Drive Belts and pulleys, see note on p. 3 6702D818R01 -> 6702D716RA1 (Logo Badge) USB Cable for Sx 25 -> 6799D172R01 6702A259R01 -> 6702D259R01 (correction)
1.7	060322	LM	All	L. End Cover for Sx 25 -> 6702D262R01 (corr.) HS 42 models added 6702D262R01, End Cover (Left Hand Side) removed as 6702A204R01 can now be used by all scanners Gas Springs added
1.8	060328	LM	All	Column with recommended spare parts added Stepper Motor and Motor Pulley changed for HS 42 scanners

Table of Contents

1.	Introduction	3
2.	Recommended Spare Parts	4
3.	PCBs	5
4.	Electrical Parts	5
5.	Fuses	6
6.	Mechanical Parts.....	6
7.	Original Feed System	7
8.	Optical System.....	8
9.	Stand	9
10.	Receiving Table.....	9
11.	Scanner Accessories	9
12.	Service Accessories	9

1. Introduction

This document contains the Price List for Spare Parts and Service Accessories for the Wide Format Scanner models:

Model Name	Trade Name
GA67D	COUGAR 25
GB67D	COUGAR 36
GC67D	CHAMELEON 25
GD67D	CHAMELEON 36
GE67D	CHROMA Tx 40
GF67D	CRYSTAL Tx 40
GG67D	CHAMELEON PREMIER 36
GH67D	MAGNUM XL 54
GK67D	COUGAR Tx 36
GL67D	CHAMELEON Tx 36
GM67D	PREMIER Tx 36
GQ67D	COUGAR Sx 25
GR67D	CHAMELEON Sx 25
GN67D	CHROMA XL 42
GP67D	CRYSTAL XL 42
GS67D	CHROMA HS 42
GT67D	CRYSTAL HS 42

Note on Drive Belt:

The drive belt, motor pulley, feed roller pulleys, and intermediate belt wheel of the models listed below have been changed to belt and gears with a slightly different profile of tooth:

	Early Units	Current Units
Drive Belt	6763D209R01	6763D213R01
Motor Pulley	6763D202R01	6763D210R01
Feed Roller Pulley	6229X216 (not a spare part)	6763D212R01
Intermediate Belt Wheel	6763D103R01	6763D108R01

The changes have been implemented from the following serial numbers:

Model	Serial Number
CHROMA XL 42	GN67D48003X
CRYSTAL XL 42	GP67D48022L
COUGAR Sx 25	GQ67D4A002J
CHAMELEON Sx 25	GR67D4A012W

Due to the different profile of tooth, always replace with same type of drive belt and gears as originally used. Alternatively, for early unit, change drive belt and all gears to the types used in current models.

2. Recommended Spare Parts

The column "Recommended Spare Part" indicate parts which are considered as essential to carry out immediate repair and board level trouble shooting.

Description	Part Number	CRYSTAL HS 42	CHROMA HS 42	CRYSTAL XL42	CHROMA XL 42	CHAMELEON Sx 25	COUGAR Sx 25	MAGNUM XL 54	PREMIER Tx 36	CHAMELEON Tx 36	COUGAR Tx 36	CRYSTAL Tx 40	CHROMA Tx 40	CHAMELEON PREMIER 36	CHAMELEON 36	CHAMELEON 25	COUGAR 36	COUGAR 25	Recommended Spare Part
3. PCBs																			
LMEA, Lamp and Motor Driver Board	6741A001R01					x	x	x	x	x	x	x	x	x	x	x	x	x	x
LMFA, Lamp and Motor Driver Board	6834A001R01	x	x	x	x														x
OSBC, Optical Sensor Board	3132A003R01					x	x	x	x	x	x	x	x	x	x	x	x	x	
OIBA, Optical Interrupter Board	6336A001R01					x	x	x	x	x	x	x	x	x	x	x	x	x	
CBEA, Camera Board (with CCD-Sensor and Mounting Plate)	6735D001R01													x	x	x	x	x	
CBFA, Camera Board (with CCD-Sensor and Mounting Plate)	6737D001R01							x	x	x	x	x							x
CBIA, Camera Board (with CCD-Sensor and Mounting Plate)	6733E001R01					x	x												x
CBKA, Camera Board (with CCD-Sensor and Mounting Plate)	6742D001R01			x	x														x
CBMA, Camera Board (with CCD-Sensor and Mounting Plate)	6749D001R01	x	x																x
SUCA, Controller Board	6732D001RA1													x	x	x	x	x	
SUCB, Controller Board	6732D002RA1										x		x						x
SUCC, Controller Board	6732D003RA1									x		x							x
SUCD, Controller Board	6732D004RA1													x					x
SUCG, Controller Board	6732D007RA1								x										x
SUCH, Controller Board	6732D008RA1							x											x
SUCL, Controller Board	6732D009RA1			x		x													x
SUCM, Controller Board	6732D010RA1				x		x												x
SUFA, Controller Board	6748D001RA1	x																	x
SUFB, Controller Board	6748D002RA1		x																x
SKDA, Operator Panel	6733D001R01					x	x		x	x	x	x	x	x	x	x	x	x	
SKDF, Operator Panel	6733D006RA1							x											
SKDG, Operator Panel	6733D007RA1	x	x	x	x														
IMBA, Interface Module	6734D001R01																	x	x
IMBB, Interface Module	6734D002R01													x	x	x			x
IMDA, Interface Module	6740D001R01							x	x	x	x	x	x						x
IMEA, Interface Module, IEEE 1394 and USB 2.0	6835A001R01			x	x														x
IMFA, Interface Module, IEEE 1394 and USB 2.0	6743D001R01					x	x												x
IMGA, Interface Module	6841A001R01	x	x																x
MDAB, Elevation Motor Driver Board	6738D002R01							x											
MDAC, Elevation Motor Driver Board	6738D003R01	x	x	x	x														
SCR, Smart Card Reader, Assembly	6753A104R01					x	x	x	x	x	x	x	x	x	x	x	x	x	
CRBA, Smart Card Reader	6831A001R01			x	x														
CRBC, Card Reader Board	6831A003R01	x	x																
Switch Mode Power Supply, Adjusted	0080A058R01			x	x	x	x	x	x	x	x	x	x	x	x	x	x	x	x
CTX-Z07H, 68W SMPS, Triple Output	0080A064R01	x	x																x
4. Electrical Parts																			
Left Lamp Socket Assembly, 40"	6765D114R01								x	x	x	x	x	x	x			x	
Right Lamp Socket Assembly, 40"	6765D128R01								x	x	x	x	x	x	x			x	
Left Lamp Socket Assembly, 25"	6765D117R01																	x	x
Right Lamp Socket Assembly, 25"	6765D127R01																	x	x
Left Lamp Socket Assembly, 25"	6765D162R01					x	x												
Right Lamp Socket Assembly, 25"	6765D165R01					x	x												
Left Lamp Socket Assembly, 54"	6765D149R01							x											
Right Lamp Socket Assembly, 54"	6765D150R01							x											
Fluorescent Lamp, L36W/72-965, 1200 mm	0075D013R01								x	x	x	x	x	x	x			x	x
Fluorescent Lamp, L30W/72-965, 900 mm	0075D012R01					x	x											x	x
Fluorescent Lamp, L58W/72-965, 1500 mm	0075D015R01							x											x
LCAB, Lamp Cartridge, 42"	6840A002R01	x	x	x	x														x
Stepper Motor	0080C018R01	x	x	x	x	x	x	x	x	x	x	x	x	x	x	x	x	x	x
DC Gear Motor, 12V (Camera)	0080C022R01	x	x	x	x			x	x	x	x	x	x	x	x				

Description	Part Number	CRYSTAL HS 42	CHROMA HS 42	CRYSTAL XL42	CHROMA XL 42	CHAMELEON Sx 25	COUGAR Sx 25	MAGNUM XL 54	PREMIER Tx 36	CHAMELEON Tx 36	COUGAR Tx 36	CRYSTAL Tx 40	CHROMA Tx 40	CHAMELEON PREMIER 36	CHAMELEON 36	CHAMELEON 25	COUGAR 36	COUGAR 25	Recommended Spare Part
Drive Belt (O-Ring) for Gear Motor	6775D226R01							x	x	x	x	x	x	x	x				
O-Ring for Gear Motor (Camera)	0006T002R01	x	x	x	x														
Cooling Fan	0080C021R01							x	x	x	x	x	x	x	x	x	x	x	
Dust Filter for Cooling Fan	0080C023R01							x	x	x	x	x	x	x	x	x	x	x	
Cooling Fan, 92x92 mm	0080C032R01	x	x	x	x	x	x												
Filter kit, 92x92 (for 0080C032)	0080C031R01	x	x	x	x	x	x												
Elevation Motor, ATAC, 54"	6736D162R01							x											
Elevation Motor, ATAC, 42"	6736D173R01	x	x	x	x														
Optocoupler (Thickness Detector)	0075A024R01					x	x		x	x	x	x	x	x	x	x	x	x	
Optointerrupter (Original Guide Plate)	0075A050R01	x	x	x	x			x											
Spring for Top Position Sensor Shutter	6729A364R01	x	x	x	x			x											
Entry Paper Sensor, assy	6729D197R01	x	x	x	x														
Exit Paper Sensor, assy	6729D198R01	x	x	x	x														
Cable Ties	0002E009R01	x	x	x	x	x	x	x	x	x	x	x	x	x	x	x	x	x	
Magnet Catcher for SCR	6753A214R01					x	x	x	x	x	x	x	x	x	x	x	x	x	
Self-Adhesive Cable Clips, 9 mm	0002E026R01	x	x	x	x	x	x	x	x	x	x	x	x	x	x	x	x	x	
Insulation for Power Supply Board (LMx)	6736D201R01	x	x	x	x	x	x	x	x	x	x	x	x	x	x	x	x	x	
Insulation for SMPS	6738A201R01			x	x	x	x	x	x	x	x	x	x	x	x	x	x	x	
Insulation Foil for SMPS, 130x80	6730E201R01	x	x																
Power Entry Module	6738A122R01	x	x	x	x	x	x	x	x	x	x	x	x	x	x	x	x	x	
RFI-Filter	0077E038R01	x	x	x	x	x	x	x	x	x	x	x	x	x	x	x	x	x	
EMC Contact Spring for SKD	6702D238R01					x	x	x	x	x	x	x	x	x	x	x	x	x	
5. Fuses																			
<i>LMx</i>																			
T2.0AH, IEC127-2/5, UL R/C, 5x20 mm	0177A060202	x	x	x	x	x	x	x	x	x	x	x	x	x	x	x	x	x	
<i>SMPS (0080A058R01)</i>																			
F4A, IEC127-2/2, UL R/C, 5 x 20 mm	0177A030402	x	x	x	x	x	x	x	x	x	x	x	x	x	x	x	x	x	
6. Mechanical Parts																			
End Cover (Right Hand Side)	6702A203R01					x	x	x	x	x	x	x	x	x	x	x	x	x	
End Cover (Left Hand Side)	6702A204R01					x	x	x	x	x	x	x	x	x	x	x	x	x	
End Cover (Right Hand Side)	6702D258R01	x	x	x	x														
End Cover (Left Hand Side)	6702D259R01	x	x	x	x														
Lamp Cartridge Cover for 6702D258	6702D276R01	x	x	x	x														
Connector Cover for 6702D258	6702D277R01	x	x	x	x														
Top Cover with Front Profile, 36"	6702D707R01								x	x	x			x	x		x		
Top Cover with Front Profile, 25"	6702D706R01					x	x									x		x	
Top Cover with Front Profile, 40"	6702D102R01											x	x						
Top Cover with Front Profile, 42"	6702D122R01	x	x	x	x														
Top Cover with Front Profile, 54"	6702D115R01							x											
Top Profile (Lid), 40"	6702D804R01								x	x	x	x	x	x			x		
Top Profile (Lid), 25"	6702D810R01															x		x	
Top Profile (Lid), 54", Contex Badge included	6702D716RA1							x											
Top Profile (Lid), 42", Contex Badge included	6702D826RA1	x	x	x	x														
Top Profile (Lid), 25", Contex Badge included	6702D830RA1					x	x												
Model Streamer for COUGAR 36	6704D107R01																	x	
Model Streamer for CHAMELEON 25	6704D105R01																		x
Model Streamer for CHAMELEON 36	6704D103R01														x				
Model Streamer for CHAMELEON 25	6704D101R01															x			
Model Streamer for CHAMELEON PREMIER 36	6704D113R01													x					
Model Streamer for CHROMA Tx 40	6704D112R01												x						
Model Streamer for CRYSTAL Tx 40	6704D111R01											x							
Model Streamer for COUGAR Tx 36	6704D116R01										x								

Description	Part Number	CRYSTAL HS 42	CHROMA HS 42	CRYSTAL XL42	CHROMA XL 42	CHAMELEON Sx 25	COUGAR Sx 25	MAGNUM XL 54	PREMIER Tx 36	CHAMELEON Tx 36	COUGAR Tx 36	CRYSTAL Tx 40	CHROMA Tx 40	CHAMELEON PREMIER 36	CHAMELEON 36	CHAMELEON 25	COUGAR 36	COUGAR 25	Recommended Spare Part
Model Streamer for CHAMELEON Tx 36	6704D117R01									x									
Model Streamer for PREMIER Tx 36	6704D118R01								x										
Model Streamer for MAGNUM XL 54	6704D119R01							x											
Model Streamer for COUGAR Sx 25	6704D123R01						x												
Model Streamer for CHAMELEON Sx 25	6704D122R01					x													
Model Streamer for CHROMA XL 42	6704D851R01				x														
Model Streamer for CRYSTAL XL 42	6704D850R01			x															
Model Streamer for CHROMA HS 42	6704D862RA1		x																
Model Streamer for CRYSTAL HS 42	6704D863RA1	x																	
Streamer with Ruler, 36" (for Lid)	6704D827R01							x	x	x				x	x		x		
Streamer with Ruler, 42" (for Lid)	6704D846R01	x	x	x	x														
Streamer with Ruler, 25" (for Lid)	6704D826R01					x	x									x		x	
Streamer with Ruler, 40" (for Lid)	6704D828R01											x	x						
Streamer with Ruler, 54" (for Lid)	6704D835R01							x											
Friction Pad for Ruler (packed 10 pcs.)	6729A328R01					x	x	x	x	x	x	x	x	x	x	x	x	x	x
Bearing for Top Profile (Lid)	6702A246R01					x	x		x	x	x	x	x	x	x	x	x	x	x
Bearing for Top Profile (Lid)	6729D341R01	x	x	x	x			x											
Hinge with Pivot, Left	6702A116R01					x	x		x	x	x	x	x	x	x	x	x	x	x
Hinge with Pivot, Right	6702A117R01					x	x		x	x	x	x	x	x	x	x	x	x	x
Fittings for Top Profile, Left	6729D323R01	x	x	x	x			x											
Fittings for Top Profile, Right	6729D327R01	x	x	x	x			x											
7. Original Feed System																			
Original Guide Plate, complete, 40"	6729D120R01													x	x		x		
Original Guide Plate, complete, 25"	6729D122R01															x		x	
Original Guide Plate, complete, 25"	6729D196R01					x	x												
Original Guide Plate, complete, 40"	6729D137R01								x	x	x	x	x						
Original Guide Plate, complete, 42" (ATAC)	6729D179R01	x	x	x	x														
Original Guide Plate, complete, 54" (ATAC)	6729D163R01							x											
Gas Spring, 150N A40 (Guide Plate)	6705D264R01	x	x	x	x			x											
Gas Spring, 50N (ATAC) 2 pcs.	6729D414R01	x	x	x	x														
Gas Spring, 90N (ATAC) 2 pcs.	6729D364R01							x											
Slider for Media Thickness Adjustment	6729A123R01					x	x		x	x	x	x	x	x	x	x	x	x	x
Guide Bushings for Slider (packed, 10 pcs.)	6729A302R01					x	x		x	x	x	x	x	x	x	x	x	x	x
White Background Plate, 40", packed	6729D803R01								x	x	x	x	x	x	x		x		x
White Background Plate, 25", packed	6729D806R01					x	x									x		x	x
White Background Plate, 42", packed	6729D816R01	x	x	x	x														x
White Background Plate, 54", packed	6729D814R01							x											x
Actuator for Original Entry Sensor, 40"	6764D101R01								x	x	x	x	x	x	x		x		
Actuator for Original Entry Sensor, 25"	6764D103R01					x	x									x		x	
Actuator for Original Entry Sensor, 54"	6764D105R01							x											
Torsion Spring for Original Entry Sensor	6764A206R01					x	x	x	x	x	x	x	x	x	x	x	x	x	x
Actuator for Original Exit Sensor, 40"	6764D102R01								x	x	x	x	x	x	x		x		
Actuator for Original Exit Sensor, 25"	6764D104R01					x	x									x		x	
Actuator for Original Exit Sensor, 54"	6764D106R01							x											
Torsion Spring for Original Exit Sensor	6764A205R01					x	x	x	x	x	x	x	x	x	x	x	x	x	x
Bearing for Original Sensor Lever	6364B217R01					x	x	x	x	x	x	x	x	x	x	x	x	x	x
Shutter for Original Sensor	6364A102R01					x	x	x	x	x	x	x	x	x	x	x	x	x	x
Shaft with Feed-Rollers, 40"	6729D103R01								x	x	x	x	x	x		x			
Shaft with Feed-Rollers, 25"	6729D126R01					x	x									x		x	
Shaft with Feed-Rollers, 54"	6729D174R01							x											
Shaft with Feed-Rollers, 42"	6729D185R01	x	x	x	x														
Jointing Tongue	6329E220R01	x	x	x	x	x	x	x	x	x	x	x	x	x	x	x	x	x	x

Description	Part Number	CRYSTAL HS 42	CHROMA HS 42	CRYSTAL XL42	CHROMA XL 42	CHAMELEON Sx 25	COUGAR Sx 25	MAGNUM XL 54	PREMIER Tx 36	CHAMELEON Tx 36	COUGAR Tx 36	CRYSTAL Tx 40	CHROMA Tx 40	CHAMELEON PREMIER 36	CHAMELEON 36	CHAMELEON 25	COUGAR 36	COUGAR 25	Recommended Spare Part
Drive Belt for Feed-Rollers, HTD 564-3M	6363E223R01							x	x	x	x	x	x	x	x	x	x	x	
Drive Belt for Feed-Rollers, HTD 552-3M, <i>see note on p. 3</i>	6763D209R01			x	x	x													
Drive Belt for Feed-Rollers, STS-552-S3M-06	6763D213R01	x	x	x	x	x	x												
Feed Roller Pulley <i>see note on p. 3</i>	6763D212R01	x	x	x	x	x	x												
Intermediate Belt Wheel (toothed) <i>see note on p. 3</i>	6763D103R01			x	x	x	x	x	x	x	x	x	x	x	x	x	x	x	
Intermediate Belt Wheel (toothed)	6763D108R01	x	x	x	x	x	x												
Intermediate Belt Wheel (smooth)	6763D102R01							x	x	x	x	x	x	x	x	x	x	x	
Drive Belt Tightener	6763D101R01							x	x	x	x	x	x	x	x	x	x	x	
Drive Belt Tightener	6763D105R01	x	x	x	x	x	x												
Extension Spring	6775A252R01	x	x	x	x	x	x												
Motor Pulley <i>see note on p. 3</i>	6763D202R01			x	x	x	x	x	x	x	x	x	x	x	x	x	x	x	
Motor Pulley	6763D210R01	x	x	x	x	x	x												
Vibration Grommet for Feed Motor	6763D201R01	x	x	x	x	x	x	x	x	x	x	x	x	x	x	x	x	x	
Mounting Screw for for 6763D201	6763D204R01	x	x	x	x	x	x	x	x	x	x	x	x	x	x	x	x	x	
Shield over Entry Feed Roller Shaft, 40"	6702D704R01								x	x	x	x	x	x	x				
Shield over Entry Feed Roller Shaft; 25"	6702D109R01					x	x									x			x
Shield over Entry Feed Roller Shaft, 54"	6702D112R01							x											
Shield over Entry Feed Roller Shaft, 42"	6702D120R01	x	x	x	x														
Shield over Exit Feed Roller Shaft, 40"	6702D805R01								x	x	x	x	x	x					
Shield over Exit Feed Roller Shaft, 25"	6702D232R01					x	x									x			x
Shield over Exit Feed Roller Shaft, 54"	6702D244R01							x											
Shield over Exit Feed Roller Shaft, 42"	6702D268R01	x	x	x	x														
Fixing Screws for Roller Shields	6702A212R01	x	x	x	x	x	x	x	x	x	x	x	x	x	x	x	x	x	
Glass Plate, 40", packed	6729D105R01								x	x	x	x	x	x	x				x
Glass Plate, 25", packed	6729D127R01					x	x									x			x
Glass Plate, 54", packed	6729D172R01							x											x
Glass Plate, 42", packed	6729D187R01	x	x	x	x														x
Bearings for Glass Plate (packed, 10 pcs.)	6729A305R01					x	x		x	x	x	x	x	x	x	x	x	x	
Bearings for Glass Plate (packed, 10 pcs.)	6729D359R01	x	x	x	x			x											
Mounting Screws for Glass Plate (packed, 10 pcs.)	6729A332R01					x	x	x	x	x	x	x	x	x	x	x	x	x	
Magnetic Tape on glass plate (1300 x 8 mm)	6729A304R01	x	x	x	x	x	x	x	x	x	x	x	x	x	x	x	x	x	
Magnetic Tape on chassis (1300 x 10 mm)	6729A327R01	x	x	x	x	x	x	x	x	x	x	x	x	x	x	x	x	x	
Contact Pad for Glass Plate	6729A322R01	x	x	x	x	x	x	x	x	x	x	x	x	x	x	x	x	x	
Magnetic Paper Guides, packed	6799A121R01	x	x	x	x	x	x	x	x	x	x	x	x	x	x	x	x	x	
8. Optical System																			
Mirror Chassis, 40" (2 Cam)	6773D102R01								x	x	x			x	x			x	
Mirror Chassis, 25" (1 Cam)	6775D106R01					x	x									x			x
Mirror Chassis, 40" (3 Cam)	6773D104R01											x	x						
Mirror Chassis, 42" (3 Cam)	6773D125R01	x	x	x	x														
Mirror Chassis, 54" (4 Cam)	6773D123R01							x											
Lens Adapter for 6775D108/125	6775D223R01								x	x	x			x	x	x	x	x	
Focus Lock Ring for 6775D108	6775D224R01														x	x	x	x	
Lens Adapter for 6775D115	6775D234R01							x				x	x						
Lens with filter, Ace FF60	6775D108R01					x	x							x	x	x	x	x	
Lens with filter, Ace FF61B	6775D115R01	x	x	x	x			x				x	x						
Lens with filter, Ace FF84AB	6775D125R01								x	x	x								
Stitching Wire, dia. = 0.3 mm (black)	6375E801R01	x	x	x	x			x	x	x	x	x	x	x	x	x	x	x	
Leaf Spring for Stitching Wire	6729A205R01	x	x	x	x			x	x	x	x	x	x	x	x	x	x	x	

Description	Part Number	CRYSTAL HS 42	CHROMA HS 42	CRYSTAL XL42	CHROMA XL 42	CHAMELEON Sx 25	COUGAR Sx 25	MAGNUM XL 54	PREMIER Tx 36	CHAMELEON Tx 36	COUGAR Tx 36	CRYSTAL Tx 40	CHROMA Tx 40	CHAMELEON PREMIER 36	CHAMELEON 36	CHAMELEON 25	COUGAR 36	COUGAR 25	Recommended Spare Part
Tension Spring for Vertical Alignment Arm	6775A264R01							x	x	x	x	x	x	x	x	x	x		
Tension Spring for Cameral Alignment	6775A252R01	x	x	x	x			x	x	x	x	x	x	x	x	x	x	x	
Tension Spring for Camera Base Plate	6775A253R01	x	x	x	x	x	x	x	x	x	x	x	x	x	x	x	x	x	
9. Stand																			
Base, 40"	2205D702R01									x	x	x	x	x	x		x		
Base, 25"	2205D706R01																		x
Top Bar, 40"	2205D703R01	x	x	x	x				x	x	x	x	x	x					
Top Bar, 25"	2205D707R01					x	x												
Left Foot, small	2205D716R01	x	x	x	x	x	x												
Right Foot, small	2205D717R01	x	x	x	x	x	x												
Connect Tube, 25"	2205D719R01					x	x												
Connect Tube, 40"	2205D718R01	x	x	x	x														
Left Foot	2205D710R01							x											
Right Foot	2205D711R01							x											
Connect Tube, 54"	2205D712R01							x											
Top Bar, 54"	2205D713R01							x											
Left Leg	2205A716R01	x	x	x	x	x	x	x	x	x	x	x	x	x	x	x	x	x	
Right Leg	2205A717R01	x	x	x	x	x	x	x	x	x	x	x	x	x	x	x	x	x	
Collection Basket, Complete, 40"	2205D705R01	x	x	x	x				x	x	x	x	x	x	x		x		
Collection Basket, Complete, 25"	2205D709R01					x	x									x		x	
Collection Basket, Complete, 54"	2205D128R01							x											
Castor w/o Brake for Scanner Bogie	2205A109R01	x	x	x	x	x	x	x	x	x	x	x	x	x	x	x	x	x	
Castor with Brake for Scanner Bogie	2205A110R01	x	x	x	x	x	x	x	x	x	x	x	x	x	x	x	x	x	
Fixing Screw for Scanner	2205A211R01	x	x	x	x	x	x	x	x	x	x	x	x	x	x	x	x	x	
10. Receiving Table																			
Height Adjustment Screw	2205A137R01	x	x	x	x				x	x	x	x	x	x	x		x		
11. Scanner Accessories																			
AT-to-SCSI Host Adapter for PCI Bus	0090B019R01							x	x	x	x	x						x	x
SCSI Cable, HD50/HD50, 3 m	0090B044R01							x	x	x	x	x							x
USB Cable, 3 m	0090B051R01													x	x	x	x	x	
USB Cable with Ferrite	6799D172R01	x	x	x	x	x	x												
IEEE 1394 Controller Board (Fire Wire)	0090B056R01	x	x	x	x	x	x	x	x	x	x	x							
IEEE 1394 Cable with Ferrite	6799D140R01	x	x	x	x	x	x	x	x	x	x	x							
12. Service Accessories																			
Optical Adjustment Pattern, 40", 2 Cam.	6779D107R01													x	x		x		x
Optical Adjustment Pattern, 25", 1 Cam.	6779D105R01					x	x									x			x
Optical Adjustment Pattern, 40", 3 Cam.	6779D102R01											x	x						
Optical Adjustment Pattern, 42", 3 Cam.	6779D134R01	x	x	x	x														
Optical Adjustment Pattern, 36", 2 Cam.	6779D127R01							x	x	x									
Optical Adjustment Pattern, 54", 4 Cam.	6779D130R01							x											
Focus Pattern, 40"	6779D216R01	x	x	x	x			x	x	x	x	x	x	x	x		x		x
Focus Pattern, 25"	6779D215R01					x	x									x			x
Focus Pattern, 54"	6779D228R01							x											
SM Calibration Sheet, 40", packed	6799D116								x	x	x	x	x	x	x		x		x
SM Calibration Sheet, 42", packed	6799D171	x	x	x	x														
SM Calibration Sheet, 25", packed	6799D115					x	x									x			x
SM Calibration Sheet, 54", packed	6799D165							x											
Adjustment Tools for Roller Sensor (2 pcs)	6779D133R01	x	x	x	x			x											
Adjustment Tools for Top Position Sensor (2 pcs)	6779D246R01	x	x	x	x			x											

DATE
031015

INIT.
LM

SUBJECT: Camera Motor Drive Belt
APPLY TO: See below

PAGE
1 OF 1

DESCRIPTION:

It has turned out that the drive belt on the camera motor on scanners produced until medio October 2003 may crack and eventually break causing the camera alignment to fail. A new drive belt has been introduced and implemented in production from the following serial numbers:

Model	Name	Serial Number	Belts
GB67D	COUGAR 36	*	1
GD67D	CHAMELEON 36	*	1
GE67D	CHROMA Tx 40	GE67D3A002	2
GF67D	CRYSTAL Tx 40	GF67D3A008	2
GG67D	CHAMELEON PREMIER 36	*	1
GH67D	MAGNUM XL 54	GH67D3A006	3
GK67D	COUGAR Tx 36	GK67D3A012	1
GL67D	CHAMELEON Tx 36	GL67D3A016	1
GM67D	PREMIER Tx 36	GM67D3A007	1

* all produced with old type

RECOMMENDED ACTION:

It is recommended to change drive belt on scanners with serial numbers lower than the ones listed above at the next service call.

New drive belts can be ordered from Contex free of charge under the part number 6775D226. Any drive belts which you may have on stock should be discarded.

Please order all the belts you need at the same time. Refer to the table above for the number of belts to order per scanners in the field.

DATE
040506

INIT.
LM

SUBJECT: Lamp Driver Adjustment
APPLY TO: All 6G scanners covered by FSG/TSM/001

PAGE
1 OF 2

DESCRIPTION:

Because of higher demands to the light level in later scanners, the general specification for the lamp driver adjustment has been changed as described on page 2.

The former specification where the voltage on TP7 from time to time was readjusted to a certain level gradually lowered the light level in the scanner. This is because the voltage on TP7 increases with lamp ageing to compensate for drop in lamp efficiency. Or in other words, the older the lamp, the higher the voltage on TP7 for the same light level. The voltage on TP7 will therefore slowly increase over time and if readjusted the light level is lowered.

To ensure a constant predefined light level in the scanners throughout the lifetime of the lamp, the lamp driver should therefore **ONLY** be adjusted when the lamp is new. In this way the light level is kept at a known predefined level.

This means that the lamp driver is **ONLY** adjusted when changing either:

- the Lamp
- the Lamp Driver Board, LME
- the Lamp Sensor Board, OSB

and in order to do so the lamp **MUST** be new.

It is generally recommended always to replace the lamp before replacing the Lamp Driver Board

The following label will be placed on the LME board of new scanners adjusted after the new procedure:



RECOMMENDED ACTION:

It is recommended to change the lamp after 4.000 hours corresponding to every second year if the scanner is switched on for 8 hours per day.

At regular service calls check the lamp-on time (SCANtest 6, Test 1). When higher than 4.000 hours replace the lamp.

DATE
040506

INIT.
LM

SUBJECT: Lamp Driver Adjustment

APPLY TO: All 6G scanners covered by FSG/TSM/001

PAGE
2 OF 2

Lamp Driver Adjustment: (refer to the LME component layout below)

1. Make sure that the lamp is new. If not it must be replaced
2. Remove the front cover of the scanner
3. Switch on the scanner
4. Wait for the lamp to switch on for the *second* time (after approx. 30 seconds)
5. Turn P2 CW until LED3 switches ON and then slowly CCW until LED3 switches OFF *
6. Leave the scanner on for 1 minute
7. Turn P2 CW until LED3 switches ON and then slowly CCW until LED3 switches OFF *
8. Replace the front cover
9. Reset the lamp counter:
 - Start SCANtest 6
 - Select Test 1 (Scanner Information)
 - Press the button “Reset Lamp Counter”
 - Type the password “xetnoc” and press “Reset Lamp Counter”
10. Calibrate the scanner

* On early LME boards the LED’s are missing. In this case connect a voltmeter between TP7 and GND and adjust to -300mV. Note that the voltage will change slightly after adjustment, but this is normal and does not call for continued re-adjustments.

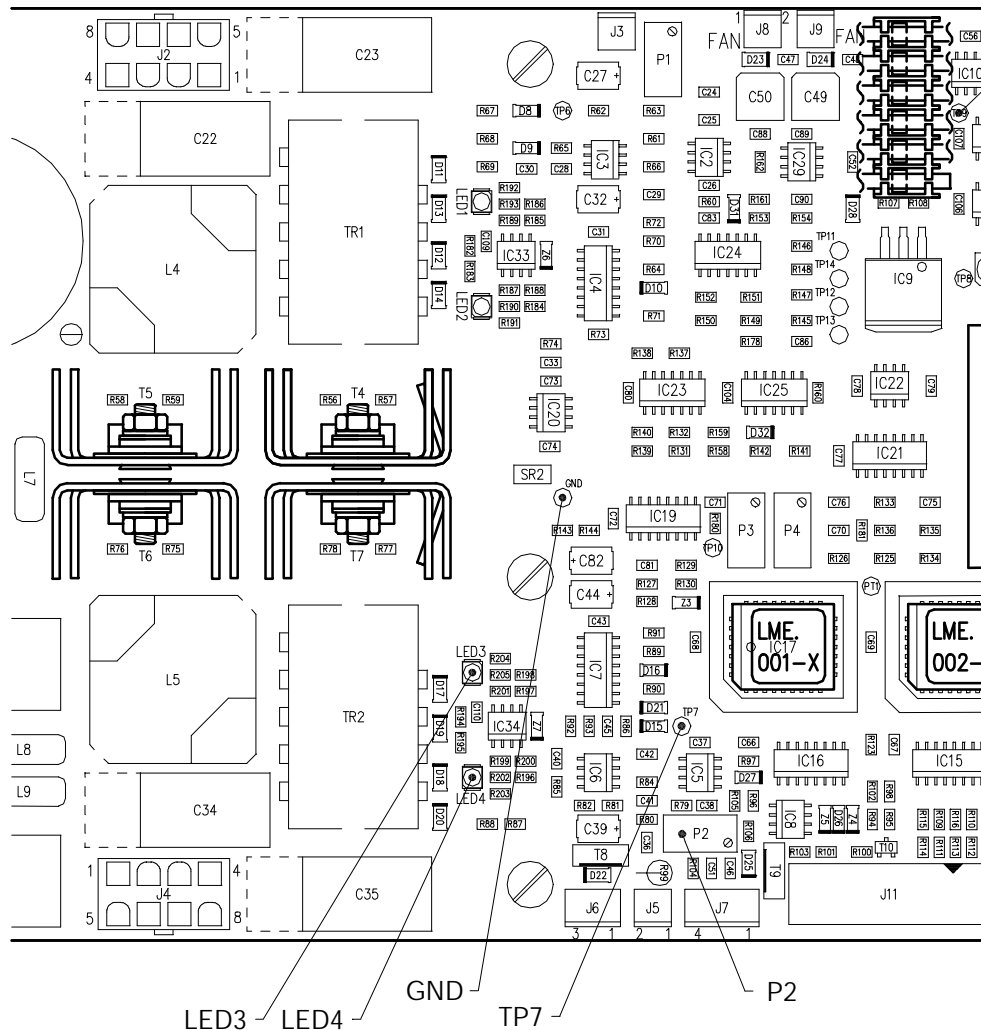

DATE
050223

INIT.
LM

SUBJECT: ATAC Calibration
APPLY TO: XL 42 Scanners

PAGE
1 OF 1

DESCRIPTION:

From firmware release 50 (Build 799) and SCANtest 6 version 7.0.1 a new test has been added:

Test 30: Calibrate ATAC

This test sets the current level at which the ATAC will stop if something is preventing it from moving. The first scanners shipped had a predefined current level but with this new test the ATAC system adapts to the actual friction level of the system.

To calibrate the ATAC simply run Test 30. If the calibration fail this is most likely because the tacho sensor is not functioning. In this case correct as described below.

RECOMMENDED ACTION:

In case the ATAC calibration fails:

1. Move Original Guide Plate to upper position
2. Open Original Guide Plate
3. Remove Ruler and the four fixing screws located behind the Ruler
4. Close Original Guide Plate
5. Open Top Cover
6. Bend the Tacho Sensor Bracket towards the Tacho Disc in order to permanently change the position of the opto interrupter, see image below
7. Run Test 30 to see that the calibration now succeeds. If not, bend the bracket further and check again.
8. Assemble in reverse order

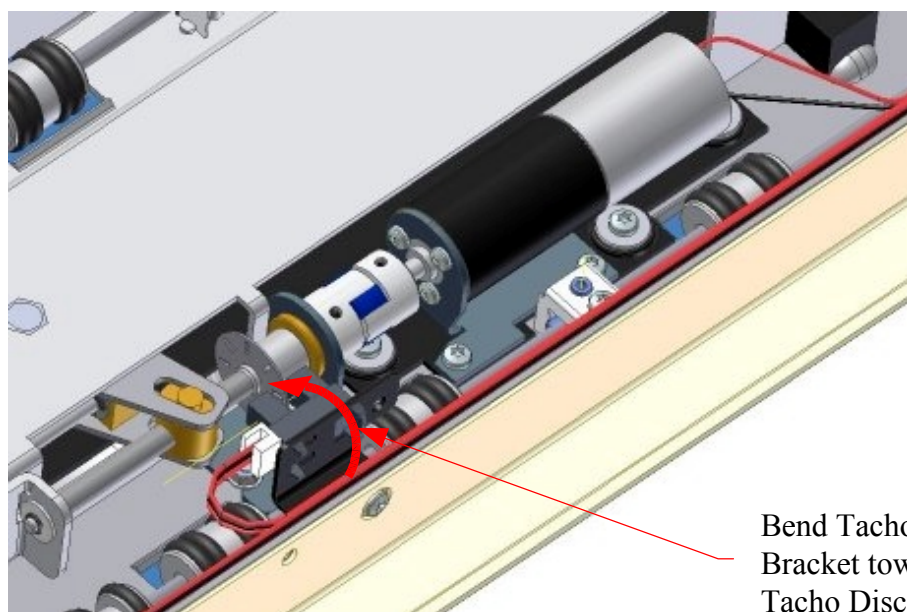

Bend Tacho Sensor Bracket towards Tacho Disc

DATE
060103INIT.
LM

SUBJECT: Camera Spare Part Board 6735D001R01

APPLY TO: GA67D, GB67D, GC67D, GD67D, GG67D

PAGE
1 OF 1**DESCRIPTION:**

Due to circumstances outside the control of Contex the CBEA board used in the below listed scanners can no longer be produced:

- GA67D (COUGAR 25)
- GB67D (COUGAR 36)
- GC67D (CHAMELEON 25)
- GD67D (CHAMELEON 36)
- GG67D (CHAMELEON PREMIER 36)

Instead it has been replaced by the CBIA board which uses a different CCD chip. Unfortunately the new camera board requires a new firmware and in case of 2 camera scanners both camera boards need to be replaced.

Because of this Contex has changed the CBEA spare part 6735D001R01 to include the following:

- 2 pcs. CBIA Camera Boards
- Firmware CD
- Upgrade Note

This does in no way influence on the performance of the scanner.

COMMENTS:

Firmware Release 61 Build 1172 or newer supports both CBEA and CBIA camera boards. As the scanner is not able to determine which board is installed, switch 6 on the SCSI ID switch must be set to ON when the new CBIA board is installed.

IMPORTANT: *If upgrading to firmware Release 61 Build 1172 or newer on scanners with the old CBEA camera board, make sure that the SCSI ID is not set to "0" (this also apply to non SCSI scanners). If this is the case and the other switches are also OFF (i.e. all switches are OFF) this will make the scanner believe that switch 6 is ON (even though it is not) resulting in camera board errors.*